



*Model FCT/G-4RR Food Court Table, galvanized frames,
4 ft. long, surface mount, with red thermo-plastic coated
R-Type perforated steel top and seats.*

- **Seats four with small surface footprint**
- **Wheelchair or stroller access at both ends.**
- **All welded frames are fabricated from 2-3/8" diameter steel pipe.**
- **Frames are hot dip galvanized after fabrication for superior corrosion resistance.**
- **Thermo-plastic Coating heat fused to Perforated Steel Top and Seats for durability**
- **Thermo-plastic Coating formulated with U.V. stabilizers for ultraviolet protection**

AVAILABLE OPTIONS

- Powder coat frame finish in choice of colors.**
- Choice of colors of thermo-plastic coating.**
- Cover caps for frame posts.**

SPECIFICATIONS:

- **Model FCT** frames are one-piece welded construction, fabricated from 2.375" O.D. (2-3/8" O.D.) 11 ga. wall steel pipe to meet 2" nominal steel pipe size specifications, with heavy gauge steel die-formed angles for attaching/supporting seats and top. The two frame structures bolt together under the table top. Welded-on mounting plates with 9/16" dia. holes allow table to be permanently anchored to a hard surface.
- Surface mount (bolt down) installation provides a secure location. Set of (4) screw anchors for concrete surfaces are included.
- Model FCT-4 table is 4 ft. long and seats four people with walk in access to seats.
- Overall footprint of this table is 48" long x 58" wide.
- Nominal table height 29-1/2". Nominal seat height is 16-1/2".
- All fasteners are provided for assembly.
- The open span frame design of Model FCT Food Court Table creates a clear area under and around the table for easy clean up.
- **Standard:** All steel frame components are hot-dip galvanized after fabrication to ASTM-A123 to maintain an average zinc coating of 2.0 oz. per sq. ft. of surface area (indicated by "/G" in model no., e.g.. FCT/G-4RW.)
- **R-Type** table top and seats are each one-piece welded construction, fabricated from a 14 ga. perforated steel surface with 9/16" dia. holes in a 13/16" center to center in-line pattern and 2" formed vertical edges on all sides and reinforced by a strap and die-formed angle substructure.
- **Standard:** All steel surfaces of the top and seats are covered with a thermo-plastic coating in a Brown color (indicated by "RW" in model no., e.g. FCT/G-4RW). The UV-stabilized thermo-plastic coating is applied in a multi step process of material preparation and finish application designed to permanently heat fuse and bond the finish to the steel. The thermo-plastic polyethylene finish is impact resistant, does not support mold or mildew, and the textured matte surface is less susceptible to marring and scuffing.
- **Optional:** Color choices of thermo-plastic coated steel components. For optional colors choices see Specification Bulletin #SPC-CO-001.
- **Optional:** Color choices of powder coated steel frame components. For optional colors choices see Specification Bulletin #SPC-CO-001.
- **Optional:** 2-part aluminum cover caps for frame post anchor plates. Order (4) #CC-1 cover caps. Standard aluminum finish will coordinate with hot dip galvanized frame finish. Powder coat finish available to match optional frame finish colors.

RJ Thomas Mfg. Co., Inc.

PO Box 946 • Cherokee, IA 51012-0946 • PH: 712-225-5115 • 800-762-5002 • FAX: 712-225-5796
E-mail: pilotrock@rjthomas.com • Web Site: <http://www.pilotrock.com>

© 2019 RJ Thomas Mfg. Co., Inc. PILOT ROCK® Park Products is a registered trademark of RJ Thomas Mfg. Co., Inc.

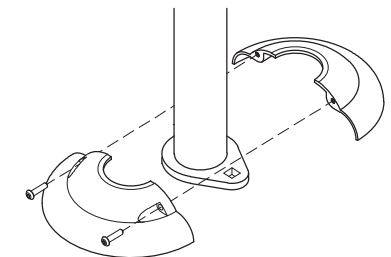
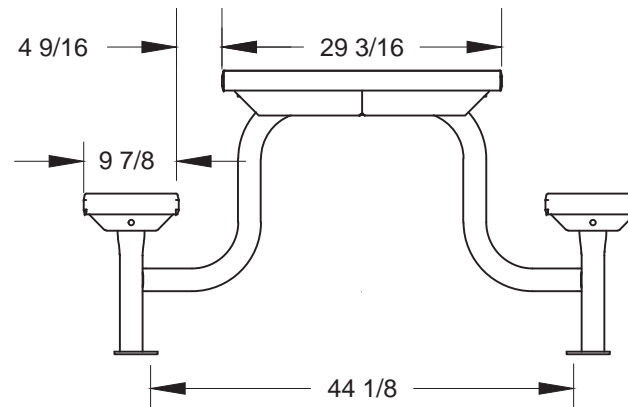
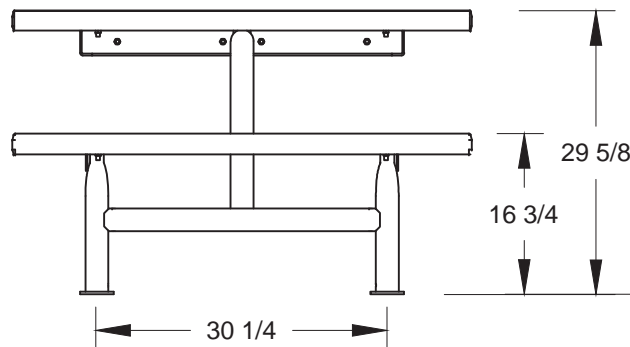
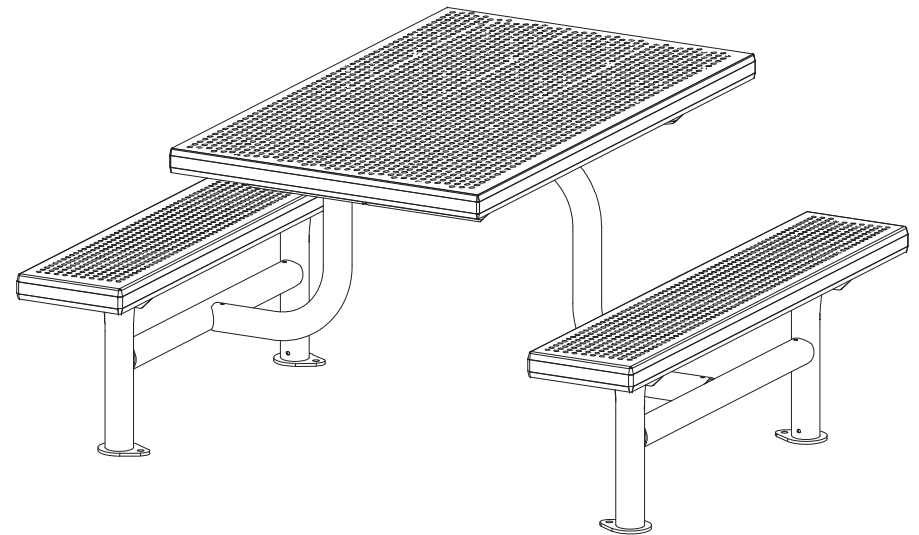
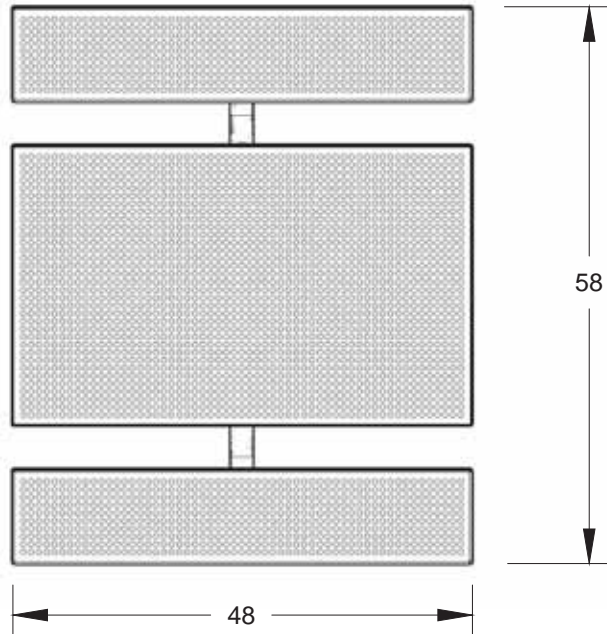

MODEL CC-1
SURFACE INSTALLATION
TWO-PART ALUMINUM COVER CAP

ALL DIMENSIONS IN INCHES

RJThomas Mfg. Co., Inc.
P.O. Box 946 • Cherokee, IA 51012-0946

DRAWN BY
JGJ

TITLE **MODEL FCT 4 FOOT FOOD COURT TABLE WITH THERMO-PLASTIC COATED R-TYPE PERFORATED STEEL TOP AND SEATS**

DATE 10-16-17

DWG. NO. **AI-2085**