



Model UT/G-12AL/SA 12 Ft. Wheelchair Accessible Heavy Duty Portable Rectangular Table with Hot Dip Galvanized Frame and Aluminum top and seats. Table provides access for two wheelchairs.

- **ADA compliant access for two wheelchairs**
- **Nontip, nontrip, walk-through design**
- **All welded end frames are fabricated from 1.66" diameter steel pipe**
- **Die-formed center channel and diagonal braces align and strengthen entire table**
- **Frames are hot dip galvanized after fabrication for superior corrosion resistance**
- **Seats and Top are Aluminum with a clear anodized maintenance free finish**
- **Limited lifetime warranty on frames**

AVAILABLE OPTIONS

10' or 12' length

Powder Coat Finish in choice of colors for steel frame components

Powder Coat Finish in choice of colors for aluminum top and seats

SPECIFICATIONS:

- **UT Series** end frames are one-piece welded construction, fabricated from 1.660" O.D. (1-5/8" O.D.) steel pipe to meet 1-1/4" nominal pipe size specifications with 2" x 2" x 1/8" die formed steel angle for attaching the seats and tops.
- Table frame design incorporates nontip, nontrip, walk-through design features.
- Table provides two wheelchair spaces created by attaching one short seat and one long seat to end frames diagonally opposite each other. Short seats are supported by a 10 ga. steel plate bracket. Gap between seats create a ADA recommended space of 30" wide, 19" deep, and 27" from ground to bottom of table top for knee space, and minimum 9" above ground extending a total of 24" deep for toe space. Indicated by "/SA" at end of model no., e.g. UT/G-10AL/SA.
- **Model UT/G-10AL/SA** is a nominal 10 ft. long with three frames, one 21-3/4" long seat and one 68-1/4" long seat on each side.
- **Model UT/G-12AL/SA** is a nominal 12 ft. long with three frames, one 21-3/4" long seat and one 82-5/8" long seat on each side.
- Nominal table height, 30". Nominal seat height, 18".
- Frames are supported by diagonal braces of 1-5/16" O.D. x 14 ga. wall steel pipe that connect to a die-formed steel channel designed to align and provide attachment to the table top.
- **Standard:** All steel frame components are hot-dip galvanized after fabrication to ASTM-A123 to maintain an average zinc coating of 2.0 oz. per sq. ft. of surface area (indicated by "/G" in model no., e.g. UT/G-10AL/SA).
- All fasteners are provided for assembly.
- Aluminum is extruded 6063-T6 aluminum alloy in planks with dimensions equivalent to that of 2" x 10" nominal sized lumber. The plank design is 1-3/4" x 9-5/8" with four structural reinforcement ribs for greater rigidity. Aluminum planks are provided with a clear anodized finish as per anodizing specification 204 R1. Aluminum clips to fasten planks to frames are included.
- Channel end caps are of extruded 6063-T6 aluminum alloy provided with a clear anodized finish as per anodizing specification 204 R1. End caps are press fitted over ends of aluminum planks and mechanically fastened in place at the factory.
- Table tops are assembled into single units at the factory with one-piece end caps across each end.
- **Optional:** All steel frame components have powder coat finish. See Specification Bulletin #SPC-CO-001.
- **Optional:** Aluminum top and seat planks and end caps have powder coat finish. For color choices see Specification Bulletin #SPC-CO-001.

RJ Thomas Mfg. Co., Inc.

PO Box 946 • Cherokee, IA 51012-0946 • PH: 712-225-5115 • 800-762-5002 • FAX: 712-225-5796
E-mail: pilotrock@rjthomas.com • Web Site: <http://www.pilotrock.com>

© 2017 RJ Thomas Mfg. Co., Inc. PILOT ROCK® Park Products is a registered trademark of RJ Thomas Mfg. Co., Inc.

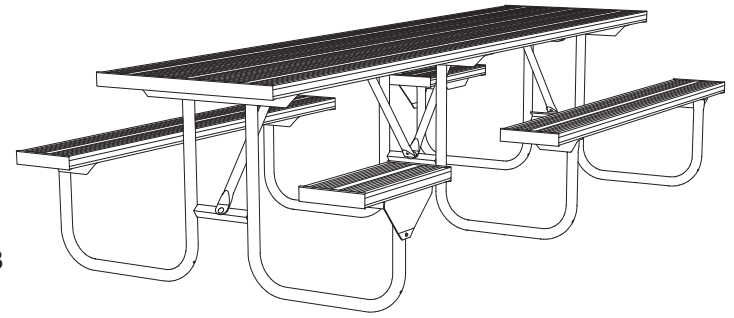
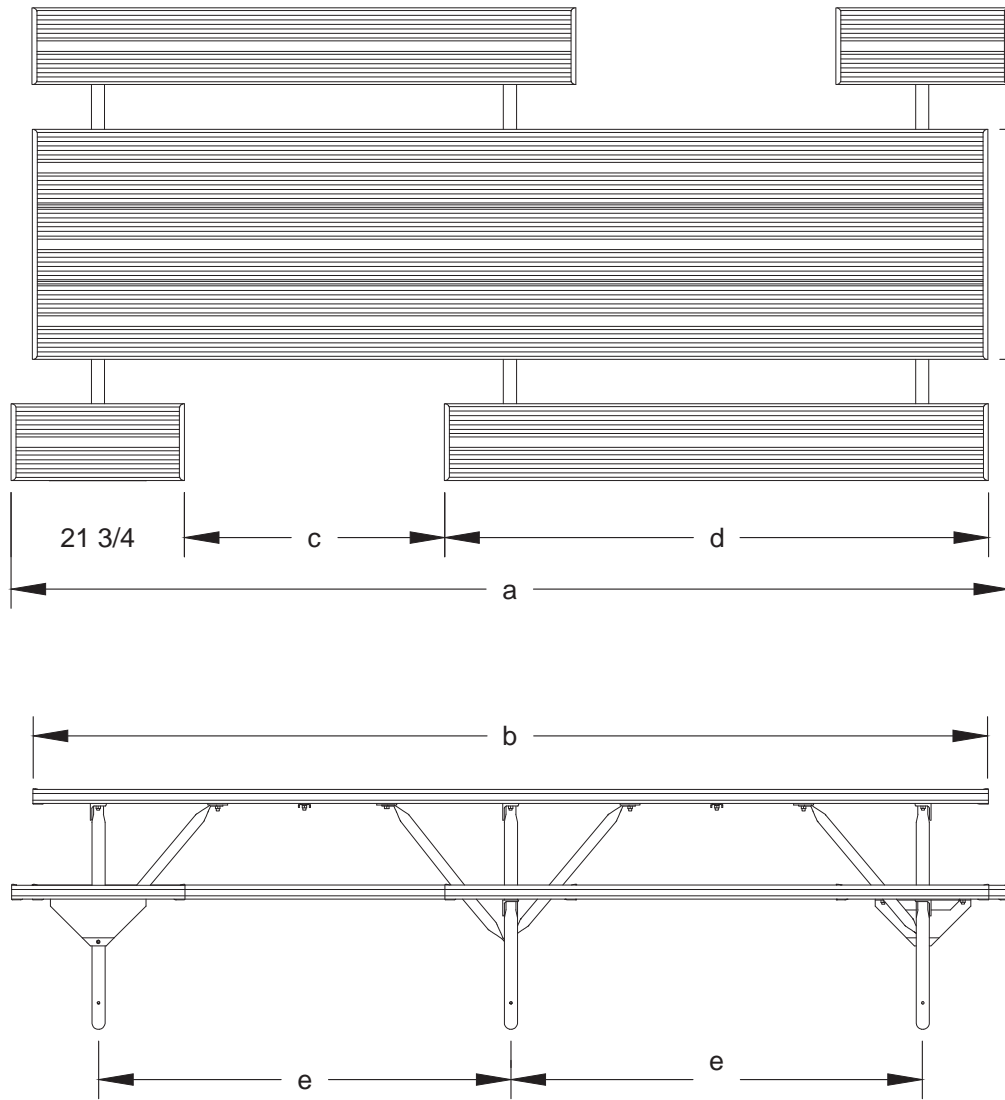

MODEL NUMBER	DIMENSION				
	a	b	c	d	e
UT-10/SA	125-1/4	120	32-5/8	68-1/4	51-3/4
UT-12/SA	143 1/2	144	39-1/8	82-5/8	60-7/8

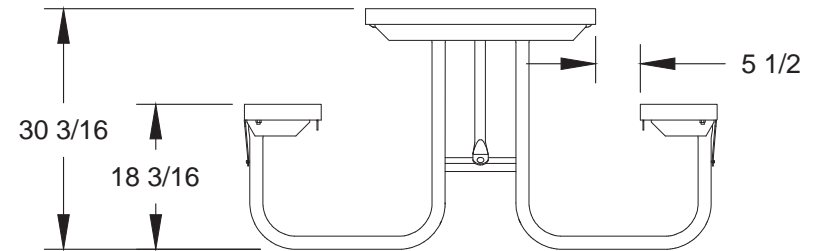

ALL DIMENSIONS IN INCHES

RJThomas Mfg. Co., Inc.
P.O. Box 946 • Cherokee, IA 51012-0946

DRAWN BY
WWM

TITLE **UT SERIES HEAVY DUTY 10 AND 12 FOOT SIDE ACCESS PORTABLE RECTANGULAR TABLE WITH ALUMINUM TOP AND SEATS**

DATE **1-5-17**

DWG. NO. **AI-1818**