

WXTH Series Raised Top 6 and 8 Foot Universal Access Table with Lumber Top and Seat Planks



Model WXTH/G-8UP 8 Ft. Raised Top, Portable, Universal Access Rectangular Table with Hot Dip Galvanized Frames and Untreated Southern Yellow Pine top and seats

- **Constructed specifically for heavy use areas**
- **Raised table top for greater wheelchair clearance**
- **Nontip, nontrip, walk-through design with wheelchair accessibility at each end**
- **Full capacity seating when wheelchairs are not in place**
- **All welded end frames are fabricated from 2-3/8" diameter steel pipe**
- **Die-formed center channel and diagonal braces align and strengthen entire table**
- **Frames are hot dip galvanized after fabrication for superior corrosion resistance**
- **Precision drilled, Untreated #1 Southern Yellow Pine Seat and Top Planks**
- **Die-formed end caps keep top planks aligned**
- **Limited Lifetime Warranty on frames**

AVAILABLE OPTIONS

6' or 8' lengths

Powder Coat Finish in choice of colors on steel frame components

Pressure treated #1 Southern Yellow Pine lumber (Cedar, Fir, or Redwood lumber when in stock)

SPECIFICATIONS:

- **WXTH Series** end frames are one-piece welded construction, fabricated from 2.375" (2-3/8") O.D. x 10 ga. wall steel pipe to meet 2" nominal steel pipe size specifications with 2" x 2" x 1/8" die-formed steel angle for attaching the seats and top. Bends are tightly formed to prevent tipping when weight is on one side.
- The frame design exceeds the ADA recommended wheelchair clearances under the table top of: 30" wide, 27" high and 24" total knee and toe clearance (19" knee + 5" toe) at each end of the table while maintaining the full seating capacity of the table for common use.
- Table frame design incorporates nontip, nontrip, walk-through design features.
- **Model WXTH/G-6** is a nom. 6 ft. in length.
- **Model WXTH/G-8** is a nom. 8 ft. in length.
- Nominal table height is 33". Frame design provides a nominal 31" of clearance from ground level to the underside of table. Nominal seat height is 19".
- Frames are supported by diagonal braces of 1-5/16" O.D. x 14 ga. wall steel pipe that connect to a die-formed steel channel designed to align and provide attachment to the table top.
- All fasteners are provided for assembly.
- **Standard:** All steel frame components are hot-dip galvanized after fabrication to ASTM-A123 to maintain an average zinc coating of 2.0 oz. per sq. ft. of surface area (indicated by "/G" in model no., e.g. WXTH/G-6UP).
- **Standard:** Lumber is Untreated #1 grade Southern Yellow Pine (indicated by "UP" in model no., e.g. WXTH/G-6UP) 2" x 10" nominal sized planks, kiln dried to reduce moisture content. All lumber is precision drilled to facilitate assembly and has all exposed edges removed to a 3/8" radius.
- Two 1-5/8" x 1-5/16" x 14 ga. x 28" pregalvanized steel end caps are provided to align ends of top planks.
- **Optional:** All steel frame components have powder coat finish. See Specification Bulletin #SPC-CO-001.
- **Optional:** Treated #1 Southern Yellow Pine is readily available and is pressure treated and kiln dried after treatment (KDAT) to preserve wood against decay. To specify, change "UP" in model no. to "TP", e.g. WXTH/G-6TP. (Cedar, Fir, and Redwood are available when in stock – please inquire.)
- **U.S. Patent Nos. D489,539; D490,992; D493,291; D496,799; D497,262; 6,918,630**

RJ Thomas Mfg. Co., Inc.

PO Box 946 • Cherokee, IA 51012-0946 • PH: 712-225-5115 • 800-762-5002 • FAX: 712-225-5796
E-mail: pilotrock@rjthomas.com • Web Site: <http://www.pilotrock.com>

© 2017 RJ Thomas Mfg. Co., Inc. PILOT ROCK® Park Products is a registered trademark of RJ Thomas Mfg. Co., Inc.

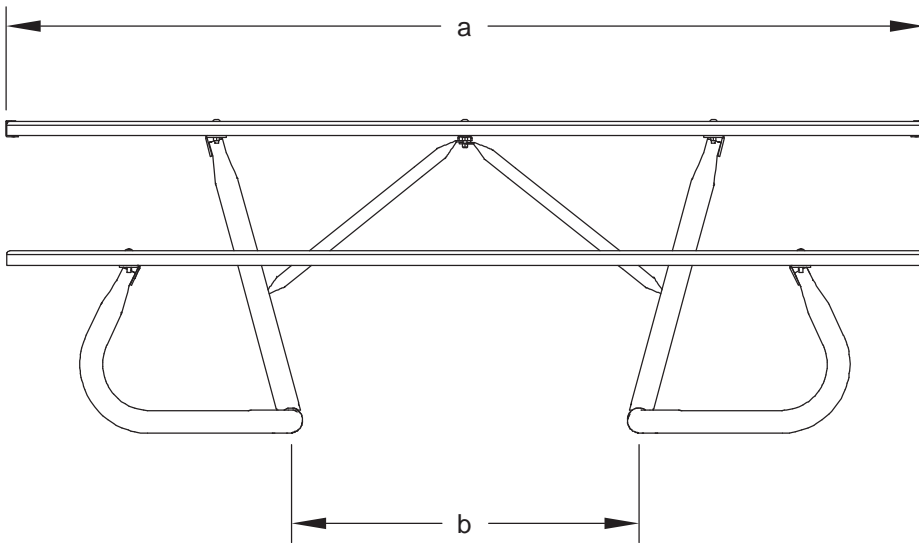
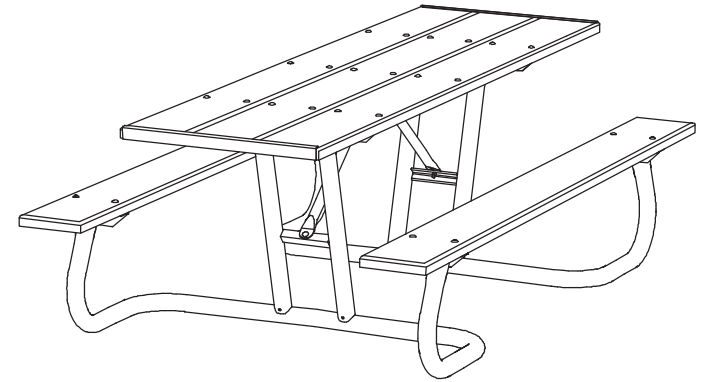
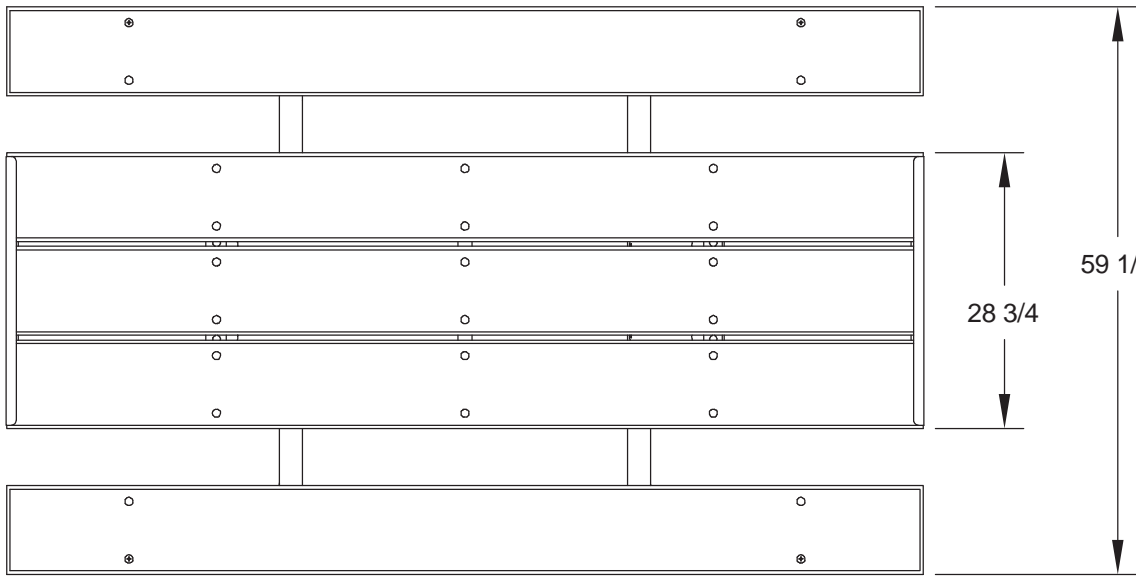

MODEL NUMBER	DIMENSION	
	a	b
WXTH-6	71 5/8	19
WXTH-8	95 5/8	36 1/4

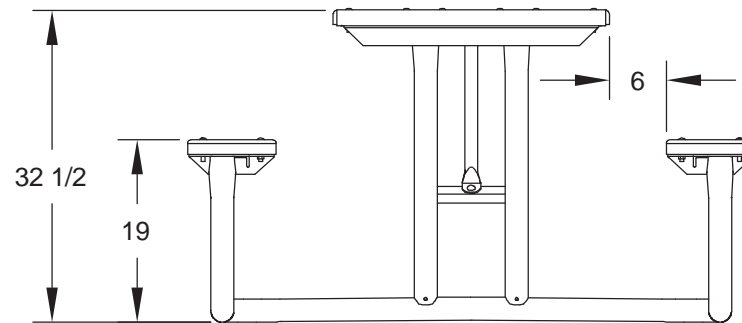

ALL DIMENSIONS IN INCHES

RJThomas Mfg. Co., Inc.
P.O. Box 946 • Cherokee, IA 51012-0946

DRAWN BY
WWM

TITLE **WXTH SERIES 6 AND 8 FOOT RAISED TOP UNIVERSAL ACCESS TABLES
WITH 2" X 10" LUMBER TOP AND SEAT PLANKS**

DATE 11-20-08

DWG. NO. **AI-1645**