

## XT Series 10 and 12 Foot Extra Heavy Duty Rectangular Tables with Lumber Top and Seats



*Model XT/G-10UP 10 Ft. Extra Heavy Duty Portable Rectangular Table with Hot Dip Galvanized Frames and Untreated Southern Yellow Pine Top and Seats*

- **Constructed specifically for heavy use areas**
- **Nontip, nontrip walk-through design**
- **All welded end frames are fabricated from 2-3/8" diameter steel pipe**
- **Die-formed center channel and diagonal braces align and strengthen entire table**
- **Frames are hot dip galvanized after fabrication for superior corrosion resistance**
- **Precision drilled, Untreated #1 Southern Yellow Pine top and seat planks**
- **Limited lifetime warranty on frames**

### **SPECIFICATIONS:**

- **XT Series** end frames are one-piece welded construction, fabricated from 2.375" (2-3/8") O.D. steel pipe to meet 2" nominal steel pipe size specifications with 2" x 2" x 3/16" A-36 structural grade steel angle for attaching the seats and top.
- Table frame design incorporates nontip, nontrip, walk-through design features. Bends are tightly formed to prevent tipping when weight is on one side.
- **Model XT/G-10UP** is a nominal 10 ft. long with three frames.
- **Model XT/G-12UP** is a nominal 12 ft. long with three frames.
- Nominal table height is 30". Nominal seat height is 18".
- Frames are supported by diagonal braces of 1-5/16" O.D. x 14 ga. wall steel pipe that connect to a die-formed steel channel designed to align and provide attachment to the table top.
- **Standard:** All frame components are be hot-dip galvanized after fabrication to ASTM-A123 to maintain an average zinc coating of 2.0 oz. per sq. ft. of surface area (indicated by "/G" in model no.), e.g. XT/G-10UP.
- All galvanized fasteners are provided for assembly.
- **Standard:** Lumber is Untreated #1 grade Southern Yellow Pine (indicated by "UP" in model no., e.g. XT/G-10UP) 2" x 10" nominal sized planks, kiln dried to reduce moisture content. All lumber is precision drilled to facilitate assembly and has all exposed edges removed to a 3/8" radius.
- **Optional:** Color choices of powder coated steel frame components. See Specification Bulletin #SPC-CO-001.
- **Optional:** Treated #1 Southern Yellow Pine is readily available and is pressure treated (KDAT) to preserve wood against decay. To specify, change "UP" in model no. to "TP", e.g. UT/G-10TP. (Cedar, Fir and Redwood are available when in stock -please inquire.)

### **AVAILABLE OPTIONS**

- **10' or 12' length**
- **Choice of colors of Powder Coated finish for steel frame components**
- **Pressure treated #1 Southern Yellow Pine lumber (Cedar, Fir, or Redwood lumber when in stock)**

## **RJThomas Mfg. Co., Inc.**

PO Box 946 • Cherokee, IA 51012-0946 • PH: 712-225-5115 • 800-762-5002 • FAX: 712-225-5796  
E-mail: pilotrock@rjthomas.com • Web Site: <http://www.pilotrock.com>

© 2008 RJThomas Mfg. Co., Inc. PILOT ROCK® Park Products is a registered trademark of RJThomas Mfg. Co., Inc.

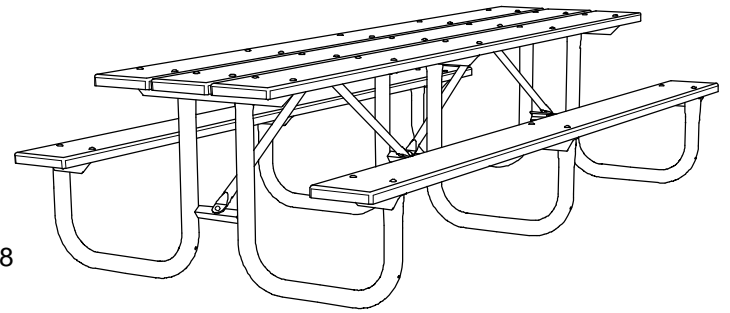
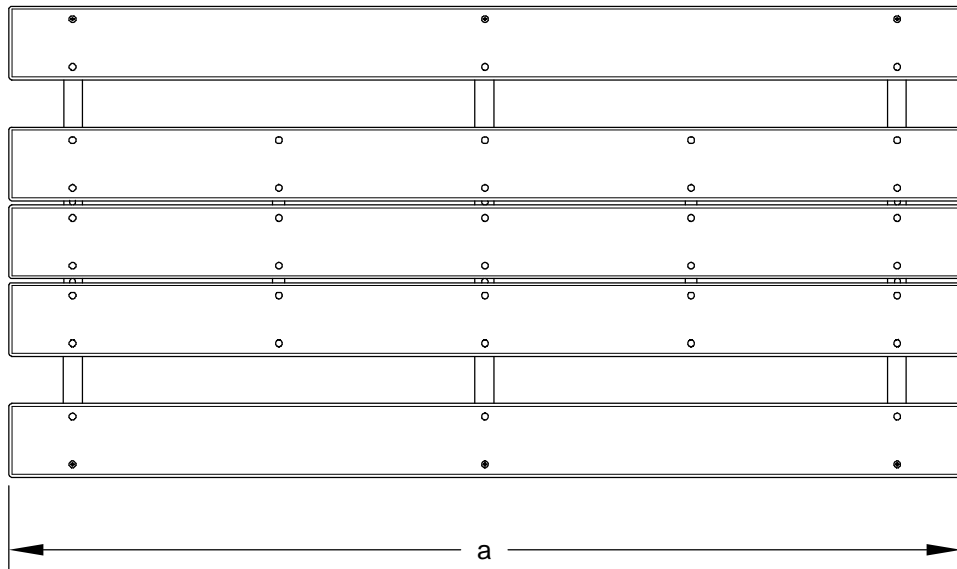

MODEL NUMBER	DIMENSION	
	a	b
XT/G-10	119-1/2	51-3/4
XT/G-12	143-1/2	70

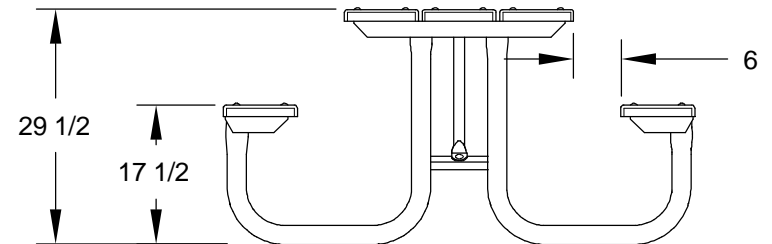
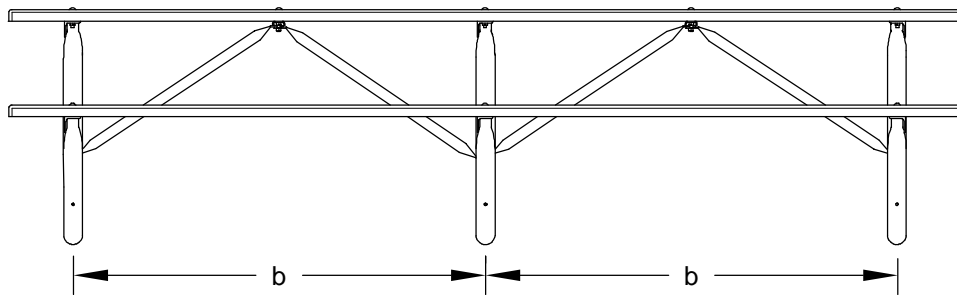

ALL DIMENSIONS IN INCHES

**RJThomas Mfg. Co., Inc.**  
P.O. Box 946 • Cherokee, IA 51012-0946

DRAWN BY  
**WWM**

TITLE XT SERIES EXTRA HEAVY DUTY 10 AND 12 FOOT PORTABLE RECTANGULAR TABLE  
WITH LUMBER TOP AND SEATS

DATE 11-24-08

DWG. NO. AI-1849