

XT Series 10 Foot Portable Rectangular Table with R-Type Thermo-plastic Coated Perforated Steel Top and Seats



*Model XT/G-10RN 10 Ft. Heavy Duty Portable Rectangular Table
with hot dip galvanized frames and
green R-Type thermo-plastic Coated perforated steel top and seats*

- **Constructed specifically for heavy use areas**
- **Nontip, nontrip walk-through design**
- **All welded end frames are fabricated from 2-3/8" diameter steel pipe**
- **Diagonal braces align and strengthen entire table**
- **Frames are hot dip galvanized after fabrication for superior corrosion resistance**
- **Thermo-plastic Coating heat fused to Perforated Steel Top and Seats for durability**
- **Thermo-plastic Coating formulated with U.V. stabilizers for ultraviolet protection**
- **Limited lifetime warranty on frames**

SPECIFICATIONS:

- **XT Series** end frames are one-piece welded construction, fabricated from 2.375" O.D. (2-3/8" O.D.) steel pipe to meet 2" nominal steel pipe size specifications with 2" x 2" x 1/8" die formed steel angle for attaching the seats and tops.
- Table frame design incorporates nontip, nontrip, walk-through design features. Bends are tightly formed to prevent tipping when weight is on one side.
- **Model XT/G-10** is nominal 10 ft. long with three frames.
- Nominal table height is 30". Nominal seat height is 18".
- Frames are supported by diagonal braces of 1-5/16" O.D. x 14 ga. steel pipe that connect to the underside of the table top.
- **Standard:** All steel frame components are hot-dip galvanized after fabrication to ASTM-A123 to maintain an average zinc coating of 2.0 oz. per sq. ft. of surface area (indicated by "/G" in model no.), e.g. XT/G-10RW.
- All galvanized fasteners are provided for assembly.
- **R-Type** table top (14 ga.) and seats (12 ga.) are each one-piece welded construction, fabricated from perforated steel, with 9/16" dia. holes in a 13/16" center to center in-line pattern, and 2" formed vertical edges on all sides and reinforced by a strap and angle substructure.
- **Standard:** All steel surfaces of the top and seats are covered with a thermo-plastic coating in a Brown color (indicated by "RW" in model no., e.g. XT/G-10RW). The UV-stabilized thermo-plastic coating is applied in a multi step process of material preparation and finish application designed to permanently heat fuse and bond the finish to the steel. The thermo-plastic polyethylene finish is impact resistant, does not support mold or mildew, and the textured matte surface is less susceptible to marring and scuffing.
- **Optional:** Color choices of powder coated steel frame components. See Specification Bulletin #SPC-CO-001.
- **Optional:** Color choices of Thermo-plastic coated steel components. For optional colors choices see Specification Bulletin #SPC-CO-001.

AVAILABLE OPTIONS

- **Powder Coat Finish in choice of colors for steel frame components**
- **Choice of colors of Thermo-plastic Coating**

RJ Thomas Mfg. Co., Inc.

PO Box 946 • Cherokee, IA 51012-0946 • PH: 712-225-5115 • 800-762-5002 • FAX: 712-225-5796
E-mail: pilotrock@rjthomas.com • Web Site: <http://www.pilotrock.com>

© 2019 RJ Thomas Mfg. Co., Inc. PILOT ROCK® Park Products is a registered trademark of RJ Thomas Mfg. Co., Inc.

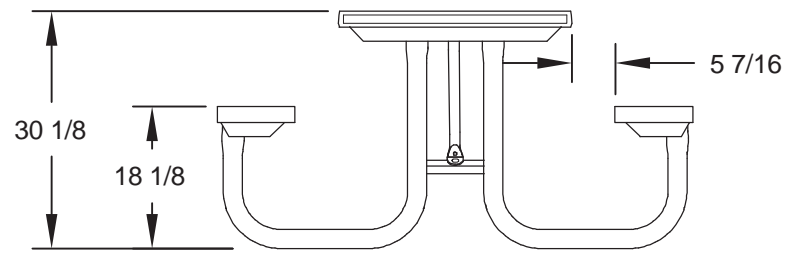
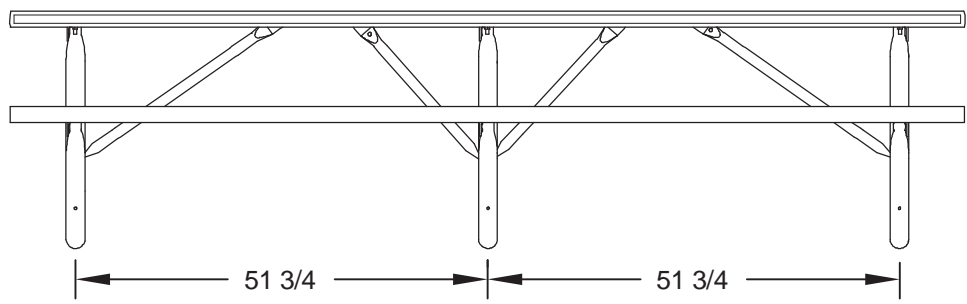
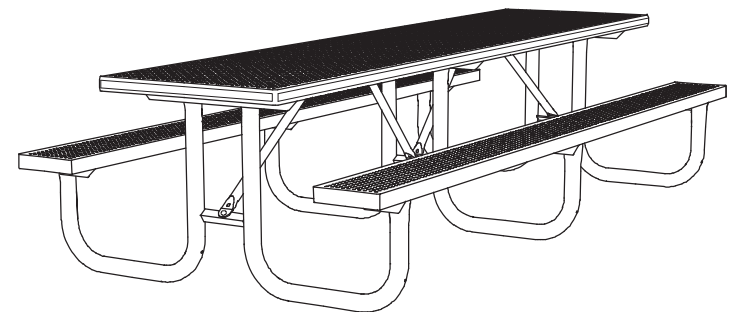
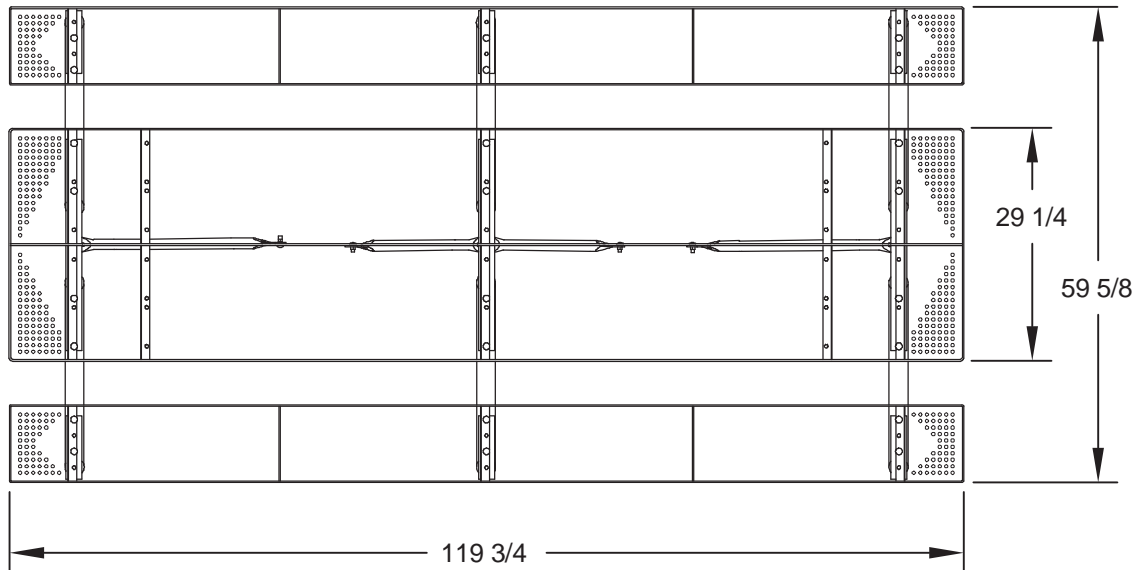

ALL DIMENSIONS IN INCHES

RJThomas Mfg. Co., Inc.
P.O. Box 946 • Cherokee, IA 51012-0946

DRAWN BY
WWM

TITLE **XT SERIES EXTRA HEAVY DUTY 10 FOOT PORTABLE RECTANGULAR TABLE WITH R-TYPE THERMO-PLASTIC COATED PERFORATED STEEL TOP AND SEATS**

DATE **3-05-10**
DWG. NO. **AI-1853**