

# XT Series Extra Heavy Duty Portable Rectangular Tables with Lumber



**Model XT/G-6UP** 6 Ft. Extra Heavy Duty  
Portable Rectangular Table with Hot Dip Galvanized Frame and  
Untreated Southern Yellow Pine Planks

- **Constructed specifically for heavy use areas**
- **Nontip, nontrip, walk-through design**
- **All welded end frames are fabricated from 2-3/8" diameter steel pipe**
- **Die-formed center channel and diagonal braces align and strengthen entire table**
- **Frames are hot dip galvanized after fabrication for superior corrosion resistance**
- **Precision drilled, Untreated #1 Southern Yellow Pine Seat and Top Planks**
- **Limited lifetime warranty on frames**

## **SPECIFICATIONS:**

- **XT Series** end frames are one-piece welded construction, fabricated from 2.375" O.D. (2-3/8" O.D.) steel pipe to meet 2" nominal steel pipe size specifications with 2" x 2" x 3/16" A-36 structural grade steel angle for attaching the seats and tops.
- Table frame design incorporates nontip, nontrip, walk-through design features. Bends are tightly formed to prevent tipping when weight is on one side.
- **Model XT/G-6** has a nom. 6 ft. length.
- **Model XT/G-8** has a nom. 8 ft. length.
- Nominal table height is 30". Nominal seat height is 18".
- Frames are supported by diagonal braces of 1-5/16" O.D. steel pipe that connect to a die-formed steel channel designed to align and provide attachment to the table top.
- **Standard:** All steel frame components are hot-dip galvanized after fabrication to ASTM-A123 to maintain an average zinc coating of 2.0 oz. per sq. ft. of surface area (indicated by "/G" in model no., e.g. XT/G-6UP).
- **Standard:** Lumber is Untreated #1 grade Southern Yellow Pine (indicated by "UP" in model no., e.g. XT/G-6UP) 2" x 10" nominal sized planks, kiln dried to reduce moisture content. All lumber is precision drilled for assembly and has all exposed edges removed to a 3/8" radius.
- All fasteners are provided for assembly.
- **Optional:** Color choices of powder coated steel frame components. See Specification Bulletin #SPC-CO-001.
- **Optional:** Treated #1 Southern Yellow Pine is readily available and is pressure treated and kiln dried after treatment (KDAT) to preserve wood against decay. To specify, change "UP" in model no. to "TP", e.g. XT/G-6TP. (Cedar, Fir, and Redwood are available when in stock – please inquire.)
- **Optional:** Table is provided with (2) backrest attachments to bolt to the table frame, consisting of (2) pair of backrest brackets and (2) lumber backrest planks.

## **AVAILABLE OPTIONS**

- 6' or 8' lengths
- Powder Coat Finish in choice of colors for steel frame components
- Pressure treated #1 Southern Yellow Pine lumber (Cedar, Fir, or Redwood lumber when in stock)
- Backrest attachments

## **RJThomas Mfg. Co., Inc.**

PO Box 946 • Cherokee, IA 51012-0946 • PH: 712-225-5115 • 800-762-5002 • FAX: 712-225-5796  
E-mail: pilotrock@rjthomas.com • Web Site: <http://www.pilotrock.com>

© 2008 RJThomas Mfg. Co., Inc. PILOT ROCK® Park Products is a registered trademark of RJThomas Mfg. Co., Inc.

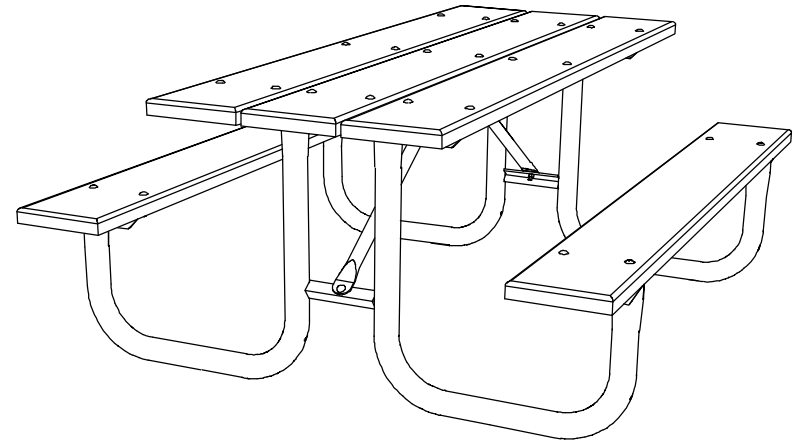
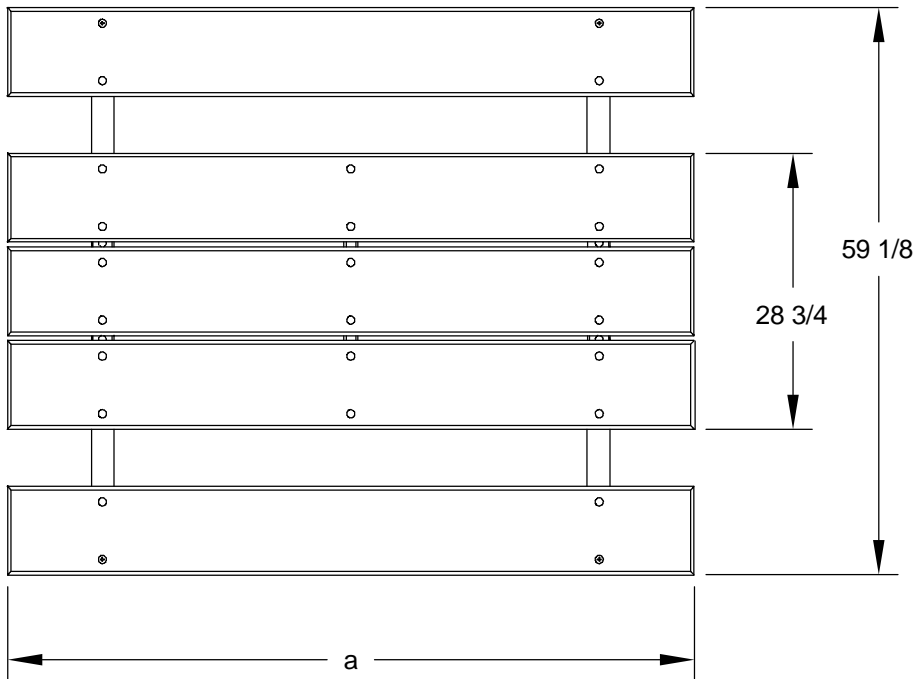

MODEL NUMBER	DIMENSION	
	a	b
XT/G-6	71-1/2	51-3/4
XT/G-8	95-1/2	70

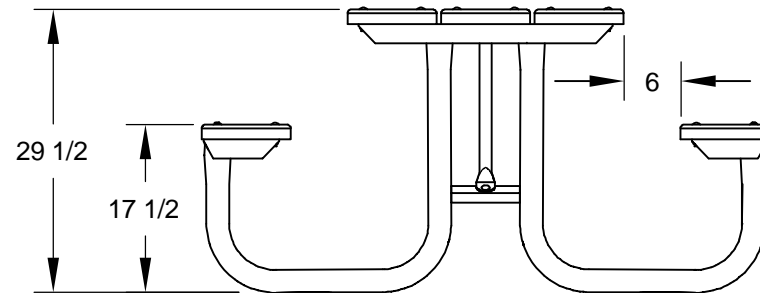
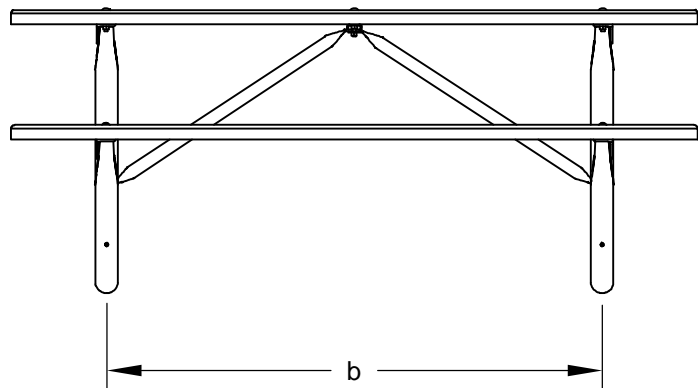

ALL DIMENSIONS IN INCHES

**RJThomas Mfg. Co., Inc.**  
P.O. Box 946 • Cherokee, IA 51012-0946

DRAWN BY  
**WWM**

TITLE XT SERIES 6 AND 8 FOOT PORTABLE RECTANGULAR TABLES WITH LUMBER TOP  
AND SEAT PLANKS

DATE 9-08-08

DWG. NO. **AI-1473**