



*Model PQT/G-4AL 5 Plank, 48" Square Top, Embedded Mount Table  
with Hot dip Galvanized Frame  
and Aluminum Top and Seat Planks*

- **Square design optimizes table top usage and creates a more intimate setting**
- **Square table fits into more compact areas**
- **Permanent embedded mounting**
- **Sturdy 6" square center pedestal, 3-1/2" diameter round radial seat supports**
- **Frames are hot dip galvanized after fabrication for superior corrosion resistance**
- **Seats and Top are Aluminum with a clear anodized maintenance-free finish**
- **Quality construction throughout**

## AVAILABLE OPTIONS

**3' or 4' square models**

**Powder Coat Finish in choice of colors for steel frame components**

**Powder Coat Finish in choice of colors for aluminum top and seats**

**Choice of two Umbrella styles with mounting hardware**

**Surface mount base plate**

## SPECIFICATIONS:

- **PQT Series** table frame incorporates a 6" square single center pedestal post designed to be embedded in a concrete footing.
- Four seat support frames are each a one-piece welded construction of 3-1/2" dia. x 11 ga. wall structural steel tubing, a 2-3/8" dia. 10 ga. wall tube, and 2" x 2" x 1/8" die formed steel angles designed to resist lateral torsion and deflection when loaded.
- Frame is designed in a theft-proof manner with all fasteners extending into the central post to prevent removal once the table is assembled.
- **Model PQT/G-3** has a nominal 3 ft. square top.
- **Model PQT/G-4** has a nominal 4 ft. square top.
- Nominal table height is 32-3/16". Nominal seat height is 20-1/4".
- Top planks are supported by a subframe of 2" x 2" x 1/8" die formed steel angle, 10 ga. steel channel, and 2-3/8" round tubing.
- All galvanized fasteners are provided for assembly.
- **Standard:** All steel frame components are hot-dip galvanized after fabrication to ASTM-A123 to maintain an average zinc coating of 2.0 oz. per sq. ft. of surface area (indicated by "/G" in model no., e.g. PQT/G-4AL).
- Aluminum is extruded 6063-T6 aluminum alloy in planks with dimensions equivalent to that of 2" x 10" nominal sized lumber. The plank design is 1-3/4" x 9-5/8" with four structural reinforcement ribs for greater rigidity. Aluminum planks are provided with a clear anodized finish as per anodizing specification 204 R1. Aluminum clips to fasten planks to frames are included.
- Channel end caps are of extruded 6063-T6 aluminum alloy provided with a clear anodized finish as per anodizing specification 204 R1. End caps are press fitted over ends of aluminum planks and mechanically fastened in place at the factory.
- Table tops are assembled into single units at the factory with one-piece end caps across each end.
- **Optional:** All steel frame components have powder coat finish. For color choices see Specification Bulletin #SPC-CO-001.
- **Optional:** Aluminum top and seat planks and end caps have powder coat finish. For color choices see Specification Bulletin #SPC-CO-001.
- **Optional:** Table is provided with umbrella holes in table tops and cup and collar sets for mounting umbrellas. To specify, add "/U" to the end of the model no., e.g. PQT/G-3AL/U.
- **Optional:** Frame is provided with a 3/8" x 15-3/4" x 15-3/4" steel base plate to bolt table to existing concrete pad. To specify add "/P" after the "PQT" in the model no., e.g. PQT/P/G-4AL. (Anchor bolts not included.)

**RJ Thomas Mfg. Co., Inc.**

PO Box 946 • Cherokee, IA 51012-0946 • PH: 712-225-5115 • 800-762-5002 • FAX: 712-225-5796

E-mail: [pilotrock@rjthomas.com](mailto:pilotrock@rjthomas.com) • Web Site: <https://www.pilotrock.com>

© 2023 RJ Thomas Mfg. Co., Inc. PILOT ROCK® Park Products is a registered trademark of RJ Thomas Mfg. Co., Inc.

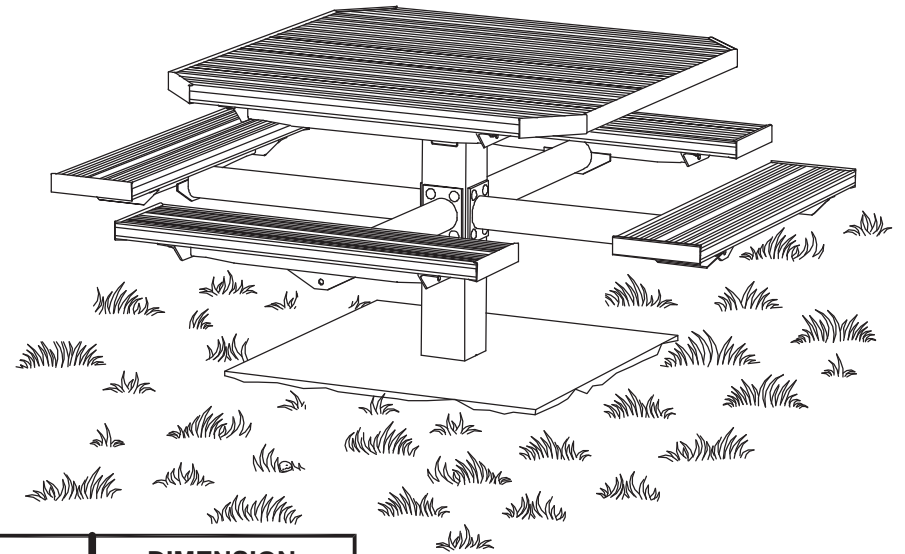
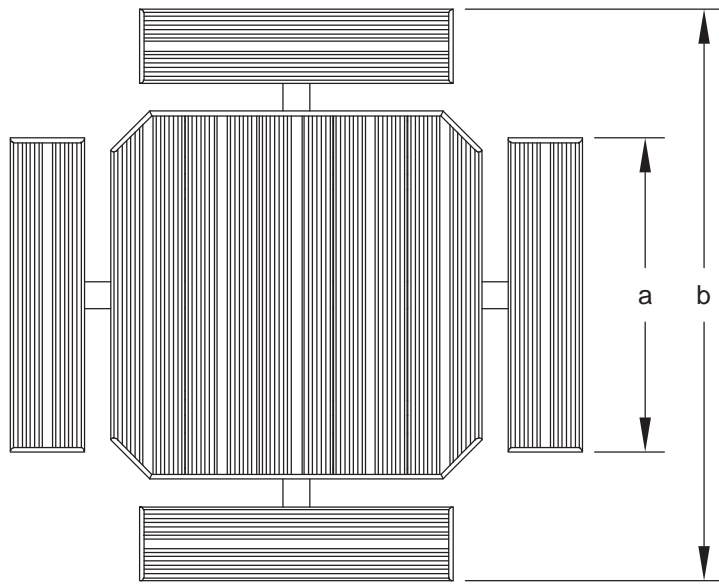

MODEL NUMBER	DIMENSION	
	a	b
PQT-3	33 29/32	68 1/2
PQT-4	40 15/16	74 5/8

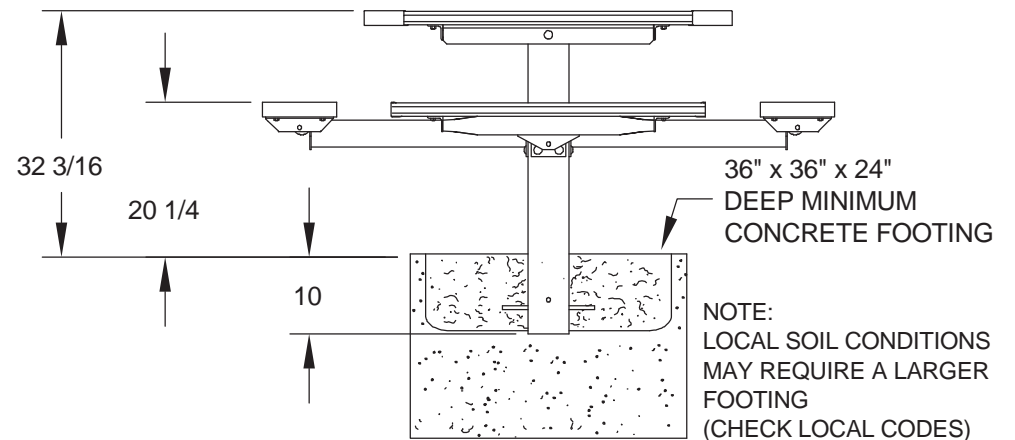
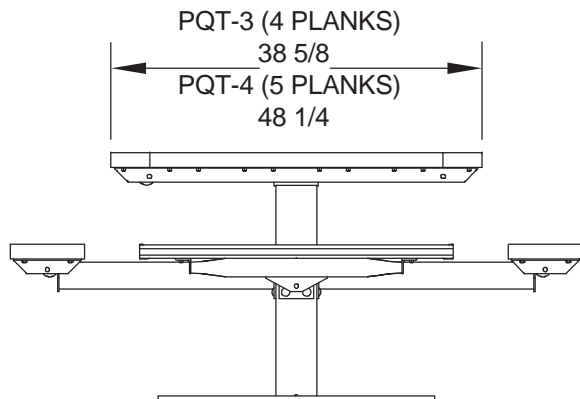

ALL DIMENSIONS IN INCHES

**RJThomas Mfg. Co., Inc.**  
P.O. Box 946 • Cherokee, IA 51012-0946

DRAWN BY  
**WWM**

TITLE **PQT SERIES 3 AND 4 FOOT EMBEDDED MOUNT SQUARE SINGLE PEDESTAL TABLE WITH ALUMINUM TOP AND SEAT PLANKS**

DATE 10-31-08

DWG. NO. **AI-1697**