



**Model RBB/N-6C26** 6 Ft. Surface Mount Bench  
with green recycled plastic frames  
and cedar colored recycled plastic 2" x 6" planks.  
Shown with optional green resin filled routed lettering.

- **Constructed from 100% Recycled Plastic with solid color and U.V. stabilizer for ultraviolet protection**
- **Match or mix frames and planks in a choice of colors of Recycled Plastic**
- **Precision drilled plastic planks**

#### **SPECIFICATIONS:**

- **Model RBB** bench is made from 100% recycled plastic, a combination of post-consumer and post-industrial plastic. Frames are a single piece of solid, molded plastic. Planks are molded in nominal lumber dimensions.
- **Model RBB-4** is a nom. 4 ft. in length with two (2) frames.
- **Model RBB-6** is a nom. 6 ft. in length with three (3) frames.
- **Standard:** Frames are made of 100% Recycled Plastic molded with solid Brown color (indicated by "/W" in model no., e.g. RBB/W-4C24) formed throughout and a U.V. stabilizer added for ultra-violet protection.
- **Standard:** Seat and back planks are made of 100% Recycled Plastic molded with solid Cedar color (indicated by "C" in second half of model no., e.g. RBB/W-4C24) formed throughout and a U.V. stabilizer added for ultra-violet protection. Planks are 2" x 4" nominal size (indicated by "24" at end of model no., e.g. RBB/W-4C24)
- Stainless steel Phillips-head screws are provided for assembly.
- **Optional:** Color choices of Recycled Plastic components. For optional colors choices see Specification Bulletin #SPC-CO-001.
- **Optional:** Seat and back planks are available in 2" x 6" or 2" x 10" nominal sizes. Indicate choice by changing "24" at end of model no. to "26" for 2" x 6", e.g. RBB/W-4C26; or "21" for 2" x 10", e.g. RBB/W-4C21.

#### **AVAILABLE OPTIONS**

- **4' or 6' models**
- **Choice of colors of Recycled Plastic**
- **Custom Lettering and Plaques available (call for details)**

**RJ Thomas Mfg. Co., Inc.**

PO Box 946 • Cherokee, IA 51012-0946 • PH: 712-225-5115 • 800-762-5002 • FAX: 712-225-5796  
E-mail: pilotrock@rjthomas.com • Web Site: <http://www.pilotrock.com>

© 2008 RJ Thomas Mfg. Co., Inc. PILOT ROCK® Park Products is a registered trademark of RJ Thomas Mfg. Co., Inc.

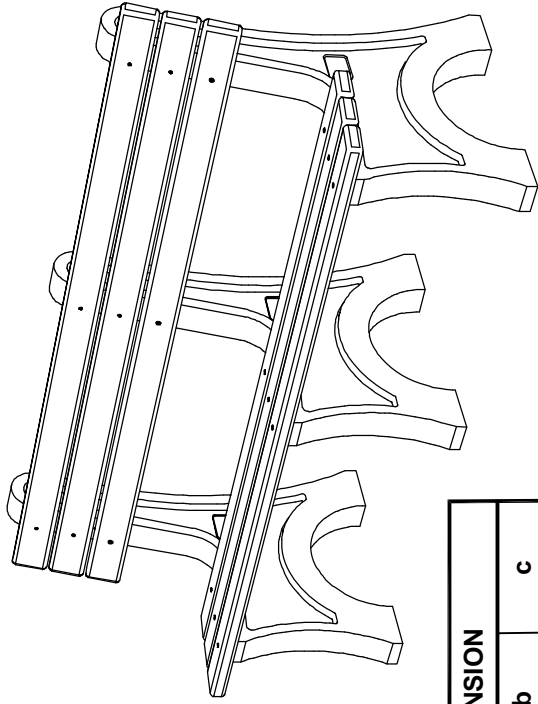
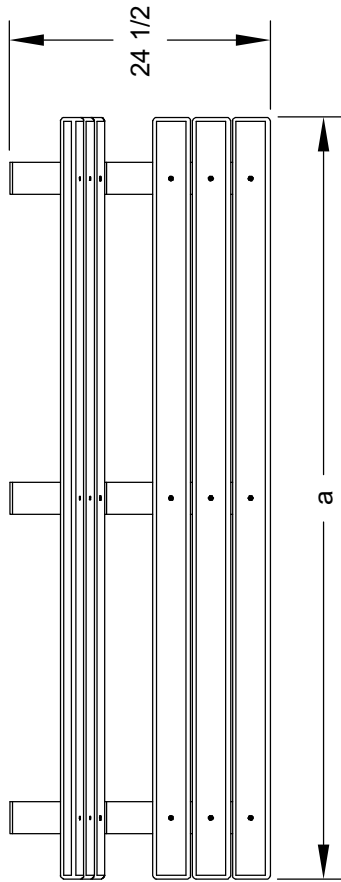

MODEL NUMBER	DIMENSION		
	a	b	c
RBB-4	47-1/2	N/A	36
RBB-6	71-1/2	30	60

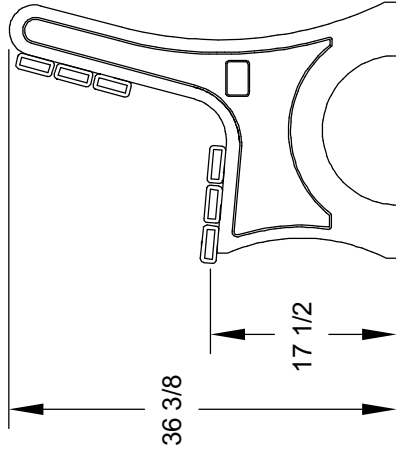
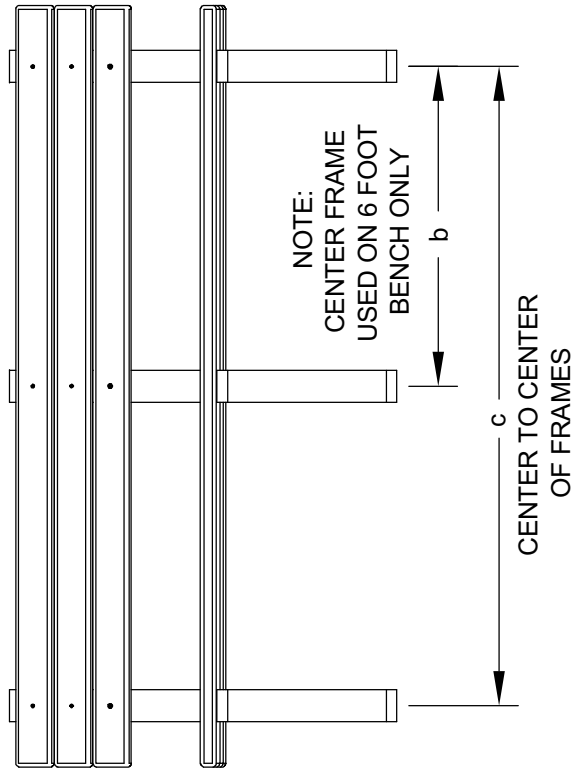

ALL DIMENSIONS IN INCHES

**RJ Thomas Mfg. Co., Inc.**  
 P.O. Box 946 • Cherokee, IA 51012-0946

DRAWN BY  
**WWM**

TITLE MODEL RBB 4 AND 6 FOOT SURFACE MOUNT 100% RECYCLED PLASTIC BENCH  
 WITH 2" X 4" SEAT AND BACK PLANKS

DATE 9-04-08

DWG. NO. **AI-1637**