



Model SQT3/CY-4PR/E Wheelchair accessible square portable table with Yellow Powder Coated frames and Red Recycled Plastic top and seats. Top extended one foot on open side.

- **Three seats and one open side for wheelchair access**
- **Square design optimizes table top usage and creates a more intimate setting**
- **Nontip, nontrip walk-through design**
- **All welded corner frames are fabricated from 1-1/2" diameter steel pipe**
- **Cross braces strengthen the table**
- **Frames are hot dip galvanized after fabrication for superior corrosion resistance**
- **100% Recycled Plastic Seat and Top Planks with solid color and U.V. stabilizer for ultraviolet protection**
- **Quality construction throughout**

SPECIFICATIONS:

- **Model SQT3-4** has a nominal 4' x 5' top. Overall dimensions shall be 73-3/8" x 75-1/8".
- Four corner frames are each a one-piece welded construction made from 1-1/2" dia. x 1/8" wall structural steel tubing and seat supports of 1-3/4" x 1-3/4" x 1/8" die formed steel angle. Two corner frames have opposing seat legs removed to provide a wheelchair accessible space under the extended side of the table top.
- Table frame design incorporates nontip, nontrip, walk-through features. Bends are tightly formed to prevent tipping when weight is on one side.
- Table top is extended 12" over open side of table creating a wheelchair space of 28" wide at frames, 19" deep, and 27" from ground to bottom of table top (This is indicated by "/E" in model no., e.g. SQT3/G-4PC/E).
- Nominal table height is 30". Nominal seat height is 17-1/2".
- Corner frames are connected by two cross braces constructed of 1-5/16" O.D. steel pipe.
- Top planks are supported and attached to corner frames by two 1-3/4" x 1-3/4" x 1/8" die formed steel angles.
- All fasteners are provided for assembly.
- **Standard:** All steel frame components are hot-dip galvanized after fabrication to ASTM-A123 to maintain an average zinc coating of 2.0 oz. per sq. ft. of surface area (indicated by "/G" in model no., e.g. SQT3/G-4PC/E).
- **Standard:** Top and seats are made of 100% Recycled Plastic molded into 2" x 10" nominal sized planks with solid Cedar color (indicated by PC in model no., e.g. SQT3/G-6PC/E) formed throughout and a U.V. stabilizer added for ultra-violet protection.
- **Optional:** All steel frame components have powder coat finish. See Specification Bulletin #SPC-CO-001.
- **Optional:** Color choices of Recycled Plastic components. See Specification Bulletin #SPC-CO-001.

AVAILABLE OPTIONS

- Powder Coat Finish in choice of colors for steel frame components
- Choice of colors of Recycled Plastic

RJ Thomas Mfg. Co., Inc.

PO Box 946 • Cherokee, IA 51012-0946 • PH: 712-225-5115 • 800-762-5002 • FAX: 712-225-5796
E-mail: pilotrock@rjthomas.com • Web Site: <https://www.pilotrock.com>

© 2021 RJ Thomas Mfg. Co., Inc. PILOT ROCK® Park Products is a registered trademark of RJ Thomas Mfg. Co., Inc.

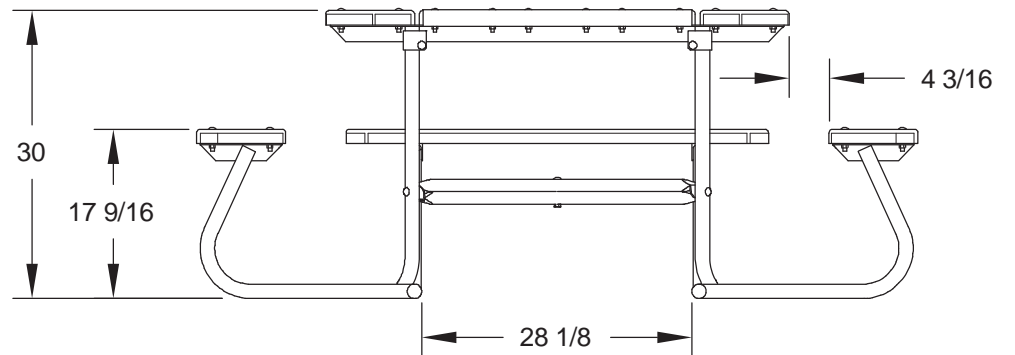
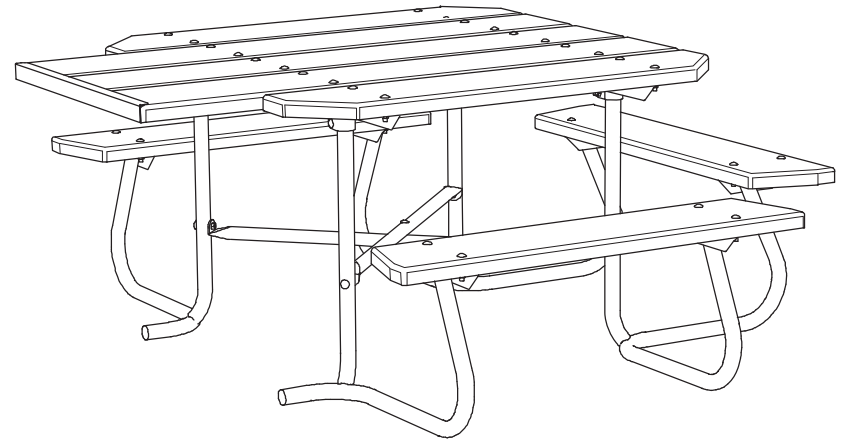
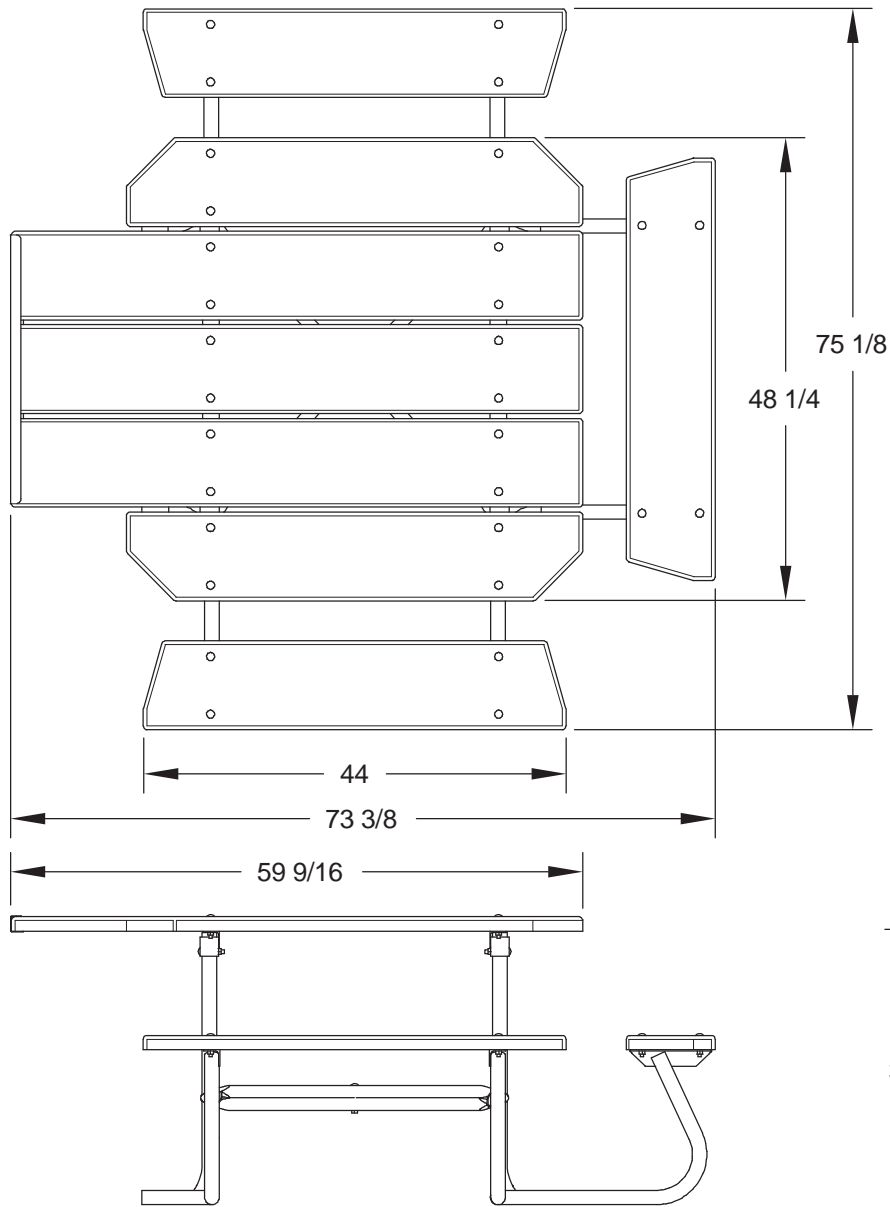

ALL DIMENSIONS IN INCHES

ALL DIMENSIONS IN INCHES

RJThomas Mfg. Co., Inc.
P.O. Box 946 • Cherokee, IA 51012-0946

DRAWN BY
WWM

TITLE **SQT3-4 SERIES 4 FOOT PORTABLE SQUARE TABLE WITH RECYCLED PLASTIC SEATS AND TOP TOP EXTENDED ONE FOOT ON OPEN SIDE**

DATE **11-07-08**

DWG. NO. **AI-1833**