

UT Series Heavy Duty Portable Rectangular Table with Lumber Top and Seats



*Model UT/G-6UP 6 Ft. Portable Rectangular Table
with Hot Dip Galvanized Frame
and Untreated Southern Yellow Pine Planks*

- **Nontip, nontrip, walk-through design**
- **Strong 1-5/8" diameter all welded, steel pipe end frame construction**
- **Precision drilled, Untreated #1 Southern Yellow Pine seat and top planks**
- **Frames are hot-dip galvanized after fabrication for superior corrosion resistance**
- **Diagonal bracing for strength and rigidity**
- **Die-formed center channel under table top to support and align top planks**
- **Limited Lifetime Warranty on frames**

SPECIFICATIONS:

- **UT Series** end frames are one-piece welded construction, fabricated from 1.660" O.D. (1-5/8" O.D.) steel pipe to meet 1-1/4" nominal pipe size specifications with 2" x 2" x 1/8" die formed steel angle for attaching the seats and tops.
- Table frame design incorporates nontip, nontrip, walk-through design features. Bends are tightly formed to prevent tipping when weight is on one side.
- Nominal table height is 30". Nominal seat height is 18".
- **Model UT/G-6** has a nominal 6 ft. length.
- **Model UT/G-8** has a nominal 8 ft. length.
- Frames are supported by diagonal braces of 1-5/16" O.D. steel pipe that connects to a die-formed steel channel designed to align and provide attachment to the table top.
- All fasteners are provided for assembly.
- **Standard:** All steel frame components are hot-dip galvanized after fabrication to ASTM-A123 to maintain an average zinc coating of 2.0 oz. per sq. ft. of surface area (indicated by "/G" in model no., e.g. UT/G-6UP).
- **Standard:** Lumber is Untreated #1 grade Southern Yellow Pine (indicated by "UP" in model no., e.g. UT/G-6UP) 2" x 10" nominal sized planks, kiln dried to reduce moisture content. All lumber is precision drilled to facilitate assembly and has all exposed edges removed to a 3/8" radius.
- **Optional:** All steel frame components have powder coat finish. See Specification Bulletin #SPC-CO-001.
- **Optional:** Treated #1 Southern Yellow Pine is readily available and is pressure treated and kiln dried after treatment (KDAT) to preserve wood against decay. To specify, change "UP" in model no. to "TP", e.g. UT/G-6TP. (Cedar, Fir, and Redwood are available when in stock – please inquire.)
- **Optional:** Table is provided with (2) backrest attachments to bolt to the table frame, consisting of (2) pair of backrest brackets and (2) lumber backrest planks.

AVAILABLE OPTIONS

- 6' or 8' lengths
- Powder Coat Finish in choice of colors on frame components
- Pressure treated #1 Southern Yellow Pine lumber (Cedar, Fir, or Redwood lumber when in stock)
- Backrest attachments

RJ Thomas Mfg. Co., Inc.

PO Box 946 • Cherokee, IA 51012-0946 • PH: 712-225-5115 • 800-762-5002 • FAX: 712-225-5796
E-mail: pilotrock@rjthomas.com • Web Site: <http://www.pilotrock.com>

© 2017 RJ Thomas Mfg. Co., Inc. PILOT ROCK® Park Products is a registered trademark of RJ Thomas Mfg. Co., Inc.

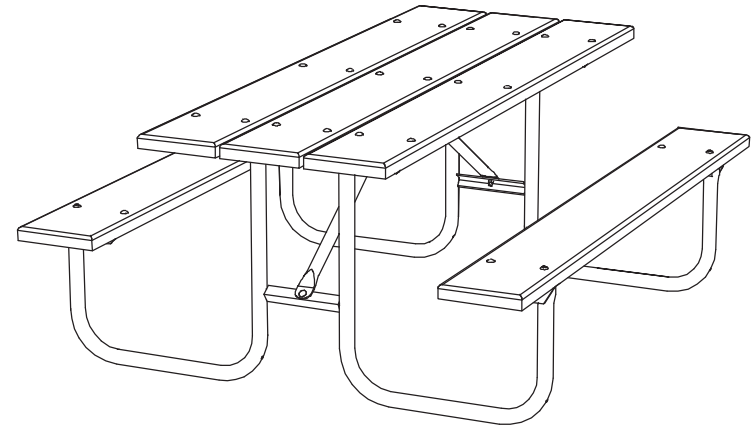
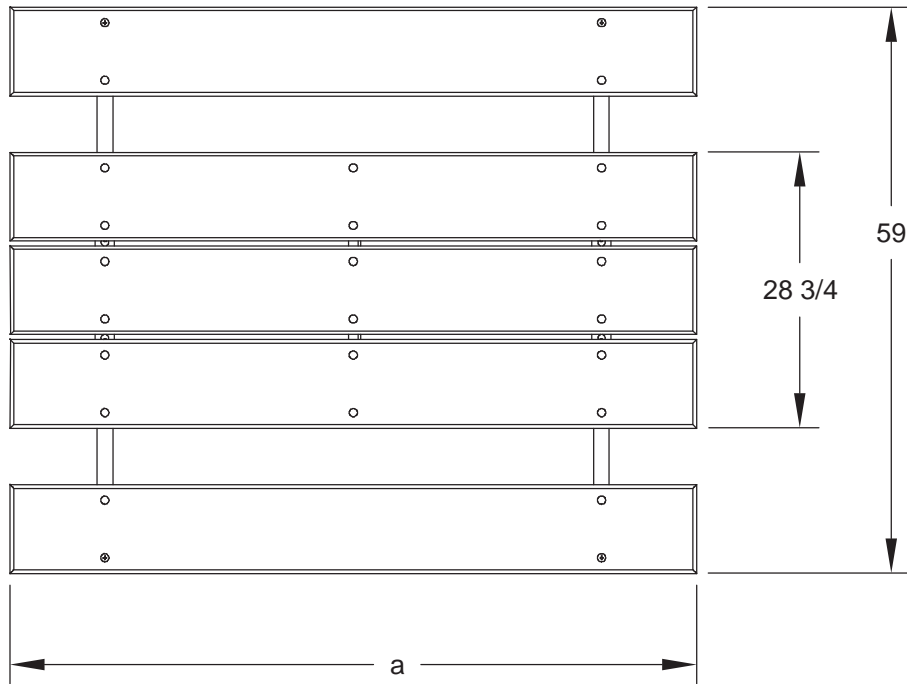

MODEL NUMBER	DIMENSION	
	a	b
UT/G-6	71 1/2	51 3/4
UT/G-8	95 1/2	70

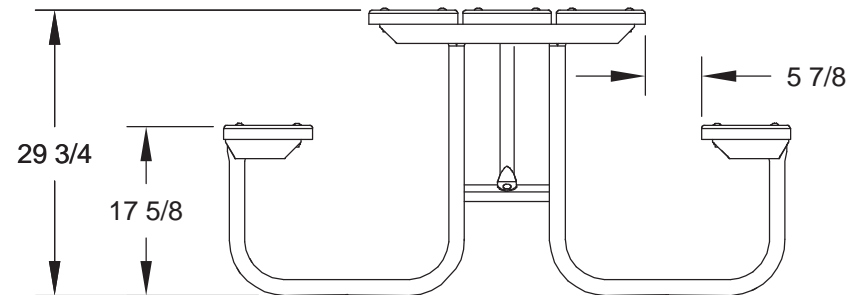
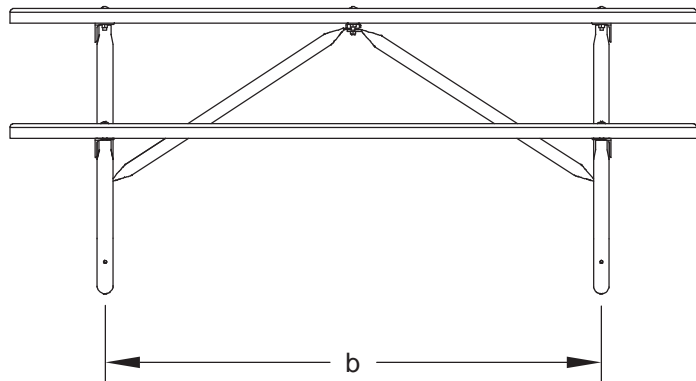

ALL DIMENSIONS IN INCHES

RJThomas Mfg. Co., Inc.
P.O. Box 946 • Cherokee, IA 51012-0946

DRAWN BY
WWM

TITLE UT SERIES 6 AND 8 FOOT PORTABLE RECTANGULAR TABLES WITH LUMBER
TOP AND SEAT PLANKS

DATE 11-12-08

DWG. NO. AI-1489