

## B132 Series 4, 6, and 8 Foot Square Frame Contour Bench with Construction Heart Redwood Planks



*Model B132/CW-8CO Square Frame Bench, 8 ft. long with brown powder coated frames and construction heart redwood planks*

- **Permanent surface mount installation**
- **11 and 14 ga. square and rectangular steel tube frame construction**
- **Construction Heart Redwood planks installed in frames at factory**
- **Simple bolt together assembly of four pieces**
- **Powder coat finish on frames**

### SPECIFICATIONS:

- **B132 Series** bench frames are a bolt together assembly of welded components. Seat and back frames are 14 ga. wall x 1" x 2" rectangular steel tube. End frames are fabricated from 11 ga. wall x 2" x 2" square tube and include armrests in the design. 1-1/2" x 1/2" x 1/8" steel channels are welded into the back and seat frames to secure the planks. A welded steel foot on each leg provides a 9/16" diameter hole for permanently anchoring bench to hard surfaces (anchors not included). Exposed ends of tubing are permanently sealed with welded-on steel end caps.
- **Model B132-4** is a nominal 4 ft. long.
- **Model B132-6** is a nominal 6 ft. long.
- **Model B132-8** is a nominal 8 ft. long.
- Nominal seat height is 17".
- **Standard:** All steel frame components have a black powder coat finish (indicated by "/CB" in model no., e.g. B132/CB-4CO).
- **Standard:** Back frame has 1" x 4" (nom.) and seat frame has 2" x 4" (nom.) construction heart redwood planks (indicated by "CO" in model no., e.g. B132/CB-4CO) set flush with the face of the frame to provide an even surface. Planks run length-wise in the seat frame and vertically in the back frame with a slight gap between them. Back and seat frames ship with planks factory installed, using galvanized fasteners.
- All stainless steel fasteners are provided for steel component assembly.
- **Optional:** Color choices of powder coat finish on steel frame components. See Specification Bulletin #SPC-CO-001.
- **Optional:** Model ANC3-4 Anchor Kit for permanent hard surface installation.

### AVAILABLE OPTIONS

- 4', 6', or 8' lengths
- Choice of colors of powder coat finish on steel frame components

### RJThomas Mfg. Co., Inc.

PO Box 946 • Cherokee, IA 51012-0946 • PH: 712-225-5115 • 800-762-5002 • FAX: 712-225-5796

E-Mail: [pilotrock@rjthomas.com](mailto:pilotrock@rjthomas.com) • Web Site: <http://www.pilotrock.com>

© 2012 RJThomas Mfg. Co., Inc. PILOT ROCK® Park Products is a registered trademark of RJThomas Mfg. Co., Inc.

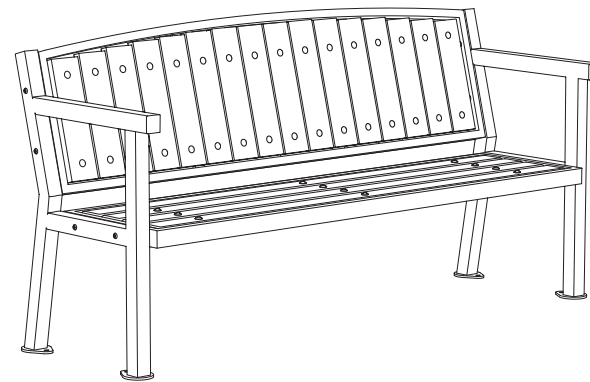
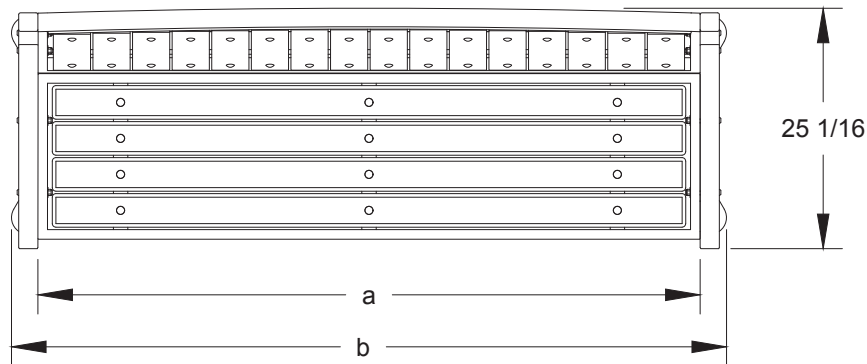

MODEL	DIMENSION		
	a	b	c
B132-4	44 1/4	49 3/4	46 1/4
B132-6	69	74 1/2	71
B132-8	93 3/4	99 1/4	95 3/4

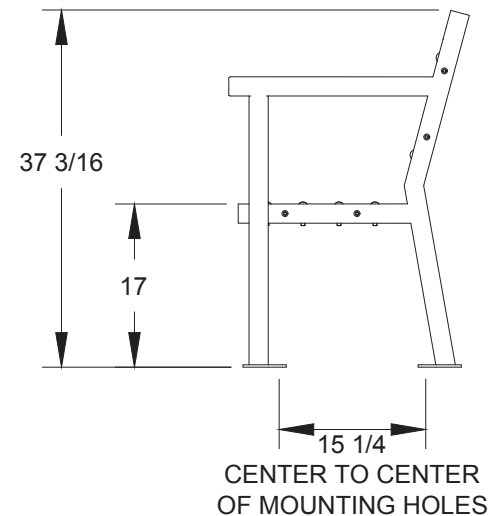
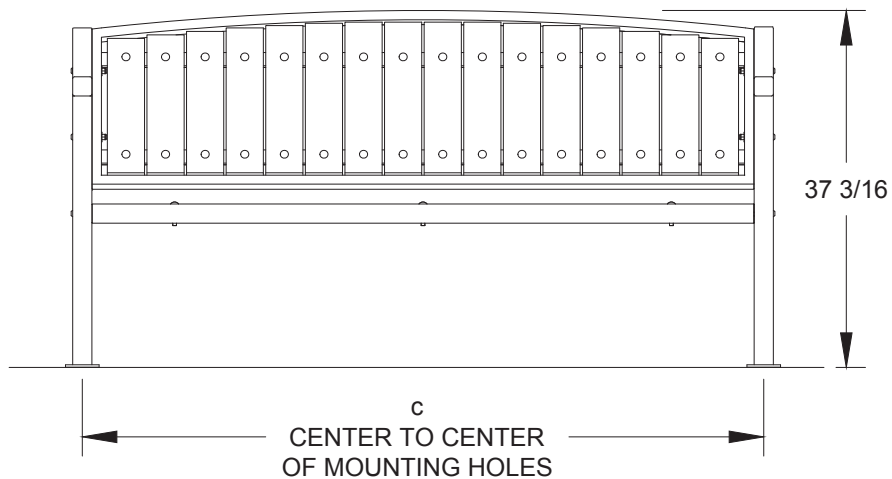

ALL DIMENSIONS IN INCHES

**RJThomas Mfg. Co., Inc.**  
P.O. Box 946 • Cherokee, IA 51012-0946

DRAWN BY  
**WWM**

TITLE MODEL B132 4, 6, AND 8 FOOT SURFACE MOUNT SQUARE FRAME CONTOUR  
BENCH WITH LUMBER PLANKS

DATE 8-11-17

DWG. NO. AI-2022