



*Model UT/G-12UP/SA 12 Ft. Wheelchair Accessible Heavy Duty Portable Rectangular Table with Hot Dip Galvanized Frames and Untreated Pine top and seats. Table provides side access for two wheelchairs.*

- **ADA compliant access for two wheelchair**
- **Nontip, nontrip, walk-through design**
- **All welded end frames are fabricated from 1.66" diameter steel pipe**
- **Die-formed center channel and diagonal braces align and strengthen entire table**
- **Frames are hot dip galvanized after fabrication for superior corrosion resistance**
- **Precision drilled, Untreated #1 Southern Yellow Pine Top and seat Planks**
- **Limited lifetime warranty on frames**

#### **AVAILABLE OPTIONS**

**10' or 12' length**

**Powder Coat Finish in choice of colors for steel frame components**

**Pressure treated #1 Southern Yellow Pine lumber (Cedar, Fir, or Redwood lumber when in stock)**

#### **SPECIFICATIONS:**

- **UT Series** end frames are one-piece welded construction, fabricated from 1.660" O.D. (1-5/8" O.D.) steel pipe to meet 1-1/4" nominal pipe size specifications with 2" x 2" x 1/8" die formed steel angle for attaching the seats and top.
- Table frame design incorporates nontip, nontrip, walk-through design features.
- Table provides two wheelchair spaces created by attaching one short seat and one long seat to end frames diagonally opposite each other. Short seats are supported by a 11 ga. steel plate bracket. Gap between seats create a ADA recommended space of 30" wide, 19" deep, and 27" from ground to bottom of table top for knee space, and minimum 9" above ground extending a total of 24" deep for toe space. Indicated by "/SA" at end of model no., e.g. UT/G-10UP/SA.
- Nominal table height, 30". Nominal seat height, 18".
- **Model UT/G-10UP/SA** is a nominal 10 ft. long with three frames, one 21-3/4" long seat and one 67-3/4" long seat on each side.
- **Model UT/G-12UP/SA** is a nominal 12 ft. long with three frames, one 21-3/4" long seat and one 82-5/8" long seat on each side.
- Frames are supported by diagonal braces of 1-5/16" O.D. x 14 ga. wall steel pipe that connect to a die-formed steel channel designed to align and provide attachment to the table top.
- **Standard:** All steel frame components are hot-dip galvanized after fabrication to ASTM-A123 to maintain an average zinc coating of 2.0 oz. per sq. ft. of surface area (indicated by "/G" in model no., e.g. UT/G-10UP/SA).
- All fasteners are provided for assembly.
- **Standard:** Lumber is Untreated #1 grade Southern Yellow Pine (indicated by "UP" in model no., e.g. UT/G-10UP/SA) 2" x 10" nominal sized planks, kiln dried to reduce moisture content. All lumber is precision drilled to facilitate assembly and has all exposed edges removed to a 3/8" radius.
- **Optional:** All steel frame components have powder coat finish. See Specification Bulletin #SPC-CO-001.
- **Optional:** Treated #1 Southern Yellow Pine is readily available and is pressure treated (KDAT) to preserve wood against decay. To specify, change "UP" in model no. to "TP", e.g. UT/G-10TP/SA. (Cedar, Fir and Redwood are available when in stock –please inquire.)

**RJ Thomas Mfg. Co., Inc.**

PO Box 946 • Cherokee, IA 51012-0946 • PH: 712-225-5115 • 800-762-5002 • FAX: 712-225-5796  
E-mail: pilotrock@rjthomas.com • Web Site: <http://www.pilotrock.com>

© 2017 RJ Thomas Mfg. Co., Inc. PILOT ROCK® Park Products is a registered trademark of RJ Thomas Mfg. Co., Inc.

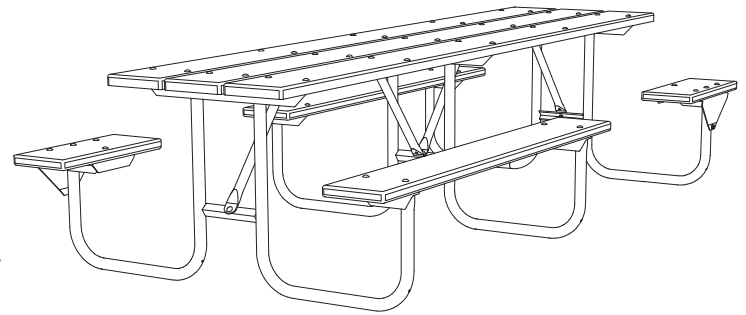
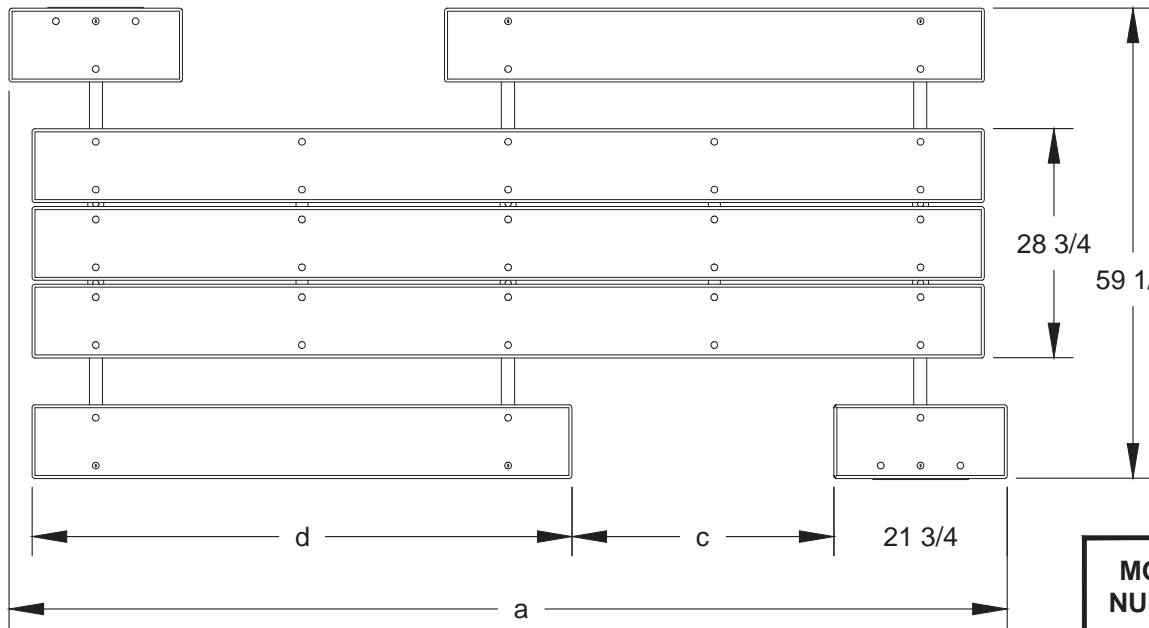

| MODEL NUMBER | DIMENSION |         |        |        |        |
|--------------|-----------|---------|--------|--------|--------|
|              | a         | b       | c      | d      | e      |
| UT-10/SA     | 125-1/4   | 119-1/2 | 32-7/8 | 67-3/4 | 51-3/4 |
| UT-12/SA     | 143-1/2   | 143-1/2 | 39-1/8 | 82-5/8 | 60-7/8 |

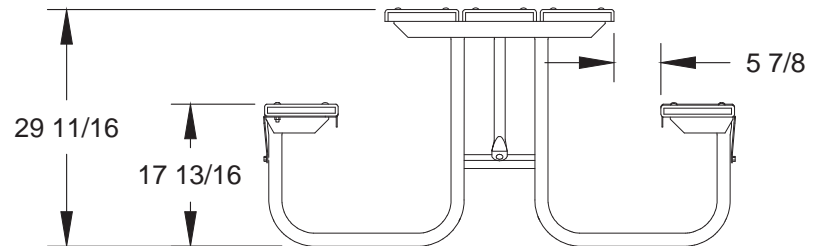
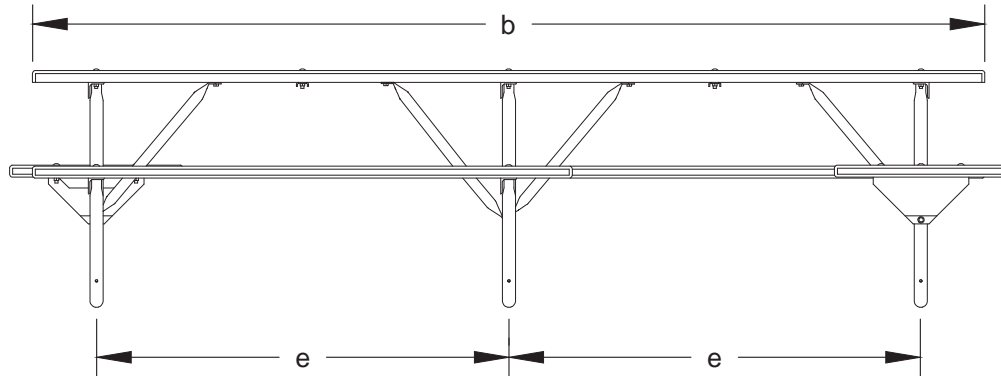

ALL DIMENSIONS IN INCHES

**RJThomas Mfg. Co., Inc.**  
P.O. Box 946 • Cherokee, IA 51012-0946

DRAWN BY  
**WWM**

TITLE **UT SERIES HEAVY DUTY 10 AND 12 FOOT SIDE ACCESS PORTABLE RECTANGULAR TABLE WITH LUMBER TOP AND SEATS**

DATE **1-3-17**

DWG. NO. **AI-1817**