



*Model XT/CW-6DA 6 Ft. Extra Heavy Duty Portable Rectangular
Table with brown powder coat frames and
gray thermo-plastic coated D-Type expanded steel seats and top*

- **Frame constructed specifically for heavy use areas**
- **Nontip, nontrip walk-through design**
- **All welded end frames are fabricated from 2-3/8" diameter steel pipe**
- **Diagonal braces align and strengthen entire table**
- **Frames are hot dip galvanized after fabrication for superior corrosion resistance**
- **Thermo-plastic Coating heat fused to Expanded Steel Top and Seats for durability**
- **Thermo-plastic Coating formulated with U.V. stabilizers for ultraviolet protection**
- **Limited lifetime warranty on frames**

AVAILABLE OPTIONS

- **6' or 8' length**
- **Powder Coat Finish in choice of colors for steel frame components**
- **Choice of colors of Thermo-plastic Coating**

SPECIFICATIONS:

- **XT Series** end frames are one-piece welded construction, fabricated from 2.375" O.D. (2-3/8" O.D.) steel pipe to meet 2" nominal steel pipe size specifications with 2" x 2" x 1/8" die formed steel angle for attaching the seats and tops.
- Table frame design incorporates nontip, nontrip, walk-through design features. Bends are tightly formed to prevent tipping when weight is on one side.
- **Model XT/G-6** is a nominal 6 ft. long.
- **Model XT/G-8** is a nominal 8 ft. long.
- Nominal table height is 30". Frame design provides a nominal 28" of clearance from ground level to the underside of table. Nominal seat height is 18".
- Frames are supported by diagonal braces of 1-5/16" O.D. x 14 ga. wall steel pipe that connect to the underside of the table top.
- **Standard:** All steel frame components are hot-dip galvanized after fabrication to ASTM-A123 to maintain an average zinc coating of 2.0 oz. per sq. ft. of surface area (indicated by "/G" in model no., e.g. XT/G-6DW).
- All fasteners are provided for assembly.
- **D-Type** table top and seats are each a one-piece welded construction, fabricated from a 3/4-#9 expanded steel surface with 2" roll-formed 14 ga. steel vertical edges on all sides and reinforced by a strap and die-formed angle substructure.
- **Standard:** All steel surfaces of the top and seats are covered with a thermo-plastic coating in a Brown color (indicated by "DW" in model no., e.g. XT/G-6DW). The UV-stabilized thermo-plastic coating is applied in a multi step process of material preparation and finish application designed to permanently heat fuse and bond the finish to the steel. The thermo-plastic polyethylene finish is impact resistant, does not support mold or mildew, and the textured matte surface is less susceptible to marring and scuffing.
- **Optional:** All steel frame components have powder coat finish. See Specification Bulletin #SPC-CO-001.
- **Optional:** Color choices of Thermo-plastic coated steel components. For optional colors choices see Specification Bulletin #SPC-CO-001.

RJ Thomas Mfg. Co., Inc.

PO Box 946 • Cherokee, IA 51012-0946 • PH: 712-225-5115 • 800-762-5002 • FAX: 712-225-5796
E-mail: pilotrock@rjthomas.com • Web Site: <http://www.pilotrock.com>

© 2017 RJ Thomas Mfg. Co., Inc. PILOT ROCK® Park Products is a registered trademark of RJ Thomas Mfg. Co., Inc.

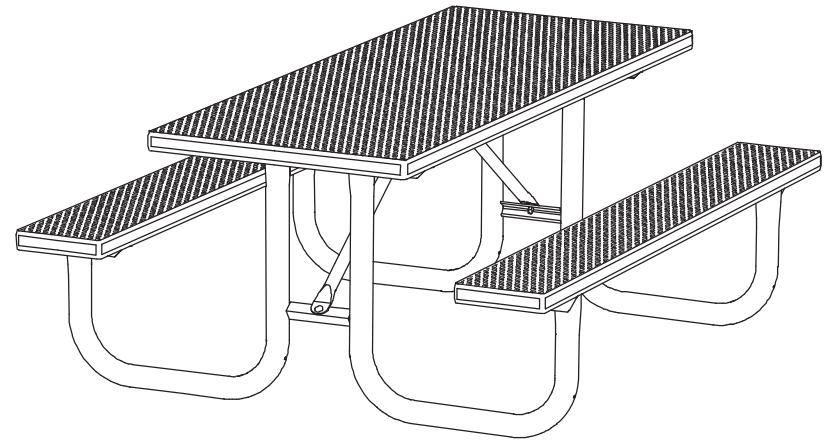
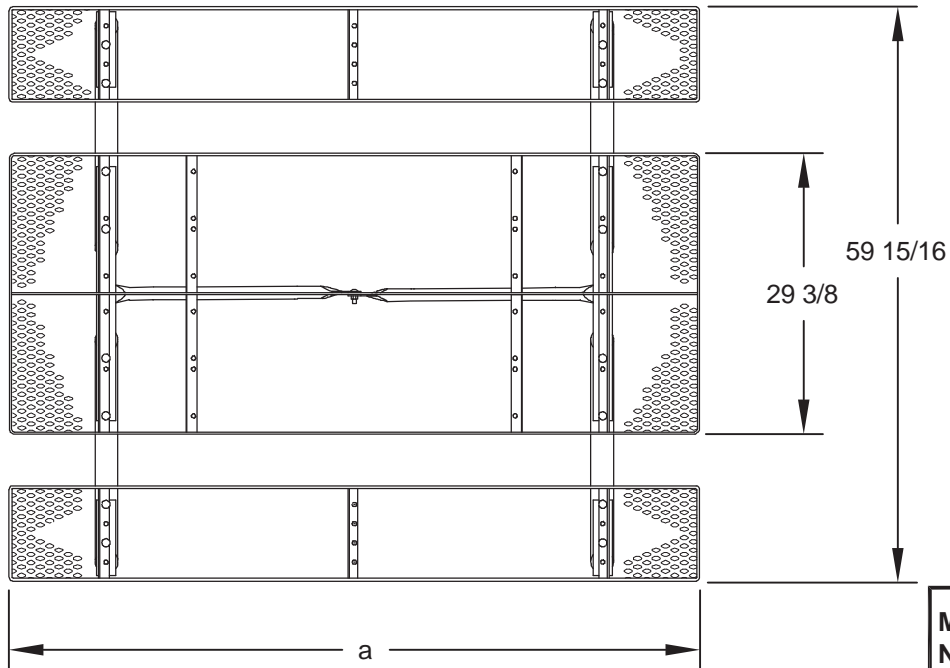

MODEL NUMBER	DIMENSION	
	a	b
XT-6	72	51-3/4
XT-8	96	70

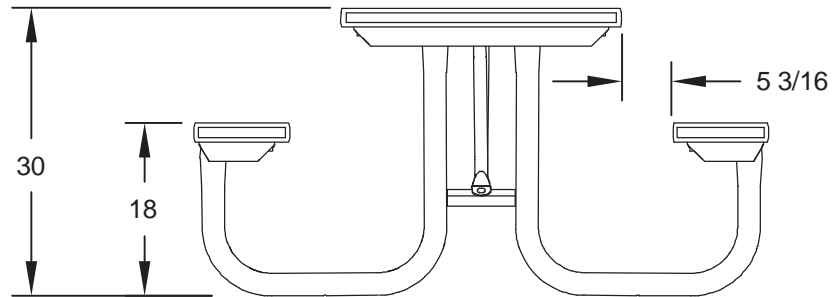
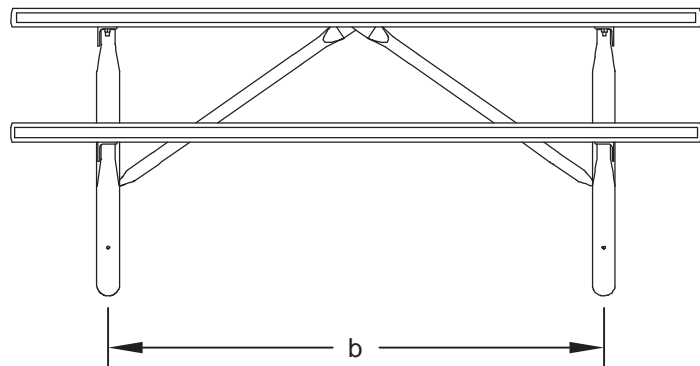

ALL DIMENSIONS IN INCHES

RJThomas Mfg. Co., Inc.
P.O. Box 946 • Cherokee, IA 51012-0946

DRAWN BY
WWM

TITLE **XT SERIES 6 AND 8 FOOT PORTABLE RECTANGULAR TABLE
WITH D-TYPE THERMO-PLASTIC COATED EXPANDED STEEL TOP AND SEATS**

DATE **3-05-10**

DWG. NO. **AI-1675**