

*Model XT/CN-6RW/E 6 Ft. Wheelchair Accessible Table
with green powder coat frames and brown R-Type
thermo-plastic coated perforated steel top and seats*

- **Extended top for wheelchair accessibility at one end**
- **Constructed specifically for heavy use areas**
- **Nontip, nontrip, walk-through design**
- **All welded end frames are fabricated from 2-3/8" diameter steel pipe**
- **Diagonal braces support table extensions**
- **Frames are hot-dip galvanized after fabrication for superior corrosion resistance**
- **Thermo-plastic Coating heat fused to Perforated Steel Top and Seats for durability**
- **Thermo-plastic Coating formulated with U.V. stabilizers for ultraviolet protection**
- **Limited lifetime warranty on frames**

AVAILABLE OPTIONS

- **Powder Coat Finish in choice of colors for steel frame components**
- **Choice of colors of Thermo-plastic Coating**

SPECIFICATIONS:

- **XT Series** end frames are one-piece welded construction, fabricated from 2.375" (2-3/8" O.D.) steel pipe to meet 2" nominal steel pipe size specifications with 2" x 2" x 1/8" die formed steel angle for attaching the seats and tops. "Outriggers" are attached to the frame on the extended end of the table for added stability.
- Table top extends 2 ft. beyond seats (indicated by "/E" in model no., e.g. XT/G-6RW/E) to provide the ADA recommended wheelchair clearances of: 30" wide, 27" under table (ground to bottom of table top), and 24" total knee and toe clearance (19" + 5").
- A diagonal brace of 1-5/16" O.D. steel pipe is provided to support extended portions of table top.
- **Model XT/G-6RW/E** has a nom. 8 ft. long top and 6 ft. long seats. Includes frame stabilizing outriggers.
- Frames are supported by diagonal braces of 1-5/16" O.D. steel pipe.
- Table height provides a nominal 28" of clearance from ground level to the underside of the table top. Nominal seat height is 18-1/2".
- **Standard:** All steel frame components are hot-dip galvanized after fabrication to ASTM-A123 to maintain an average zinc coating of 2.0 oz. per sq. ft. of surface area (indicated by "/G" in model no., e.g. XT/G-6RW/E).
- All fasteners are provided for assembly.
- **R-Type** table top (14 ga.) and seats (12 ga.) are each one-piece welded construction, fabricated from perforated steel, with 9/16" dia. holes in a 13/16" center to center in-line pattern, and 2" formed vertical edges on all sides and reinforced by a strap and angle substructure.
- **Standard:** All steel surfaces of the top and seats are covered with a thermo-plastic coating in a Brown color (indicated by "RW" in model no., e.g. XT/G-6RW/E). The UV-stabilized thermo-plastic coating is applied in a multi step process of material preparation and finish application designed to permanently heat fuse and bond the finish to the steel. The thermo-plastic polyethylene finish is impact resistant, does not support mold or mildew, and the textured matte surface is less susceptible to marring and scuffing.
- **Optional:** All steel frame components have powder coat finish. See Specification Bulletin #SPC-CO-001.
- **Optional:** Color choices of Thermo-plastic coated steel components. For optional colors choices see Specification Bulletin #SPC-CO-001.

RJ Thomas Mfg. Co., Inc.

PO Box 946 • Cherokee, IA 51012-0946 • PH: 712-225-5115 • 800-762-5002 • FAX: 712-225-5796
E-mail: pilotrock@rjthomas.com • Web Site: <http://www.pilotrock.com>

© 2019 RJ Thomas Mfg. Co., Inc. PILOT ROCK® Park Products is a registered trademark of RJ Thomas Mfg. Co., Inc.

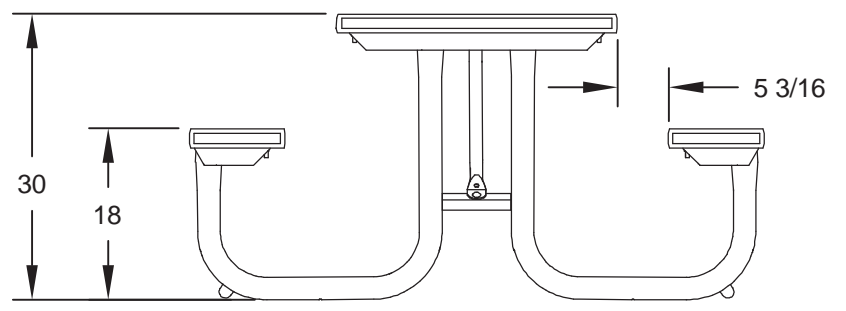
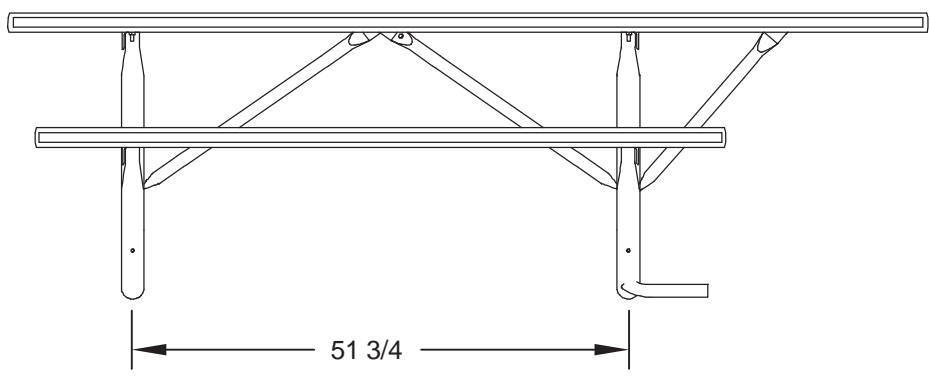
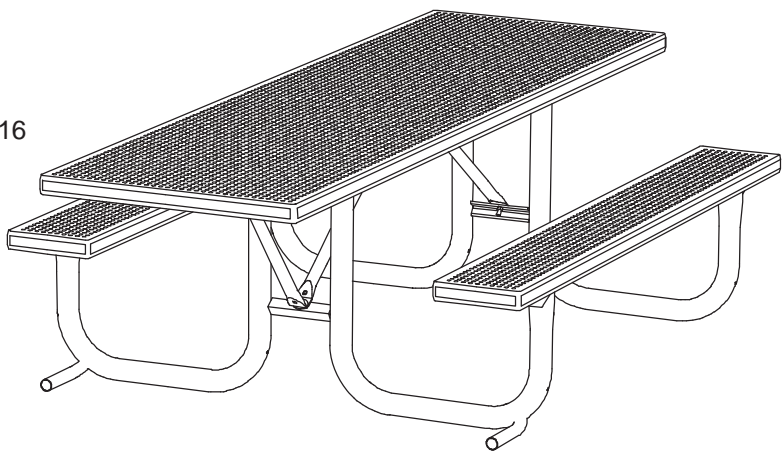
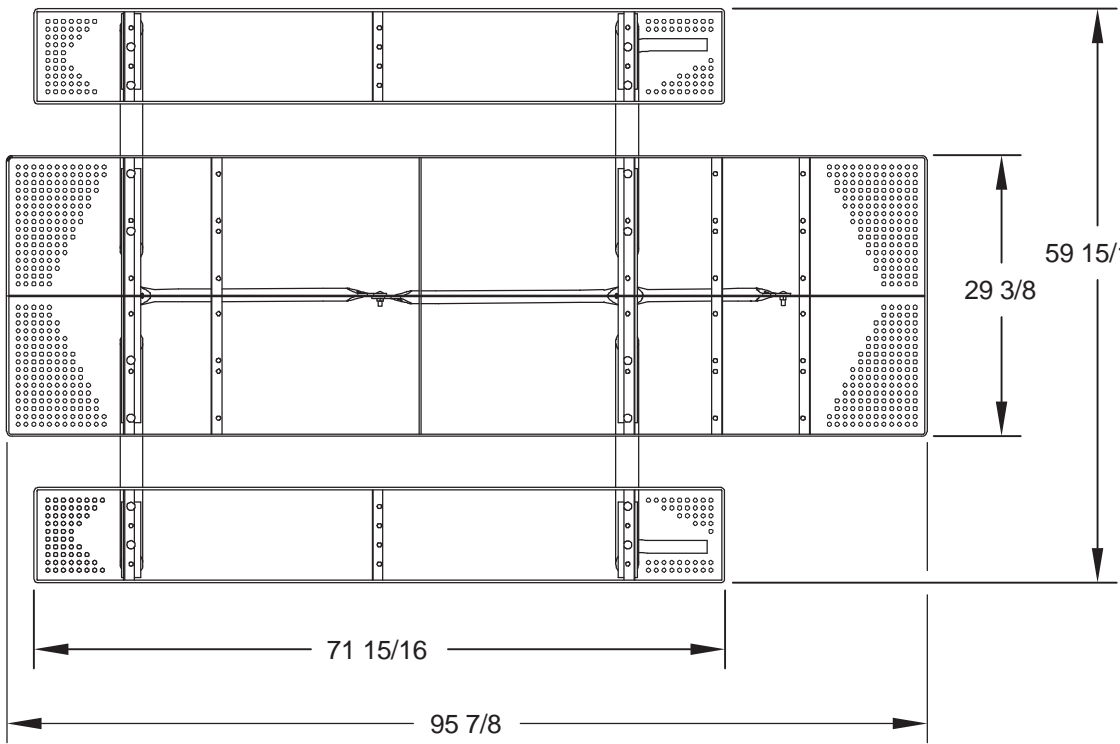

ALL DIMENSIONS IN INCHES

RJThomas Mfg. Co., Inc.
 P.O. Box 946 • Cherokee, IA 51012-0946

DRAWN BY
WWM

TITLE **XT SERIES 6 FOOT WHEELCHAIR ACCESSIBLE PORTABLE RECTANGULAR TABLE
 EXTENDED ON ONE END WITH R-TYPE THERMO-PLASTIC COATED
 PERFORATED STEEL TOP AND SEATS**

DATE **3-05-10**
 DWG. NO. **AI-1693**