



Model AFT-6TP 6 ft. All Lumber A-Frame Rectangular Table with treated pine legs and treated pine top and seat planks

- **Traditional A-Frame design**
- **Sturdy 4" x 6" treated #1 Southern Yellow Pine legs**
- **2" x 10" treated #1 Southern Yellow Pine top and seat planks**
- **Quality construction throughout**

SPECIFICATIONS:

- **AFT Series** end frames are constructed from two 4" x 6" nominal sized timbers forming the legs of the "A" with ends cut at angles to provide firm contact with ground surface. Legs are connected at top by a 2" x 4" timber which also provides attachment of table top planks. A 2" x 6" timber connects legs at seat height and extends beyond legs to provide mounting and support for seat planks.
- Table is supported by diagonal braces of 2" x 4" lumber that connect to a 2" x 4" center top support designed to align and provide attachment to the table top. Six foot model has two braces between legs, eight foot model has two braces between legs and one on each end to support the top.
- **Model AFT-6TP** shall have a nominal length of 72".
- **Model AFT-8TP** shall have a nominal length of 96".
- Nominal table height is 30-1/4", seat height is 17-3/4".
- All fasteners are provided for assembly.
- **Standard:** Legs are 4" x 6" nominal sized Treated #1 grade Southern Yellow Pine. Top and seat planks are 2" x 10" nominal sized Treated #1 grade Southern Yellow Pine planks, kiln dried to reduce moisture content. All lumber is precision drilled to facilitate assembly and has all exposed edges removed to a 3/8" radius.
- Seat planks are supported by 2" x 6" timbers on edge under the seat planks.
- **Wheelchair Access:** Table top on eight foot model extends beyond frame on each end to provide the ADA recommended wheelchair clearances of: 30" wide, 27" under table (ground to bottom of table top), and 24" total knee and toe clearance (19" + 5") at both ends.

AVAILABLE OPTIONS

6' and 8' lengths

RJ Thomas Mfg. Co., Inc.

PO Box 946 • Cherokee, IA 51012-0946 • PH: 712-225-5115 • 800-762-5002 • FAX: 712-225-5796
E-mail: pilotrock@rjthomas.com • Web Site: <http://www.pilotrock.com>

© 2008 RJ Thomas Mfg. Co., Inc. PILOT ROCK[®] Park Products is a registered trademark of RJ Thomas Mfg. Co., Inc.

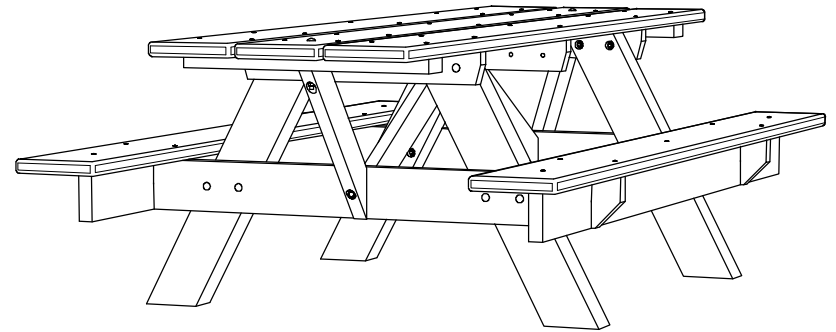
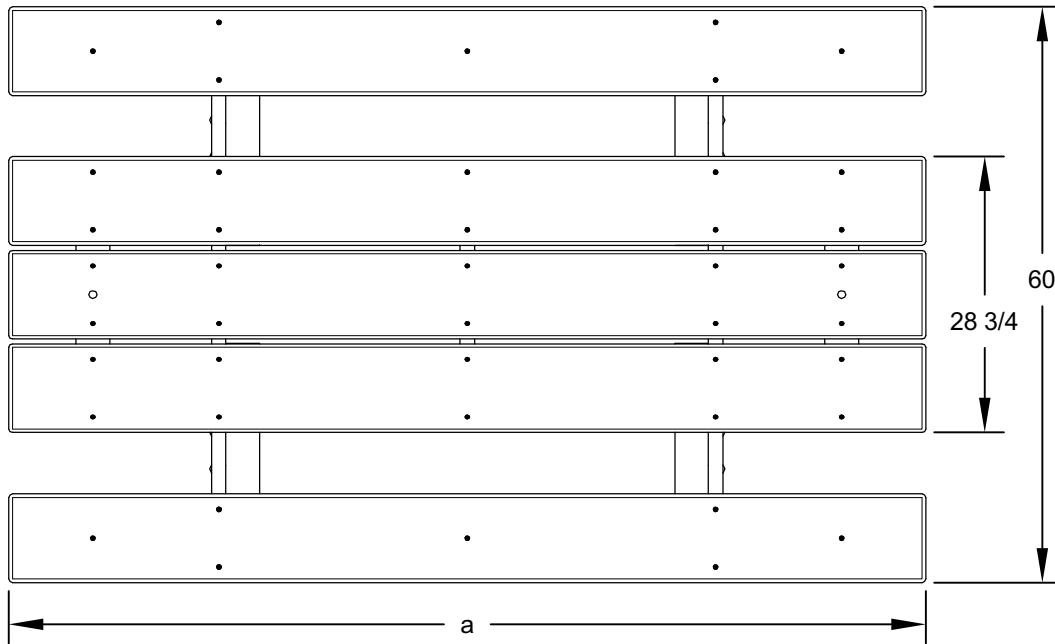

	DIMENSION
MODEL	a
AFT-6	71 1/2
AFT-8	95 1/2

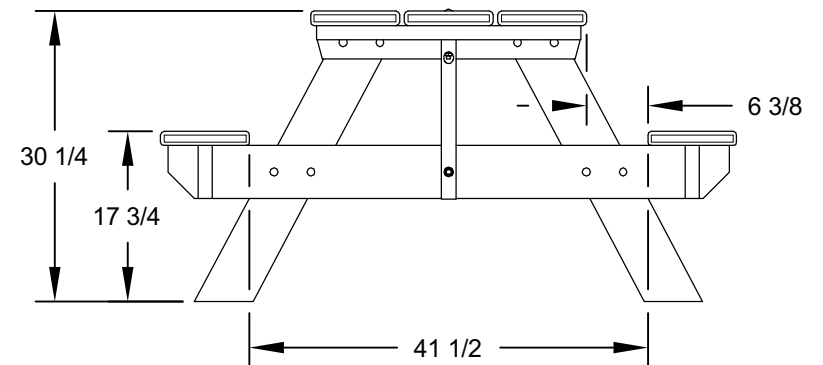
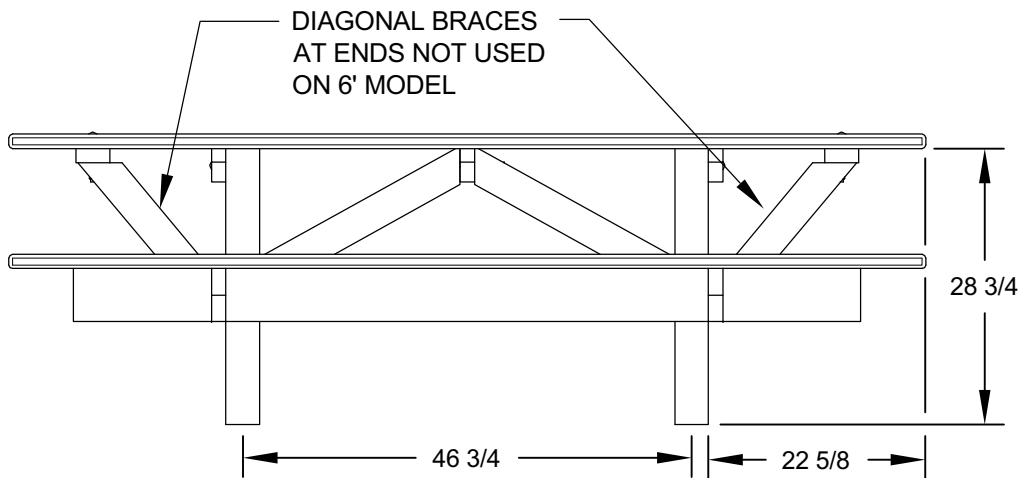

ALL DIMENSIONS IN INCHES

RJThomas Mfg. Co., Inc.
P.O. Box 946 • Cherokee, IA 51012-0946

DRAWN BY
WWM

TITLE AFT SERIES 6 AND 8 FOOT PORTABLE ALL LUMBER A-FRAME TABLE

DATE 1-18-11

DWG. NO. **AI-1979**