



*Model APB/CB-6AL Embedded Mount Bench
with black powder coated frames, 6 Ft. long
with clear anodized aluminum seat.*

- **Sturdy bench for permanent locations**
- **Frames are hot dip galvanized after fabrication for superior corrosion resistance**
- **Structurally reinforced extruded Aluminum Seats with clear anodized finish**
- **Quality construction throughout**

SPECIFICATIONS:

- **Model APB** seat frames are one-piece welded construction, fabricated from 3" x 6" x 1/8" wall rectangular structural steel tubing with 2" x 2" x 3/16" A-36 structural grade steel angle for attaching the seat material. Exposed ends of rectangular tubing are permanently sealed with welded-on steel end caps. Legs are designed to be embedded in concrete footings.
- **Model APB-4** is a nom. 4 ft. in length.
- **Model APB-6** is a nom. 6 ft. in length.
- **Model APB-8** is a nom. 8 ft. in length.
- Nominal seat height is 18".
- **Standard:** Frames are hot-dip galvanized after fabrication to ASTM-A123 to maintain an average zinc coating of 2.0 oz. per sq. ft. of surface area (indicated by "/G" in model no., e.g. APB/G-6AL).
- Aluminum is extruded 6063-T6 aluminum alloy in planks with dimensions equivalent to that of 2" x 10" nominal sized lumber. The plank design is 1-3/4" x 9-5/8" with four structural reinforcement ribs for greater rigidity. Aluminum planks are provided with a clear anodized finish as per anodizing specification 204 R1. Aluminum clips to fasten planks to frames are included.
- Channel end caps are of extruded 6063-T6 aluminum alloy provided with a clear anodized finish as per anodizing specification 204 R1. End caps are press fitted over ends of aluminum planks and mechanically fastened in place at the factory.
- Aluminum planks are provided with galvanized carriage bolts, nuts, and precision fitted aluminum brackets to fasten planks to bench frames.
- All fasteners are provided for assembly.
- **Optional:** Color choices of powder coated steel frame components. For optional colors choices see Specification Bulletin #SPC-CO-001.
- **Optional:** Color choices of thermo-plastic coated steel components. For optional colors choices see Specification Bulletin #SPC-CO-001.
- **Optional:** Frames have a 1/4" x 8" x 8" steel base plate with four 25/32" dia. holes to bolt bench to concrete pad. To specify add "/P" after the "APB" in the model no., e.g. APB/P/G-6AL. (Anchor bolts not included.)

AVAILABLE OPTIONS

- **4', 6' or 8' models**
- **Powder Coat Finish in choice of colors for steel frame components**
- **Powder Coat Finish in choice of colors for Aluminum seat**
- **Base plate for surface mounting**

RJ Thomas Mfg. Co., Inc.

PO Box 946 • Cherokee, IA 51012-0946 • PH: 712-225-5115 • 800-762-5002 • FAX: 712-225-5796
E-mail: pilotrock@rjthomas.com • Web Site: <https://www.pilotrock.com>

© 2023 RJ Thomas Mfg. Co., Inc. PILOT ROCK® Park Products is a registered trademark of RJ Thomas Mfg. Co., Inc.

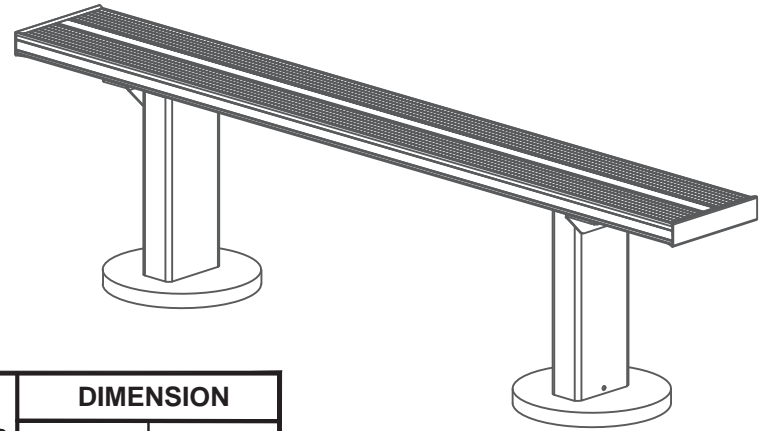
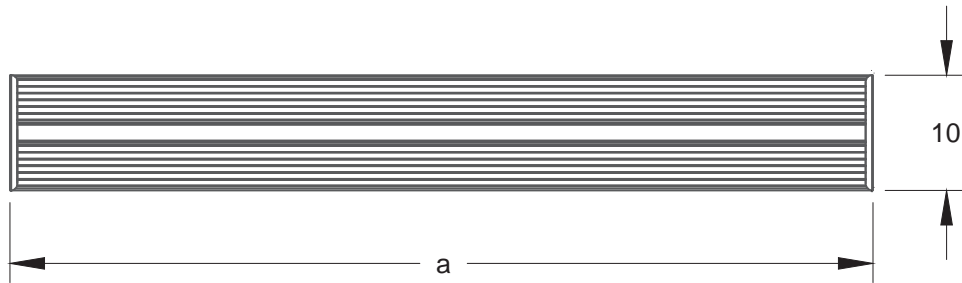

MODEL NUMBER	DIMENSION	
	a	b
APB-4	48	29
APB-6	72	44-3/4
APB-8	96	77

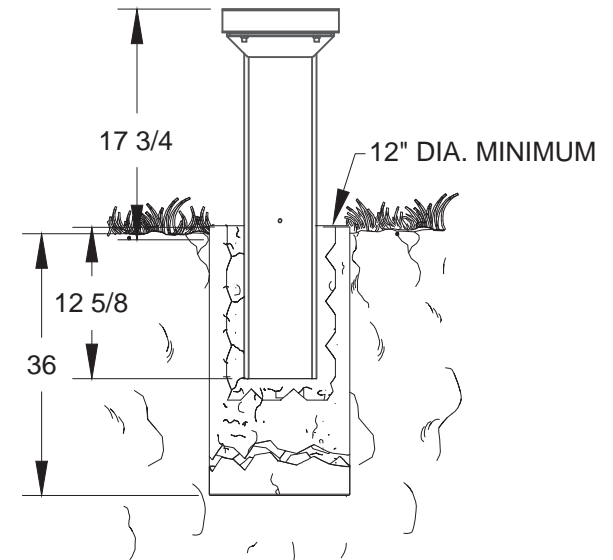
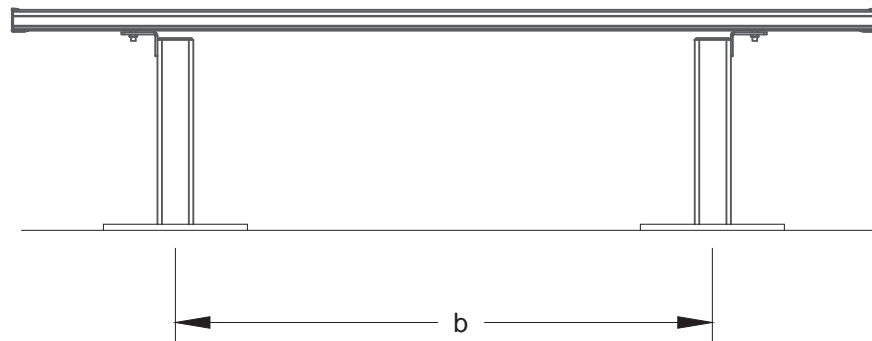

NOTE:
 LOCAL SOIL
 CONDITIONS
 MAY REQUIRE
 A LARGER
 FOOTING
 (CHECK LOCAL
 CODES)

ALL DIMENSIONS IN INCHES

RJThomas Mfg. Co., Inc.
 P.O. Box 946 • Cherokee, IA 51012-0946

DRAWN BY
JGJ

TITLE MODEL APB 4, 6 AND 8 FOOT EMBEDDED MOUNT DOUBLE PEDESTAL
 BENCH WITH 10" WIDE ALUMINUM SEAT

DATE 01-17-23

DWG. NO. AI-3041