

Grey Creek Series, Model B31 Embedded Mount 4 and 6 Ft. Bench with Lumber Timbers



*Model B31/CB-6CO34 6 Ft. Embedded Mount Bench
with Black Powder Coat Frames
and Construction Heart Redwood 3" x 4" Timbers.*

- **Comfortable seat design may be accessed from either side**
- **Wide, comfortable armrest loops integrated into end frames**
- **Sturdy, formed and welded steel frame construction**
- **Powder Coat or Hot Dip Galvanized frame finish**
- **Precision drilled Hardwood 3" x 4" Timbers**
- **Quality construction throughout**

SPECIFICATIONS:

- **Model B31 Series** end frames are one-piece welded construction with 3/8" x 2-1/2" A-36 flat steel bar legs. Seat brackets are constructed of 3/8" x 2-1/2" A-36 flat steel bar with holes to mount four 3" x 4" timbers. The end frames include a welded-on circular armrest formed from 1/4" x 2-1/2" A-36 flat steel bar.
- **Model B31-4** is a nom. 4 ft. in length.
- **Model B31-6** is a nom. 6 ft. in length.
- Benches are designed to be permanently anchored by embedding bench legs in concrete footings.
- **Standard:** Frame are finished in Black powder coat (indicated by "/CB" in model no., e.g. B31/**CB**-4CO34).
- **Standard:** Lumber is Construction Heart Redwood 3" x 4" nominal sized timbers (indicated by "CO" in model no., e.g. B31/**CB**-4**CO**34). All timbers are precision drilled for assembly and have all exposed edges removed to a 3/8" radius with a bullnose profile timber used on outside positions.
- All fasteners are provided for assembly.
- **Optional:** Color choices of powder coated steel frame components. For optional colors choices see Specification Bulletin #SPC-CO-001.
- **Optional:** Frames are hot-dip galvanized after fabrication to ASTM-A123 to maintain an average zinc coating of 2.0 oz. per sq. ft. of surface area. (To specify, change "/CB" in model no. to "/G", e.g. B31/**G**-4CO34).

AVAILABLE OPTIONS

- 4' or 6' models
- Powder Coat Finish in choice of colors or Hot Dip Galvanized steel frame components
- Custom Plaques available (call for details)

RJ Thomas Mfg. Co., Inc.

PO Box 946 • Cherokee, IA 51012-0946 • PH: 712-225-5115 • 800-762-5002 • FAX: 712-225-5796
E-mail: pilotrock@rjthomas.com • Web Site: <https://www.pilotrock.com>

© 2022 RJ Thomas Mfg. Co., Inc. PILOT ROCK® Park Products is a registered trademark of RJ Thomas Mfg. Co., Inc.

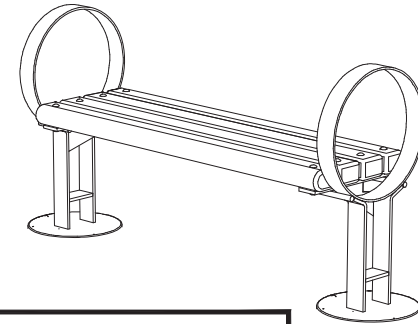
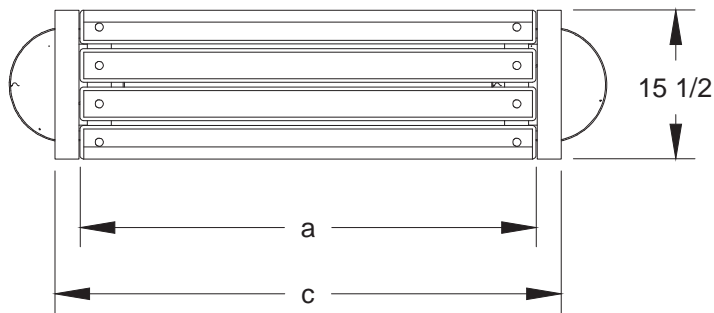

| MODEL NUMBER | DIMENSION | | |
|--------------|-----------|--------|--------|
| | a | b | c |
| B31-4 | 47 1/2 | 50 1/4 | 52 3/4 |
| B31-6 | 71 1/2 | 74 1/4 | 76 3/4 |

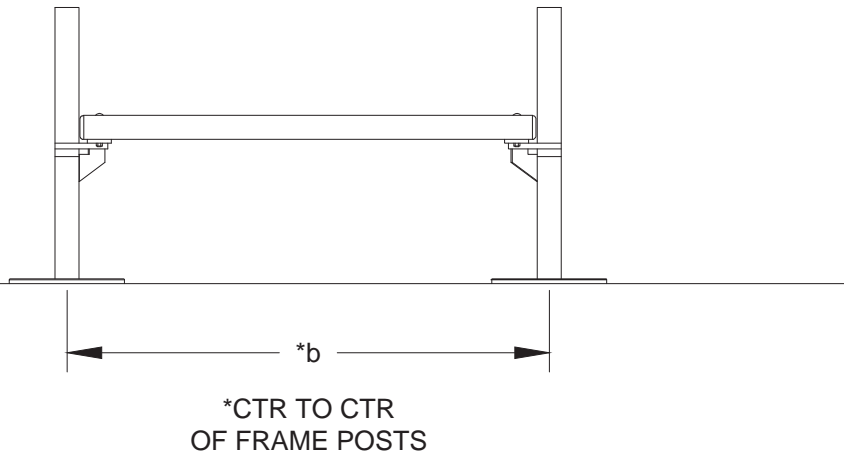

ALL DIMENSIONS IN INCHES

ALL DIMENSIONS IN INCHES

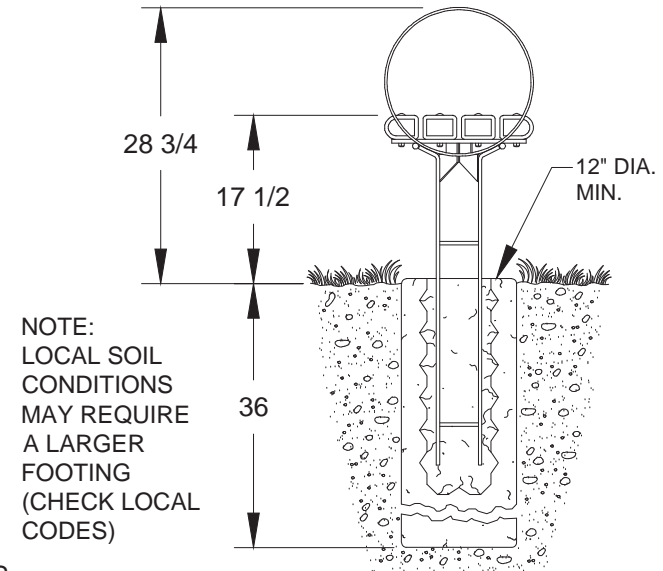

NOTE:
LOCAL SOIL
CONDITIONS
MAY REQUIRE
A LARGER
FOOTING
(CHECK LOCAL
CODES)

RJThomas Mfg. Co., Inc.
P.O. Box 946 • Cherokee, IA 51012-0946

DRAWN BY
WWM

TITLE **GREY CREEK SERIES MODEL B31 4 AND 6 FOOT FLAT EMBEDDED MOUNT
BENCHES WITH 3" x 4" LUMBER TIMBERS**

DATE 06-07-21

DWG. NO. **AI-1567**