



*Model FSW/SL-30/18/PA Wheelchair Accessible
Campfire Ring with snow load rated swivel cooking grate.*

(Below) Grate shown rotated out of the firering.



- **Cooking grate withstands snow loads of over 569 lbs./sq. ft.**
- **Meets ADA guidelines, requires less than five pounds of force with one hand to move grate out of firering**
- **Handle is never over the fire**
- **Flanged firering for strength and safety**
- **Public use-type spring grips of coiled steel bar**
- **Elevated cooking grate and firebed conform to ADA guidelines**
- **Required aggregate fill protects site surfaces such as paver blocks, cement, and asphalt from heat damage**

AVAILABLE OPTIONS

Utility Shelf
Heat Shield

SPECIFICATIONS:

- Our new Swivel Grate firering design is tested to withstand snow loads of over **569 lbs. per sq. ft.** on the grate. The swivel grate is laser cut from 1/4-inch thick steel plate. A special 10 ga. channel brace is welded inside the ring to reinforce the swivel tube.
 - 32" overall dia. firering is constructed from 3/16" thick steel with a formed (NOT WELDED) 1" flanged lip around the top of the ring and ten 1" dia. drain/draft/anchor holes located around the perimeter.
 - **Model FSW/SL-30/18/PA** firering side height is 16-7/8".
 - **Model FSW/SL-30/24/PA** firering side height is 23-3/8".
 - The Swivel Grate design meets the ADA guidelines for one hand operation and requires less than 5 lbs. of force to move. The 300 sq. in. single level grate will move 180° – from over the fire to completely out of the fire ring – for easy fire building and serving. The handle is never over the fire.
 - Grate is provided with a substantially constructed spring grip suitable for public use made from 1/8" x 1/2" flat bar (not wire springs).
 - Grate is mounted on a 2-3/8" OD tube allowing it to rotate on a horizontal plane out of the firering. Two welded-on stops limit rotation to 180° to prevent the handle entering the area over the fire.
 - Firering is designed to be filled with customer supplied aggregate fill to a minimum of 9" above ground level to conform with ADA guidelines to raise fire to proper height. Fill also protects hard surfaces from heat damage.
 - Unit is provided with three 1/2" dia. anchor pins for concrete embedment (indicated by **"/PA"** in model no., e.g. FSW/SL-30/18/PA).
 - Entire unit is finished in high temperature, heat resistant, nontoxic black enamel paint.
 - **Optional:** Firering is provided with a 3/16" x 7-1/8" x 9-5/8" steel plate utility shelf. (Add **"/S"** to model no., e.g. FSW/SL-30/18/PA/S.)
 - **Optional:** Firering is provided with an 8" high heat shield constructed from 10 ga. steel welded on to new firerings. Heat shield provides a 7/8" cooling air gap around the area of the firering exposed to the fire (indicated by **"/H"** in model no., e.g. FSW/SL-30/18/PA/H).
- Note:** The optional utility shelf fits both firering and optional heat shield. (When ordering both options, add **"/H/S"** to model no., e.g. FSW-30/18/PA/H/S.)

RJ Thomas Mfg. Co., Inc.

PO Box 946 • Cherokee, IA 51012-0946 • PH: 712-225-5115 • 800-762-5002 • FAX: 712-225-5796
E-mail: pilotrock@rjthomas.com • Web Site: <https://www.pilotrock.com>

© 2020 RJ Thomas Mfg. Co., Inc. PILOT ROCK® Park Products is a registered trademark of RJ Thomas Mfg. Co., Inc.

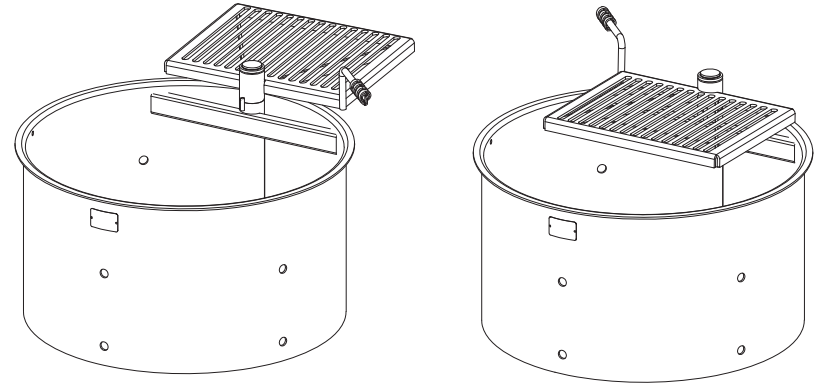
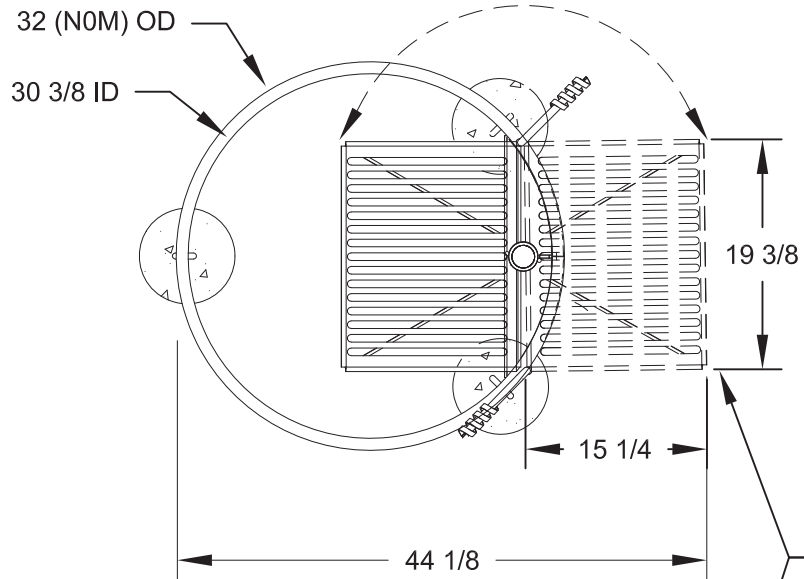

GRATE ROTATES
180 DEGREES
TO OUTSIDE FIRERING

MODEL NUMBER	DIMENSION		
	a	b	c
FSW/SL-30/18	23 1/4	16 7/8	19 5/8
FSW/SL-30/24	29 3/4	23 3/8	26 1/8

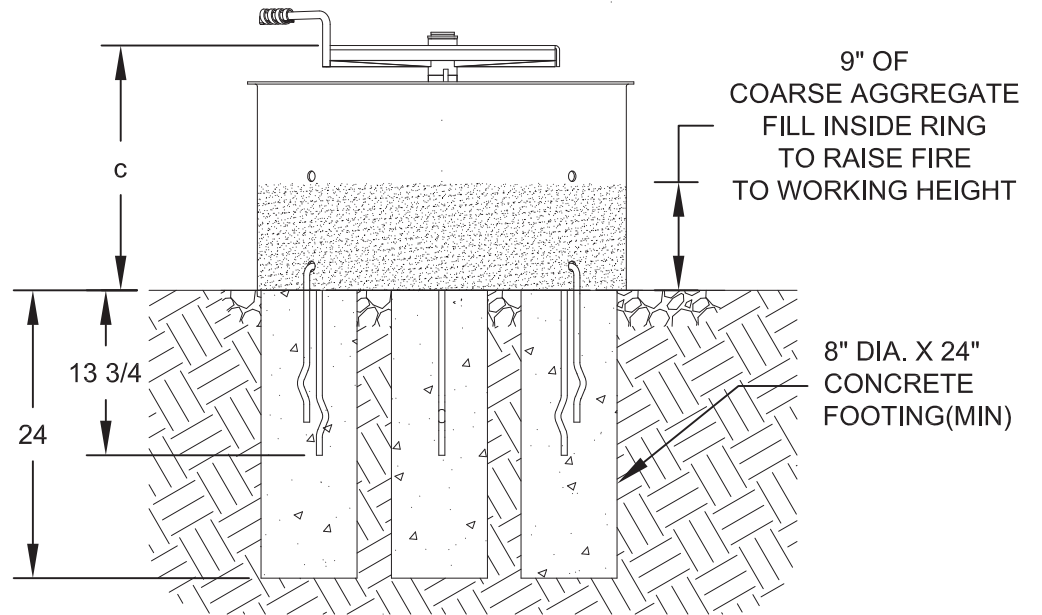
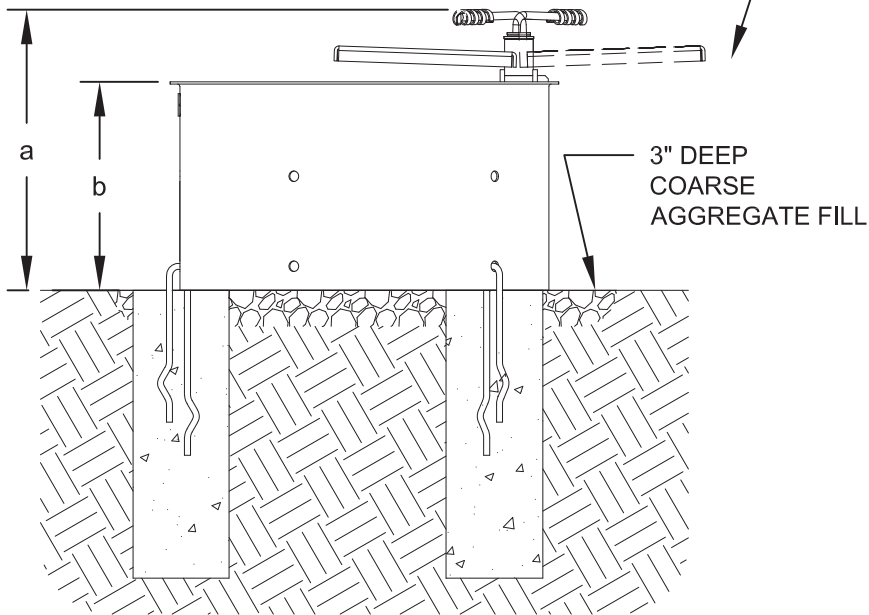

ALL DIMENSIONS IN INCHES

RJThomas Mfg. Co., Inc.
P.O. Box 946 • Cherokee, IA 51012-0946

DRAWN BY
JGJ

TITLE FSW/SL SERIES MODELS FSW/SL-30/18/PA AND FSW/SL-30/24/PA ACCESSIBLE
FIRERING WITH SNOW LOAD RATED SWIVEL GRATE AND PIN ANCHORS

DATE 05-06-2020

DWG. NO. **AI-3015**