



*Model SQT/B-4UP 5 Plank, 48" Square Top,
Portable Square Table with Hot Dip Galvanized Frame
and Untreated Southern Yellow Pine Planks*

- **Square design optimizes table top usage and creates a more intimate setting**
- **Square table fits into more compact areas**
- **Nontip, nontrip, walk-through design**
- **All welded corner frames are fabricated from 1-1/2" diameter steel pipe**
- **Cross braces square up the corner frames and strengthen the table**
- **Precision drilled, Untreated #1 Southern Yellow Pine Seat and Top Planks**
- **Quality construction throughout**

SPECIFICATIONS:

- **Model SQT-3** has a nominal 38" square table top utilizing (4) top planks.
- **Model SQT-4** has a nominal 48" square table top utilizing (5) top planks.
- Table frame design incorporates nontip, nontrip, walk-through features. Bends are tightly formed to prevent tipping when weight is on one side.
- Four SQT Series corner frames are each of one-piece welded construction made from 1-1/2" dia. x 1/8" wall structural steel tubing and seat supports of 1-3/4" x 1-3/4" x 1/8" die formed steel angle.
- Nominal table height is 30". Nominal seat height are 18".
- Top planks are supported and attached to corner frames by two 1-3/4" x 1-3/4" x 1/8" die formed steel angles.
- Corner frames are connected by two cross braces constructed of 1-5/16" O.D. steel pipe.
- All fasteners are provided for table assembly.
- **Standard:** All steel frame components are hot-dip galvanized after fabrication to ASTM-A123 to maintain an average zinc coating of 2.0 oz. per sq. ft. of surface area (indicated by "/G" following the SQT in model no., e.g. SQT/G-3UP).
- **Standard:** Lumber is Untreated #1 grade Southern Yellow Pine (indicated by "UP" in model no., e.g. SQT/G-3UP) 2" x 10" nominal sized planks, kiln dried to reduce moisture content. All lumber is precision drilled to facilitate assembly and has all exposed edges removed to a 3/8" radius.
- **Optional:** Treated #1 Southern Yellow Pine is readily available and is pressure treated (KDAT) to preserve wood against decay. To specify, change "UP" in model no. to "TP", e.g. SQT/G-4TP. (Cedar, Fir and Redwood are available when in stock -please inquire.)
- **Optional:** Color choices of powder coated steel frame components. For optional colors choices see Specification Bulletin #SPC-CO-001.
- **Optional:** Table is provided with backrests. To specify, add "/B" to end of model no., e.g. SQT/G-4UP/B.
- **Optional:** Table is provided with umbrella holes in table tops and cup and collar sets for mounting umbrellas. To specify, add "/U" to the end of the model no., e.g. SQT/G-4UP/U.

AVAILABLE OPTIONS

- 3' or 4' square models
- Powder Coat Finish in choice of colors for steel frame components
- Pressure treated #1 Southern Yellow Pine lumber (Cedar, Fir, or Redwood lumber when in stock)
- Backrest attachments
- Umbrella

RJ Thomas Mfg. Co., Inc.

PO Box 946 • Cherokee, IA 51012-0946 • PH: 712-225-5115 • 800-762-5002 • FAX: 712-225-5796
E-mail: pilotrock@rjthomas.com • Web Site: <http://www.pilotrock.com>

© 2017 RJ Thomas Mfg. Co., Inc. PILOT ROCK® Park Products is a registered trademark of RJ Thomas Mfg. Co., Inc.

**NOTE: SQT-3 TABLES HAVE (4) TOP PLANKS
SQT-4 TABLES HAVE (5) TOP PLANKS**

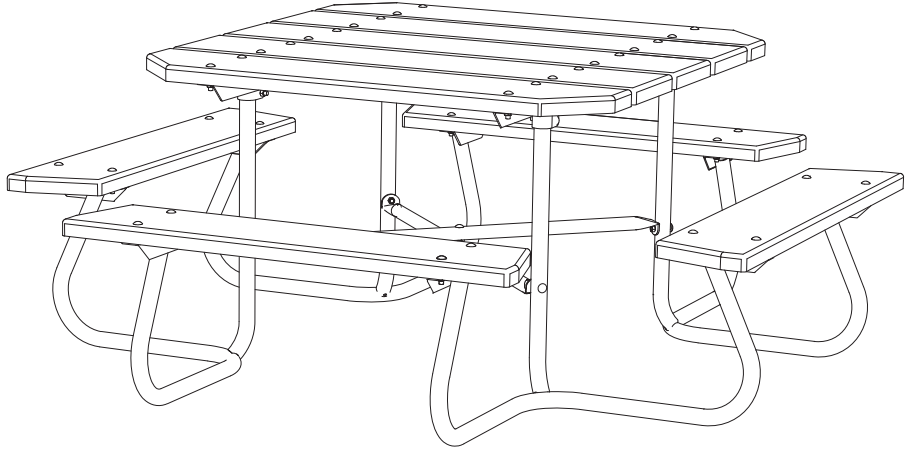
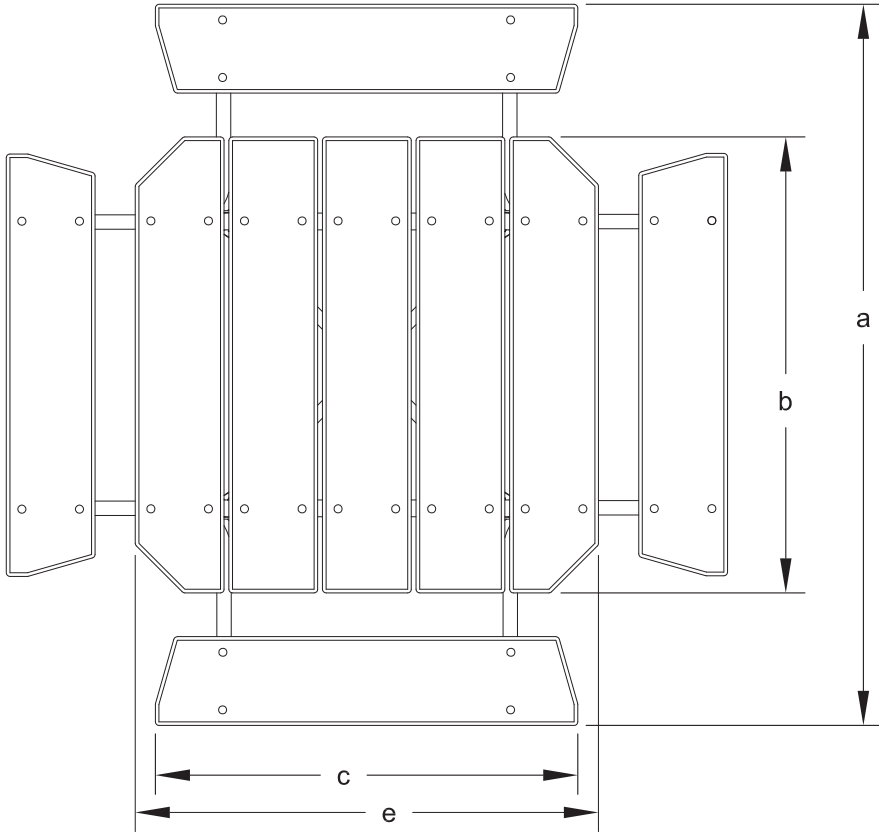

MODEL NUMBER	DIMENSION				
	a	b	c	d	e
SQT-3	65 1/8	38	33 3/8	4 1/16	38 1/2
SQT-4	75 1/8	47 1/2	44	4 3/16	48 1/4

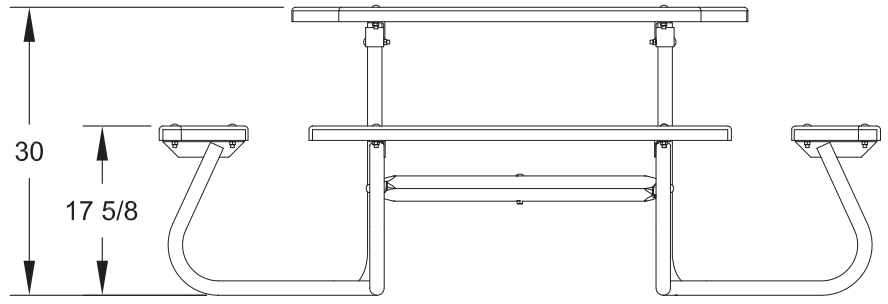
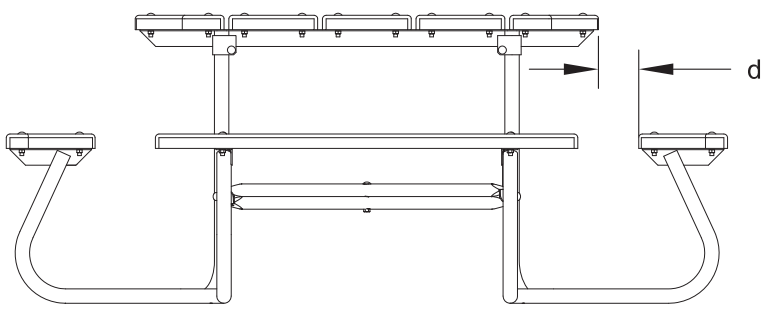

ALL DIMENSIONS IN INCHES

RJThomas Mfg. Co., Inc.
P.O. Box 946 • Cherokee, IA 51012-0946

DRAWN BY
WWM

TITLE **SQT SERIES 3 AND 4 FOOT PORTABLE SQUARE TABLES WITH LUMBER TOP AND SEAT PLANKS**

DATE 11-05-08

DWG. NO. **AI-1496**