



*Model SQT/CB-4VU 48" Portable Square Table
with black powder coat frames
and blue V-Type thermo-plastic coated expanded steel seats and top*

- **Square design optimizes table top usage and creates a more intimate setting**
- **Square table fits into more compact areas**
- **Nontip, nontrip, walk-through design**
- **All welded corner frames are fabricated from 1-1/2" diameter steel pipe**
- **Cross braces square up the corner frames and strengthen the table**
- **Thermo-plastic Coating heat fused to Expanded Steel Top and Seats for durability**
- **Thermo-plastic Coating formulated with U.V. stabilizers for ultraviolet protection**
- **Quality construction throughout**

AVAILABLE OPTIONS

- Powder Coat Finish in choice of colors for steel frame components**
- Choice of colors of Thermo-plastic Coating**
- Umbrella**

SPECIFICATIONS:

- **Model SQT-4** has a nominal 48" square table top.
- Table frame design incorporates nontip, nontrip, walk-through features. Bends are tightly formed to prevent tipping when weight is on one side.
- Four SQT Series corner frames are each a one-piece welded construction made from 1-1/2" dia. x 1/8" wall structural steel tubing and seat supports of 1-3/4" x 1-3/4" x 1/8" die formed steel angle.
- Nominal table height is 30-1/2". Nominal seat height is 18-1/16".
- Top is supported and attached to corner frames by two 1-3/4" x 1-3/4" x 1/8" die formed steel angles.
- Corner frames are connected by two cross braces constructed of 1-5/16" O.D. steel pipe.
- Table top and seats are one-piece welded construction, fabricated from 3/4-#9 expanded steel welded to 1/8" x 2" formed steel edge bands and reinforced by 1/8" steel bars and 1-1/4" x 1/8" angle.
- All fasteners are provided for assembly.
- **Standard:** All steel frame components are hot-dip galvanized after fabrication to ASTM-A123 to maintain an average zinc coating of 2.0 oz. per sq. ft. of surface area (indicated by "/G" following the SQT in model no., e.g. SQT/G-4VW).
- **Standard:** All steel surfaces of the top and seats are covered with a thermo-plastic coating in a Brown color (indicated by "VW" in model no., e.g. SQT/G-4VW). The UV-stabilized thermo-plastic coating is applied in a multi step process of material preparation and finish application designed to permanently heat fuse and bond the finish to the steel. The thermo-plastic polyethylene finish is impact resistant, does not support mold or mildew, and the textured matte surface is less susceptible to marring and scuffing.
- **Standard:** Table is provided with umbrella cup for mounting optional umbrella.
- **Optional:** Table is provided with four 45" long thermo-plastic coated contoured bench seats constructed of steel frame and expanded steel seat. To specify, add "B" after "SQT" in the model no., e.g. SQT/B/G-4HW.
- **Optional:** Color choices of powder coated steel frame components. For optional colors choices see Specification Bulletin #SPC-CO-001.
- **Optional:** Color choices of Thermo-plastic coated steel components. For optional colors choices see Specification Bulletin #SPC-CO-001.

RJ Thomas Mfg. Co., Inc.

PO Box 946 • Cherokee, IA 51012-0946 • PH: 712-225-5115 • 800-762-5002 • FAX: 712-225-5796
E-mail: pilotrock@rjthomas.com • Web Site: <http://www.pilotrock.com>

© 2017 RJ Thomas Mfg. Co., Inc. PILOT ROCK® Park Products is a registered trademark of RJ Thomas Mfg. Co., Inc.

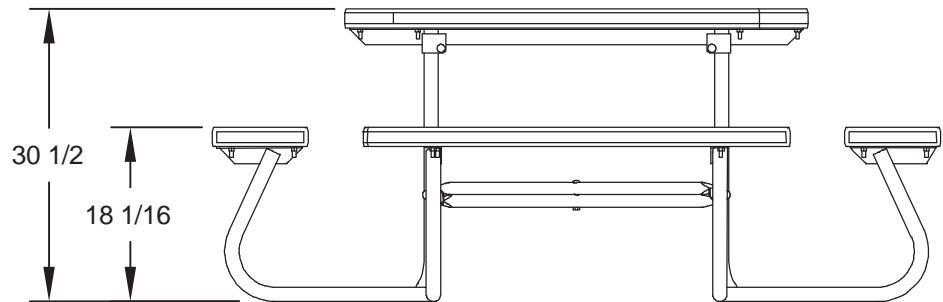
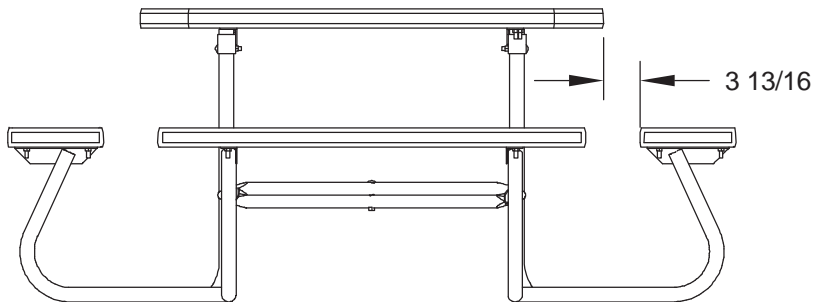
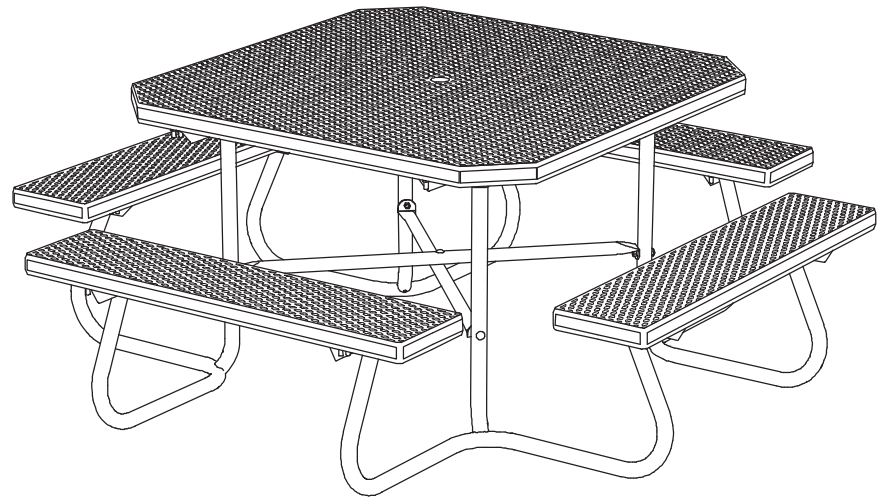
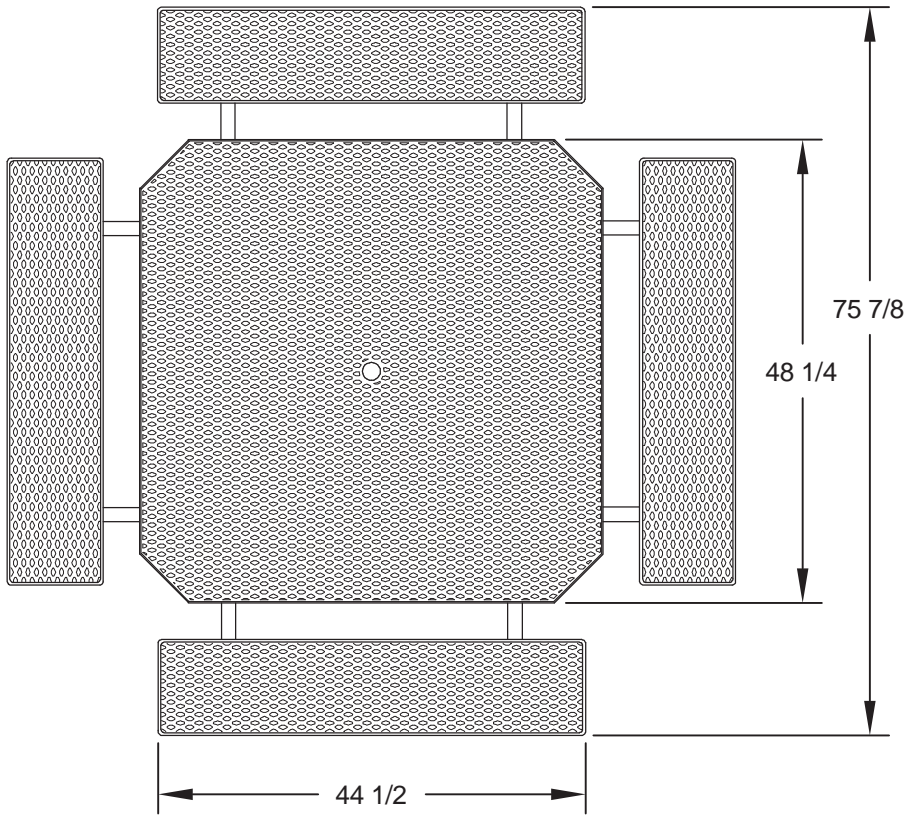

ALL DIMENSIONS IN INCHES

RJThomas Mfg. Co., Inc.
P.O. Box 946 • Cherokee, IA 51012-0946

DRAWN BY
WWM

TITLE **SQT SERIES 4 FOOT PORTABLE SQUARE TABLES WITH V-TYPE THERMO-PLASTIC COATED EXPANDED STEEL SEATS AND TOP**

DATE **3-03-10**

DWG. NO. **AI-1501**