



Model SQTK/G-4UP 5 plank, 48" square top,
Portable Square Table for kids with hot dip galvanized frame
and untreated Southern Yellow Pine planks

- **Scaled to fit children and their activities**
- **Square design optimizes table top usage and creates a more intimate setting**
- **Square table fits into more compact areas**
- **Nontip, nontrip, walk-through design**
- **All welded corner frames are fabricated from 1-1/2" diameter steel pipe**
- **Cross braces square up the corner frames and strengthen the table**
- **Frames are hot dip galvanized after fabrication for superior corrosion resistance**
- **Precision drilled, Untreated #1 Southern Yellow Pine Seat and Top Planks**
- **Quality construction throughout**

SPECIFICATIONS:

- **Model SQTK-4** has a nominal 48" square table top utilizing (5) top planks. The table is scaled to fit children.
- Table frame design incorporates nontip, nontrip, walk-through features. Bends are tightly formed to prevent tipping when weight is on one side.
- Four SQTK Series corner frames are each of one-piece welded construction made from 1-1/2" dia. x 1/8" wall structural steel tubing and seat supports of 1-3/4" x 1-3/4" x 1/8" die formed steel angle.
- Nominal table height is 22". Nominal seat height are 12".
- Top planks are supported and attached to corner frames by two 1-3/4" x 1-3/4" x 1/8" die formed steel angles.
- Corner frames are connected by two cross braces constructed of 1-5/16" O.D. steel pipe.
- All fasteners are provided for table assembly.
- **Standard:** All steel frame components are hot-dip galvanized after fabrication to ASTM-A123 to maintain an average zinc coating of 2.0 oz. per sq. ft. of surface area (indicated by "/G" following the SQTK in model no., e.g. SQTK/G-4UP).
- **Standard:** Lumber is Untreated #1 grade Southern Yellow Pine (indicated by "UP" in model no., e.g. SQTK/G-4UP) 2" x 10" nominal sized planks, kiln dried to reduce moisture content. All lumber is precision drilled to facilitate assembly and has all exposed edges removed to a 3/8" radius.
- **Optional:** Treated #1 Southern Yellow Pine is readily available and is pressure treated (KDAT) to preserve wood against decay. To specify, change "UP" in model no. to "TP", e.g. SQTK/G-4TP. (Cedar, Fir and Redwood are available when in stock -please inquire.)
- **Optional:** Color choices of powder coated steel frame components. For optional colors choices see Specification Bulletin #SPC-CO-001.
- **Optional:** Table is provided with umbrella holes in table tops and cup and collar sets for mounting umbrellas. To specify, add "/U" to the end of the model no., e.g. SQTK/G-4UP/U.

AVAILABLE OPTIONS

- Powder Coat Finish in choice of colors for steel frame components
- Pressure treated #1 Southern Yellow Pine lumber (Cedar, Fir, or Redwood lumber when in stock)
- Umbrella

RJThomas Mfg. Co., Inc.

PO Box 946 • Cherokee, IA 51012-0946 • PH: 712-225-5115 • 800-762-5002 • FAX: 712-225-5796

E-Mail: pilotrock@rjthomas.com • Web Site: <http://www.pilotrock.com>

© 2017 RJThomas Mfg. Co., Inc. PILOT ROCK® Park Products is a registered trademark of RJThomas Mfg. Co., Inc.

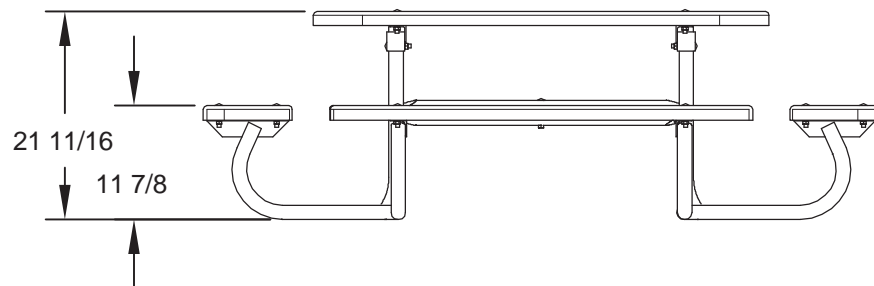
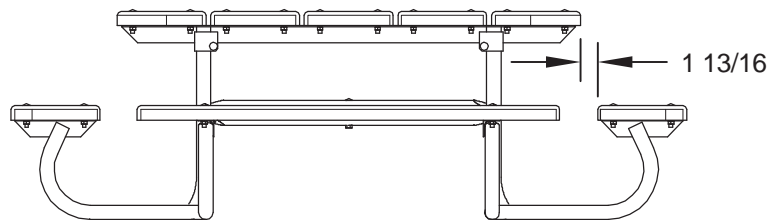
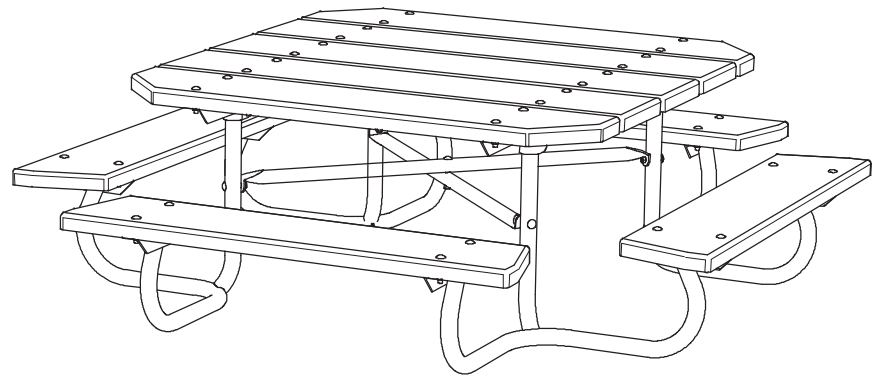
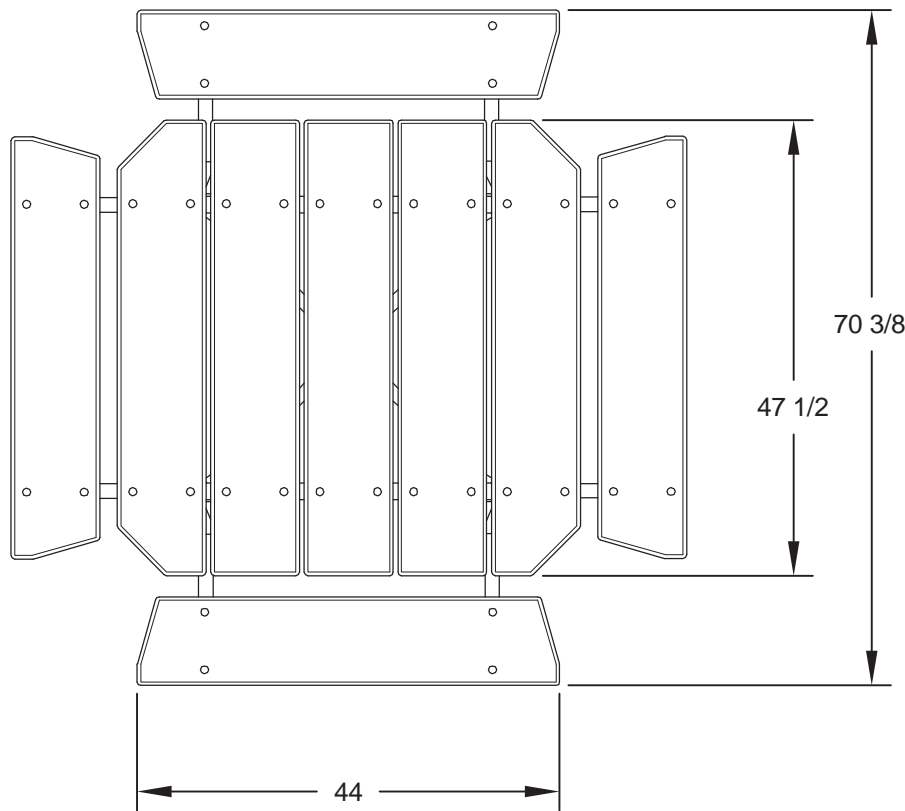

ALL DIMENSIONS IN INCHES

RJThomas Mfg. Co., Inc.
P.O. Box 946 • Cherokee, IA 51012-0946

DRAWN BY
WWM

TITLE **SQTK SERIES 4 FOOT PORTABLE SQUARE TABLE FOR KIDS WITH LUMBER TOP AND SEAT PLANKS**

DATE **02-21-11**

DWG. NO. **AI-1987**