

# T100 Series Portable Round Table with Thermo-plastic Coated Cut Steel Plate Top and Curved Seats



*Model T104/G-4SP/TA 4 Ft. Round Portable Table  
with hot dip galvanized frames and gray thermo-plastic coated  
cut steel plate top and curved seats*

- **Nontip, nontrip, walk-through design**
- **10 ga. cut steel plate top and seat surfaces**
- **All welded corner frames are fabricated from 1-1/2" diameter steel pipe**
- **1-5/16" OD Cross braces**
- **Thermo-plastic Coating heat fused to Cut Steel Plate Top and Seats for durability**
- **Thermo-plastic Coating formulated with U.V. stabilizers for ultraviolet protection**
- **Quality construction throughout**

## AVAILABLE OPTIONS

- **Powder Coat Finish in choice of colors for steel frame components**
- **Choice of colors of Thermo-plastic Coating**
- **Umbrella**

## SPECIFICATIONS:

- Four **T100 Series** corner frames are each a one-piece welded construction made from 1-1/2" dia. x 1/8" wall structural steel tubing and seat supports of 1-3/4" x 1-3/4" x 1/8" die formed steel angle.
- Table frame design incorporates nontip, nontrip, walk-through features. Bends are tightly formed to prevent tipping when weight is on one side.
- Nominal table height is 30-1/2". Nominal seat height is 18-1/2".
- Top is supported and attached to corner frames by two 1-3/4" x 1-3/4" x 1/8" die formed steel angles.
- Corner frames are connected by two cross braces constructed of 1-5/16" O.D. 14 ga. wall steel pipe.
- Table top and seats are each a one-piece welded construction, fabricated from 10 ga. cut steel plate welded to 10 ga. x 2" formed steel edge bands and reinforced by 1/8" steel bars and 1-1/4" x 1/8" angle.
- **Standard:** All steel frames components are hot-dip galvanized after fabrication to ASTM-A123 to maintain an average zinc coating of 2.0 oz. per sq. ft. of surface area (indicated by "/G" in model no., e.g. T104/G-4SP/TW).
- **Standard:** All steel surfaces of the top and seats are covered with a thermo-plastic coating in a brown color (indicated by "TW" in model no., e.g. T104/G-4SP/TW). The UV-stabilized thermo-plastic coating is applied in a multi step process of material preparation and finish application designed to permanently heat fuse and bond the finish to the steel. The thermo-plastic polyethylene finish is impact resistant, does not support mold or mildew, and the textured matte surface is less susceptible to marring and scuffing.
- **Standard:** Table is provided with umbrella cup and collar sets for mounting umbrellas.
- All fasteners are provided for assembly.
- **Optional:** Color choices of powder coated steel frame components. See Specification Bulletin #SPC-CO-001.
- **Optional:** Color choices of Thermo-plastic coated steel components. For optional colors choices see Specification Bulletin #SPC-CO-001.
- **Optional:** An umbrella is available. Please inquire for details.

**RJ Thomas Mfg. Co., Inc.**

PO Box 946 • Cherokee, IA 51012-0946 • PH: 712-225-5115 • 800-762-5002 • FAX: 712-225-5796  
E-mail: pilotrock@rjthomas.com • Web Site: <http://www.pilotrock.com>

© 2017 RJ Thomas Mfg. Co., Inc. PILOT ROCK® Park Products is a registered trademark of RJ Thomas Mfg. Co., Inc.

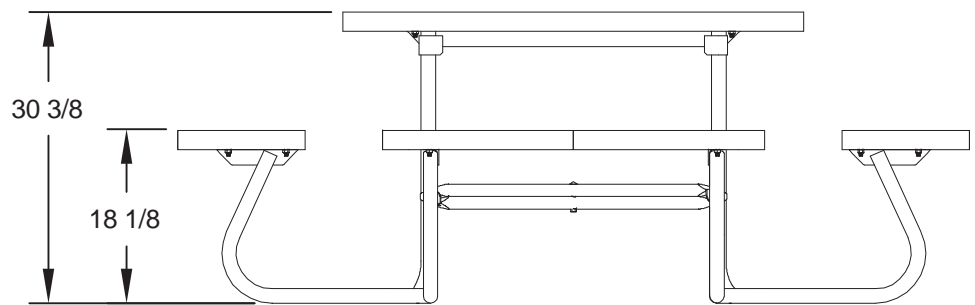
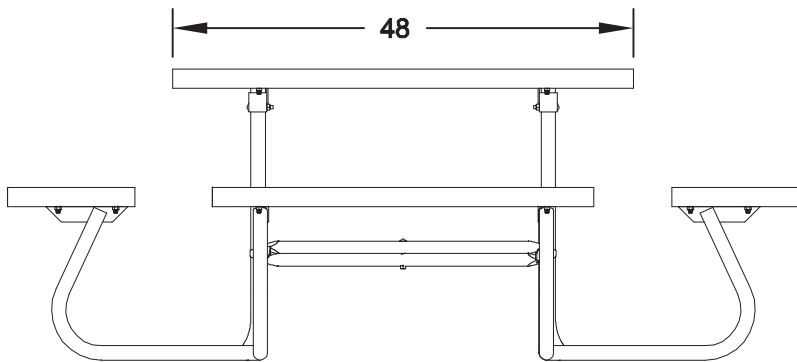
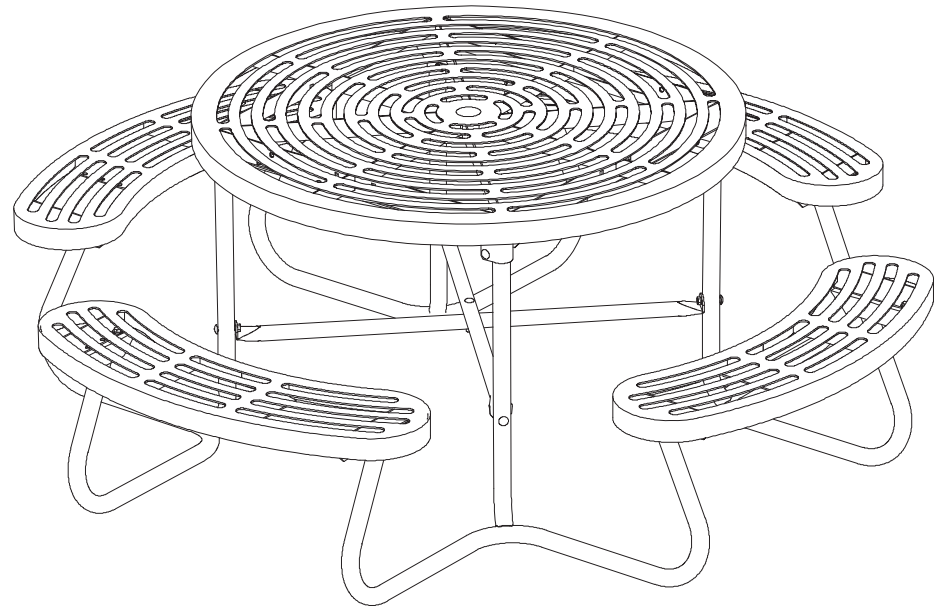
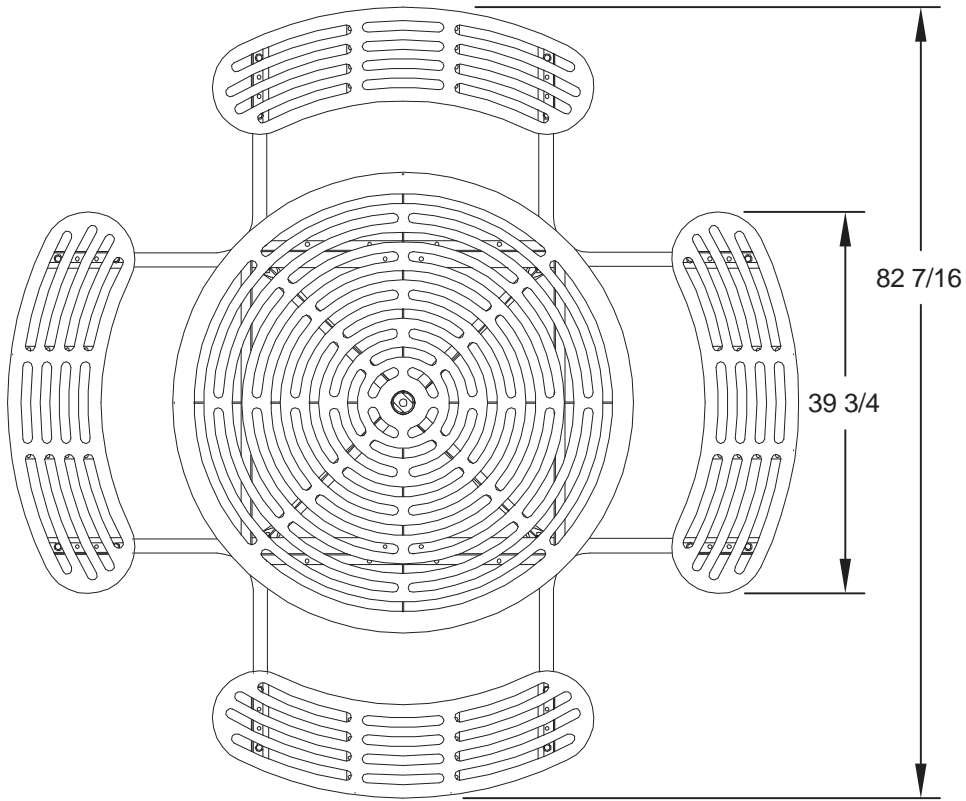

ALL DIMENSIONS IN INCHES

R. J. **THOMAS MFG. Co., INC.**  
 P.O. Box 946 • Cherokee, IA 51012

DRAWN BY  
**WWM**

TITLE **MODEL T104 PORTABLE ROUND TABLE**  
**WITH THERMO-PLASTIC COATED CUT STEEL PLATE TOP AND CURVED SEATS**

DATE 10-07-11

DWG. NO. **AI-2012**