



Model T134/G-4RN 4 Ft. Round Portable Table
with hot dip galvanized frames and green thermo-plastic coated
R-Type perforated steel top and contour seats

- **Nontip, nontrip, walk-through design**
- **Four contour seats hold up to eight people**
- **All welded corner frames are fabricated from 1-1/2" diameter steel pipe**
- **1-5/16" OD Cross braces**
- **Thermo-plastic Coating heat fused to Perforated Steel Top and Seats for durability**
- **Thermo-plastic Coating formulated with U.V. stabilizers for ultraviolet protection**
- **Quality construction throughout**

AVAILABLE OPTIONS

- **Powder Coat Finish in choice of colors for steel frame components**
- **Choice of colors of Thermo-plastic Coating**
- **Umbrella**

SPECIFICATIONS:

- Four **T100 Series** corner frames are each a one-piece welded construction made from 1-1/2" dia. x 1/8" wall structural steel tubing and seat supports of 1-3/4" x 1-3/4" x 1/8" die formed steel angle.
- Table frame design incorporates nontip, nontrip, walk-through features. Bends are tightly formed to prevent tipping when weight is on one side.
- Nominal table height is 30-1/2". Nominal seat height is 18-1/2".
- Top is supported and attached to corner frames by two 1-3/4" x 1-3/4" x 1/8" die formed steel angles.
- Corner frames are connected by two cross braces constructed of 1-5/16" O.D. 14 ga. wall steel pipe.
- Perforated steel is 14 ga. with 9/16" dia. holes in a 13/16" center to center in-line pattern. Table top is a one-piece welded construction, fabricated from perforated steel surface with 10 ga. x 2" formed vertical edges on all sides and reinforced by a 10 ga. die-formed angle substructure. Substructure includes all mounting holes for easy assembly.
- Table is provided with four 45" long contoured seats. Each seat is a one-piece welded construction, fabricated from a perforated steel surface welded to a 1/4" x 1-1/2" flat steel substructure. Exposed edges of seat have a rolled 1-1/2" radius. Substructure includes all mounting holes for assembly.
- **Standard:** All steel frames components are hot-dip galvanized after fabrication to ASTM-A123 to maintain an average zinc coating of 2.0 oz. per sq. ft. of surface area (indicated by "/G" in model no., e.g. T134/G-4RW).
- **Standard:** All steel surfaces of the top, center hub, and seats are covered with a thermo-plastic coating in a Brown color (indicated by "RW" in model no., e.g. T134/G-4RW). The UV-stabilized thermo-plastic coating is applied in a multi step process of material preparation and finish application designed to permanently heat fuse and bond the finish to the steel. The thermo-plastic polyethylene finish is impact resistant, does not support mold or mildew, and the textured matte surface is less susceptible to marring and scuffing.
- **Standard:** Table is provided with umbrella cup and collar sets for mounting umbrellas.
- All fasteners are provided for assembly.
- **Optional:** Color choices of powder coated steel frame components. See Specification Bulletin #SPC-CO-001.
- **Optional:** Color choices of Thermo-plastic coated steel components. For optional colors choices see Specification Bulletin #SPC-CO-001.
- **Optional:** An umbrella is available. Please inquire.

RJ Thomas Mfg. Co., Inc.

PO Box 946 • Cherokee, IA 51012-0946 • PH: 712-225-5115 • 800-762-5002 • FAX: 712-225-5796
E-mail: pilotrock@rjthomas.com • Web Site: <http://www.pilotrock.com>

© 2018 RJ Thomas Mfg. Co., Inc. PILOT ROCK® Park Products is a registered trademark of RJ Thomas Mfg. Co., Inc.

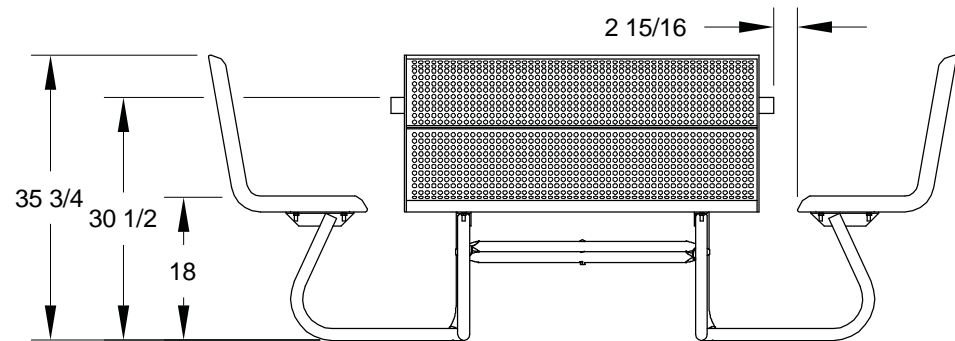
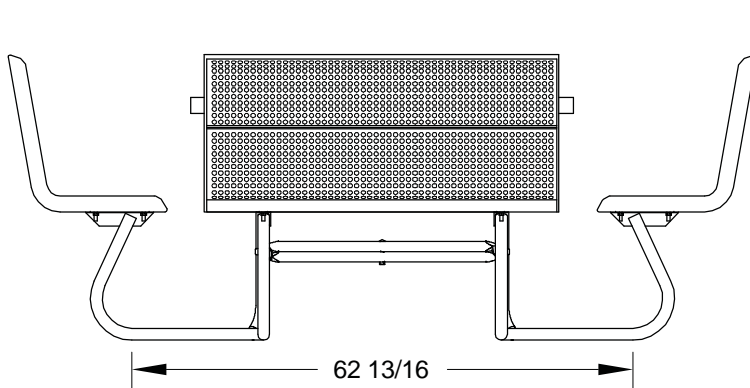
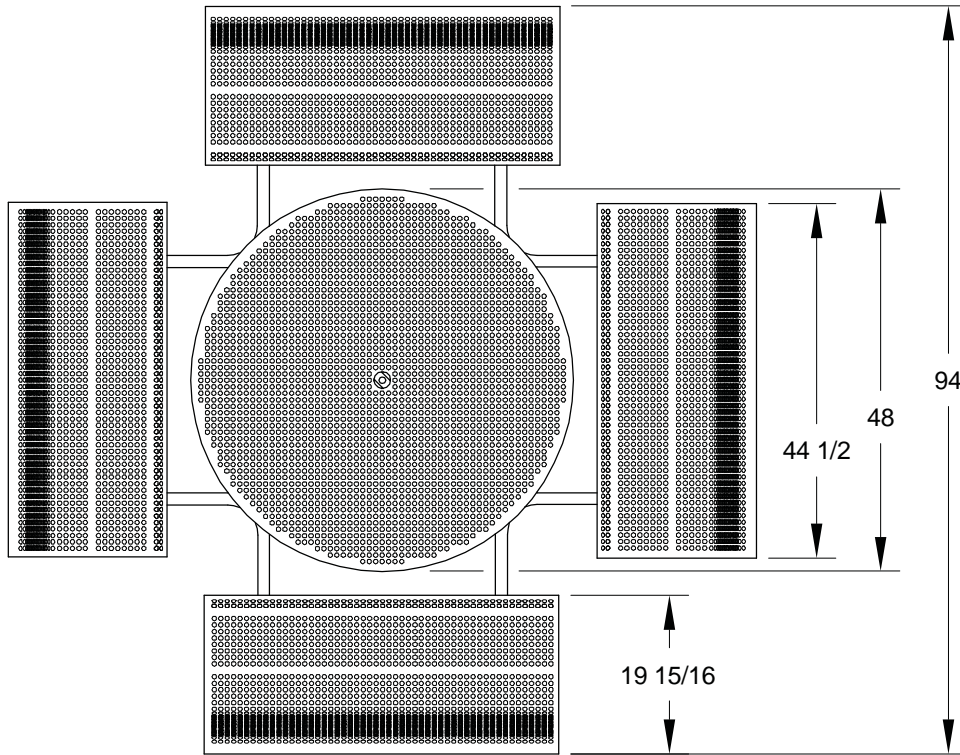

ALL DIMENSIONS IN INCHES

RJThomas Mfg. Co., Inc.
P.O. Box 946 • Cherokee, IA 51012-0946

DRAWN BY
WWM

TITLE **MODEL T134 PORTABLE BOLT TOGETHER ROUND TABLE
WITH THERMO-PLASTIC COATED R-TYPE
PERFORATED STEEL TOP AND CONTOUR SEATS**

DATE **1-13-11**

DWG. NO. **AI-1977**