

Model T303/CB-4RR Embedded Mount, Single Pedestal, Round Accessible Table with black powder coat frames, with red R-Type thermo-plastic coated 4 ft. dia. perforated steel top and curved seats.

- **Bolt together, embedded mount, single pedestal frame design**
- **(3) Curved seats accommodate up to six people**
- **One seat and support arm have been removed to provide wheelchair access**
- **Sturdy 6" square center pedestal, 3-1/2" diameter round radial seat supports**
- **Frames are hot dip galvanized after fabrication for superior corrosion resistance**
- **Thermo-plastic Coating heat fused to Perforated Steel Top and Seats for durability**
- **Thermo-plastic Coating formulated with U.V. stabilizers for ultraviolet protection**
- **Quality construction throughout**

AVAILABLE OPTIONS

Powder Coat Finish in choice of colors for steel frame components
Choice of colors of Thermo-plastic Coating
Umbrella

SPECIFICATIONS:

- **T300 Series** table frame incorporates a 6" square single center pedestal post designed to be embedded in a concrete footing.
- **Model T303/G-4** has a nom. 4 ft. diameter top. Curved seats are 40" in length. Wheelchair access on one side.
- Three seat support frames are each a one-piece welded construction of 3-1/2" dia. x 11 ga. wall structural steel tubing, a 2-3/8" dia. 10 ga. wall tube, and 2" x 2" x 1/8" die formed steel angles designed to resist lateral torsion and deflection when loaded.
- Frame is designed in a theft-proof manner with all fasteners extending into the central post to prevent removal once the table is assembled.
- **Model T303/G-4** has a nom. 4 ft. diameter top. Curved seats are 39-3/4" long.
- Nominal table height is 32". Nominal seat height is 20".
- All fasteners are provided for assembly.
- **Standard:** All steel frame components are hot-dip galvanized after fabrication to ASTM-A123 to maintain an average zinc coating of 2.0 oz. per sq. ft. of surface area (indicated by "/G" in model no., e.g. T303/G-4RW).
- Table top and seats are each a one-piece welded construction, fabricated from 14 ga. perforated steel surface with 10 ga. x 2" formed vertical edges on all sides and reinforced by a 10 ga. die-formed angle substructure. Substructure includes all mounting holes for easy assembly.
- Table top includes a reinforced center hole for installation of optional umbrella with 1-1/2" dia. pole.
- **Standard:** All steel surfaces of the top and seats are covered with a thermo-plastic coating in a Brown color (indicated by "RW" in model no., e.g. T303/G-4RW). The UV-stabilized thermo-plastic coating is applied in a multi step process of material preparation and finish application designed to permanently heat fuse and bond the finish to the steel. The thermo-plastic polyethylene finish is impact resistant, does not support mold or mildew, and the textured matte surface is less susceptible to marring and scuffing.
- **Optional:** Color choices of powder coated steel frame components. See Specification Bulletin #SPC-CO-001.
- **Optional:** Color choices of Thermo-plastic coated steel components. For optional colors choices see Specification Bulletin #SPC-CO-001.
- **Optional:** An umbrella is available. Please inquire for details.

RJ Thomas Mfg. Co., Inc.

PO Box 946 • Cherokee, IA 51012-0946 • PH: 712-225-5115 • 800-762-5002 • FAX: 712-225-5796
E-mail: pilotrock@rjthomas.com • Web Site: <https://www.pilotrock.com>

© 2023 RJ Thomas Mfg. Co., Inc. PILOT ROCK® Park Products is a registered trademark of RJ Thomas Mfg. Co., Inc.

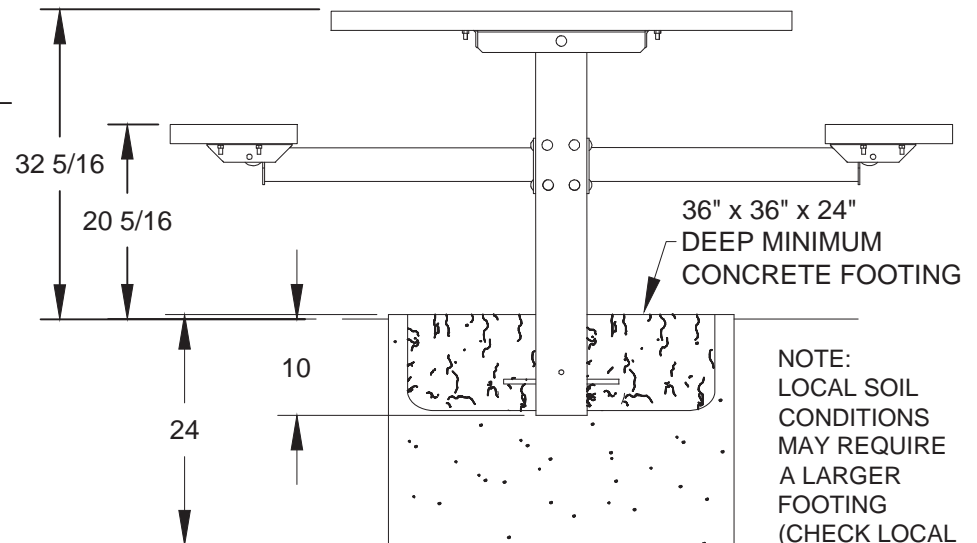
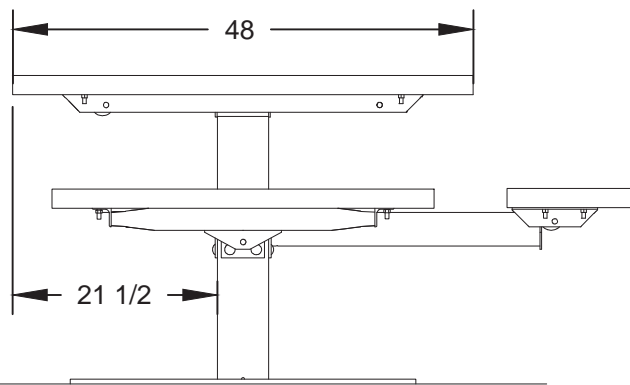
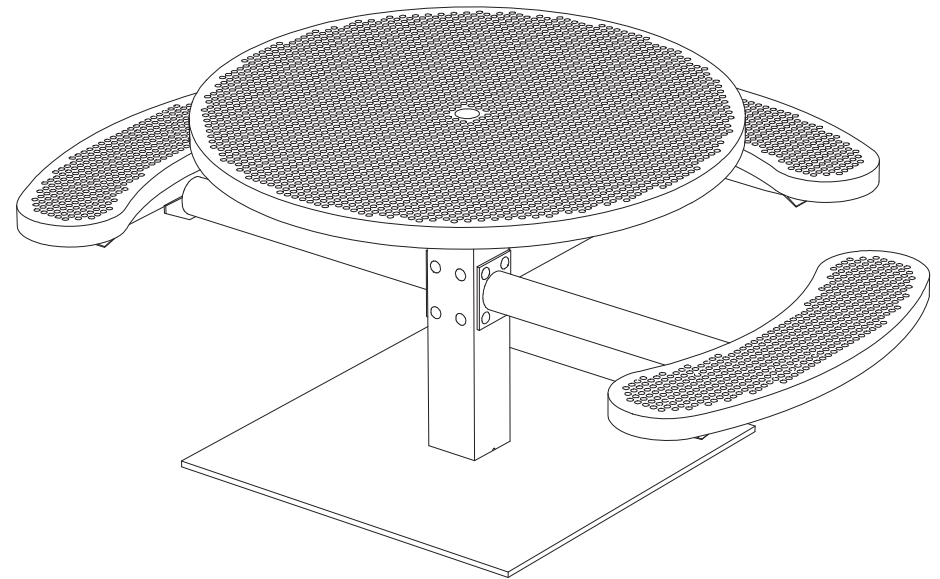
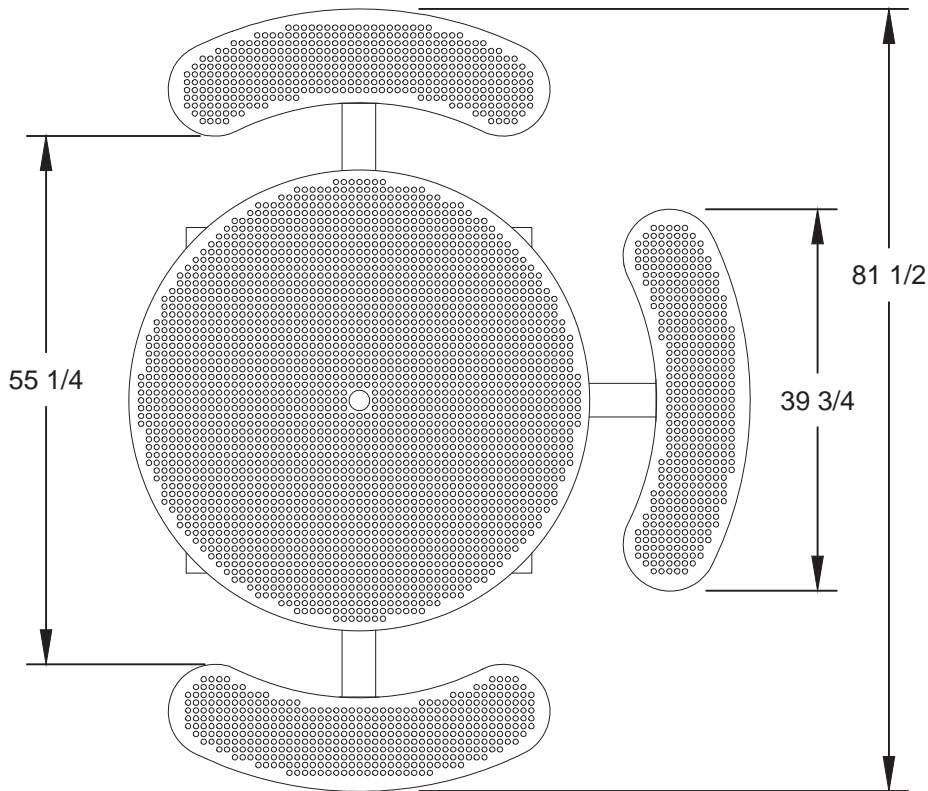

NOTE:
LOCAL SOIL
CONDITIONS
MAY REQUIRE
A LARGER
FOOTING
(CHECK LOCAL
CODES)

ALL DIMENSIONS IN INCHES

RJThomas Mfg. Co., Inc.
P.O. Box 946 • Cherokee, IA 51012-0946

DRAWN BY
JGJ

TITLE **MODEL T303 SINGLE PEDESTAL EMBEDDED MOUNT ROUND ACCESSIBLE TABLE
WITH R-TYPE THERMO-PLASTIC COATED PERFORATED STEEL
TOP AND CURVED SEATS**

DATE **02-01-23**

DWG. NO. **AI-3042**