



Model T334/CR-4RW Embedded Mount, Single Pedestal, 4 ft. dia. Round Table with red powder coat frames, with brown thermo-plastic coated R-Type perforated steel top and contour seats.

- **Embedded mount, single pedestal frame design**
- **Four contour seats accommodate eight adults**
- **Frames are hot dip galvanized after fabrication for superior corrosion resistance**
- **Thermo-plastic Coating heat fused to Perforated Steel Top and Seats for durability**
- **Thermo-plastic Coating formulated with U.V. stabilizers for ultraviolet protection**
- **Quality construction throughout**

AVAILABLE OPTIONS

- **Powder Coat Finish in choice of colors for steel frame components**
- **Choice of colors of Thermo-plastic Coating**
- **Umbrella**

SPECIFICATIONS:

- **T300 Series** table top and seats are suspended from one centrally located 6" sq. x 7 ga. (3/16") wall steel post embedded in a concrete footing. Each seat is supported by a 3-1/2" dia. steel tube designed to resist lateral torsion and deflection when fully loaded, a 2-3/8" dia. crossmember, and two 2" x 2" x 1/8" die formed steel angle mounts. The top is supported by a subframe of 7 ga. channel, two 2" x 2" x 1/8" die formed steel angle mounts, and 2-3/8" dia. reinforcing tube.
- Frame is designed in a theft-proof manner with all fasteners connected to the central post so that the carriage bolts extend into the central post and are nonremovable once the table is assembled.
- **Model T334/G-4** has a nom. 4 ft. diameter top.
- Nominal table height is 32". Nominal seat height is 20".
- All fasteners are provided for assembly.
- **Standard:** All steel frame components are hot-dip galvanized after fabrication to ASTM-A123 to maintain an average zinc coating of 2.0 oz. per sq. ft. of surface area (indicated by "/G" in model no., e.g. T334/G-4RW).
- Perforated steel top and seats are 14 ga. with 9/16" dia. holes in a 13/16" center to center in-line pattern. Table top is a one-piece welded construction, fabricated from perforated steel surface with 10 ga. x 2" formed vertical edges on all sides and reinforced by a 10 ga. die-formed angle substructure. Substructure includes all mounting holes for easy assembly.
- Table is provided with four 45" wide chair seats. Each seat is a one-piece welded construction, fabricated from a perforated steel surface welded to a 1/4" x 1-1/2" flat steel substructure. Exposed edges of seat have a rolled 1-1/2" radius. Substructure includes all mounting holes for assembly.
- Table top includes a reinforced center hole for installation of optional umbrella with 1-1/2" dia. pole.
- **Standard:** All steel surfaces of the top and seats are covered with a thermo-plastic coating in a Brown color (indicated by "RW" in model no., e.g. T334/G-4RW). The UV-stabilized thermo-plastic coating is applied in a multi step process of material preparation and finish application designed to permanently heat fuse and bond the finish to the steel. The thermo-plastic polyethylene finish is impact resistant, does not support mold or mildew, and the textured matte surface is less susceptible to marring and scuffing.
- **Optional:** Color choices of powder coated steel frame components. See Specification Bulletin #SPC-CO-001.
- **Optional:** Color choices of Thermo-plastic coated steel components. For optional colors choices see Specification Bulletin #SPC-CO-001.
- Wheelchair accessible models may be created by excluding one seat (Model T333) or two seats (Model T332).
- **Optional:** An umbrella is available. Please inquire.

RJ Thomas Mfg. Co., Inc.

PO Box 946 • Cherokee, IA 51012-0946 • PH: 712-225-5115 • 800-762-5002 • FAX: 712-225-5796
E-mail: pilotrock@rjthomas.com • Web Site: <https://www.pilotrock.com>

© 2023 RJ Thomas Mfg. Co., Inc. PILOT ROCK® Park Products is a registered trademark of RJ Thomas Mfg. Co., Inc.

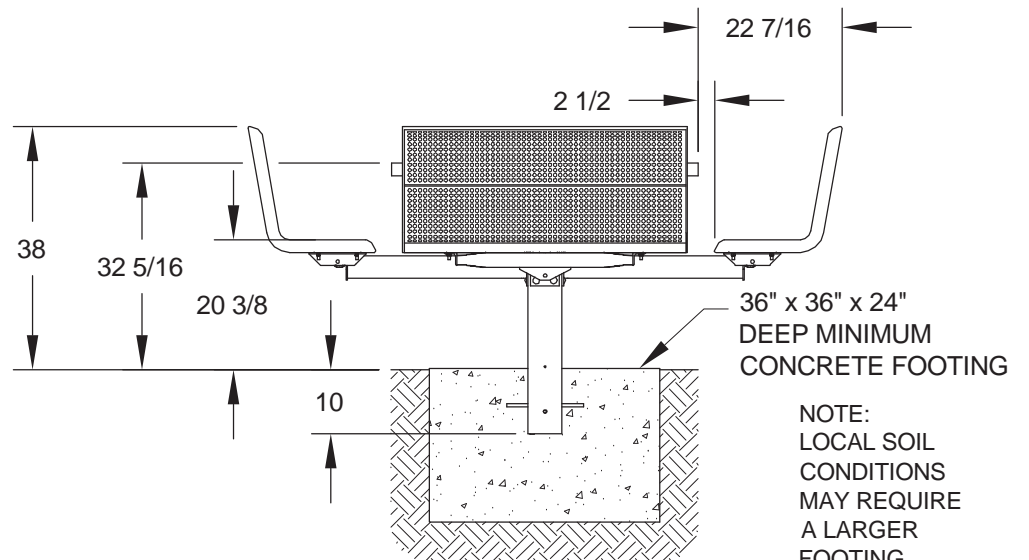
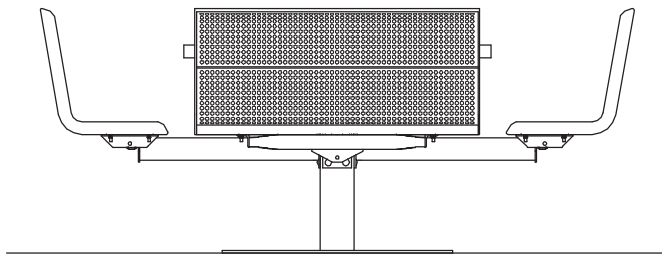
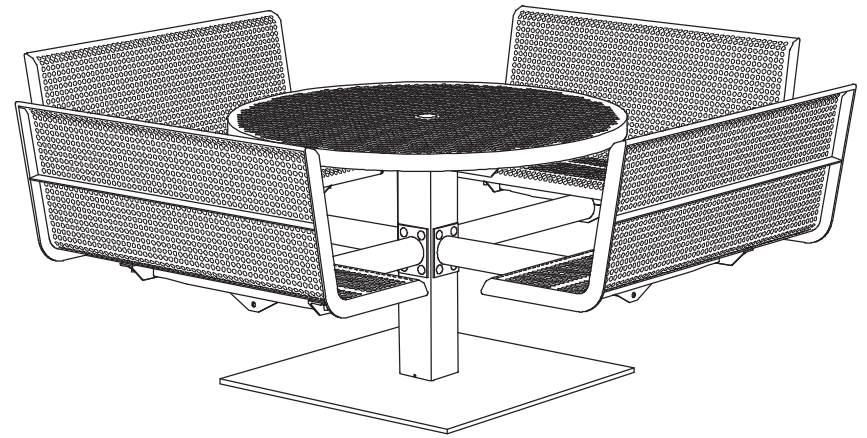
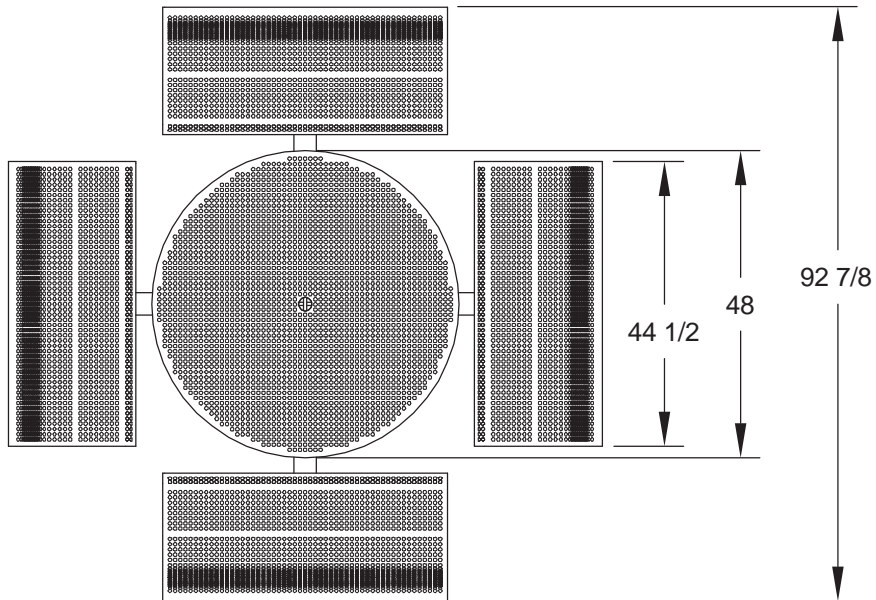

NOTE:
LOCAL SOIL
CONDITIONS
MAY REQUIRE
A LARGER
FOOTING
(CHECK LOCAL
CODES)

ALL DIMENSIONS IN INCHES

RJThomas Mfg. Co., Inc.
P.O. Box 946 • Cherokee, IA 51012-0946

DRAWN BY
WWM

TITLE **MODEL T334 EMBEDDED MOUNT SINGLE PEDESTAL ROUND TABLE WITH
THERMO-PLASTIC COATED R-TYPE PERFORATED STEEL TOP AND CONTOUR SEATS**

DATE 12-27-10

DWG. NO. **AI-1974**