



Model TPT/CE-6DA embedded mount twin pedestal table with burgundy powder coated frames, 6 ft. long with gray thermo-plastic coated expanded steel top and seats.

- **Permanent installation prevents theft**
- **Twin pedestal design allows easier cleaning under table**
- **Frames are hot-dip galvanized after fabrication for superior corrosion resistance**
- **Thermo-plastic coating heat fused to expanded steel top and seats for durability**
- **Thermo-plastic coating formulated with U.V. stabilizers for ultraviolet protection**

SPECIFICATIONS:

- **TPT Series** table frames are a one piece welded construction fabricated from a 1/8" wall x 4" x 4" square tube vertical post with two 3/16" wall x 2-1/2" x 2-1/2" horizontal seat support arms with 2" x 3" x 3/16" A-36 structural grade steel angles for attaching the seats and top. Exposed ends of square tubing are permanently sealed with welded-on steel end caps. Frames are designed to be embedded in a concrete footing.
- **Model TPT/G-6** is a nominal 6 ft. long.
- **Model TPT/G-8** is a nominal 8 ft. long.
- Nominal table height is 31-1/2". Nominal seat height is 18".
- **Standard:** All steel frame components are hot-dip galvanized after fabrication to ASTM-A123 to maintain an average zinc coating of 2.0 oz. per sq. ft. of surface area (indicated by "/G" in model no., e.g. TPT/G-6DW).
- **D-Type** top and seats are each a one-piece welded construction, fabricated from a 3/4-#9 expanded steel surface with 2" roll-formed 14 ga. steel vertical edges on all sides and reinforced by a strap and die-formed angle substructure.
- **Standard:** All steel surfaces of the top and seats are covered with a thermo-plastic coating in a Brown color (indicated by "DW" in model no., e.g. TPT/G-6DW). The UV-stabilized thermo-plastic coating is applied in a multi step process of material preparation and finish application designed to permanently heat fuse and bond the finish to the steel. The thermo-plastic polyethylene finish is impact resistant, does not support mold or mildew, and the textured matte surface is less susceptible to marring and scuffing.
- All galvanized fasteners are provided for assembly.
- **Optional:** All steel frame components have powder coat finish. See Specification Bulletin #SPC-CO-001.
- **Optional:** Color choices of thermo-plastic coated steel components. For optional colors choices see Specification Bulletin #SPC-CO-001.
- **Optional:** Frames shall be provided with a 3/8" x 10" x 10" steel base plate to bolt table to existing concrete pad. To specify add /P after the TPT in the model no., e.g. TPT/P/G-6DW. (Anchor bolts not included.)

AVAILABLE OPTIONS

- 6' or 8' lengths
- Choice of colors of powder coat finish on steel frame components
- Choice of colors of thermo-plastic coating
- Surface mount base plate

RJ Thomas Mfg. Co., Inc.

PO Box 946 • Cherokee, IA 51012-0946 • PH: 712-225-5115 • 800-762-5002 • FAX: 712-225-5796
E-mail: pilotrock@rjthomas.com • Web Site: <http://www.pilotrock.com>

© 2008 RJ Thomas Mfg. Co., Inc. PILOT ROCK® Park Products is a registered trademark of RJ Thomas Mfg. Co., Inc.

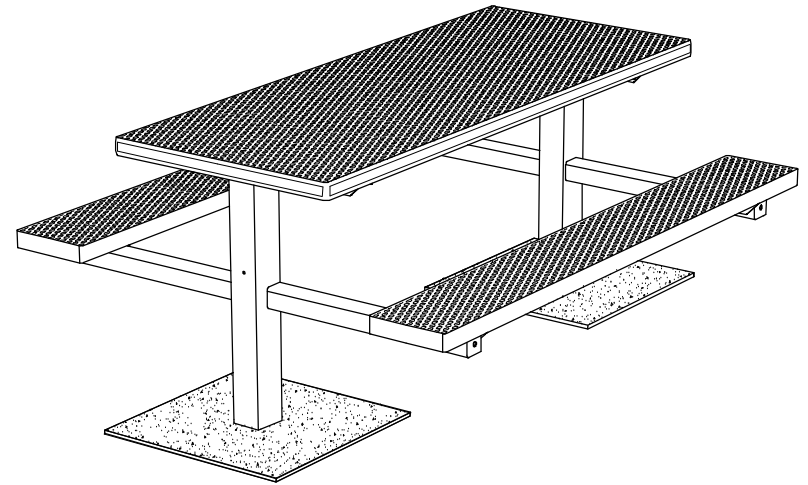
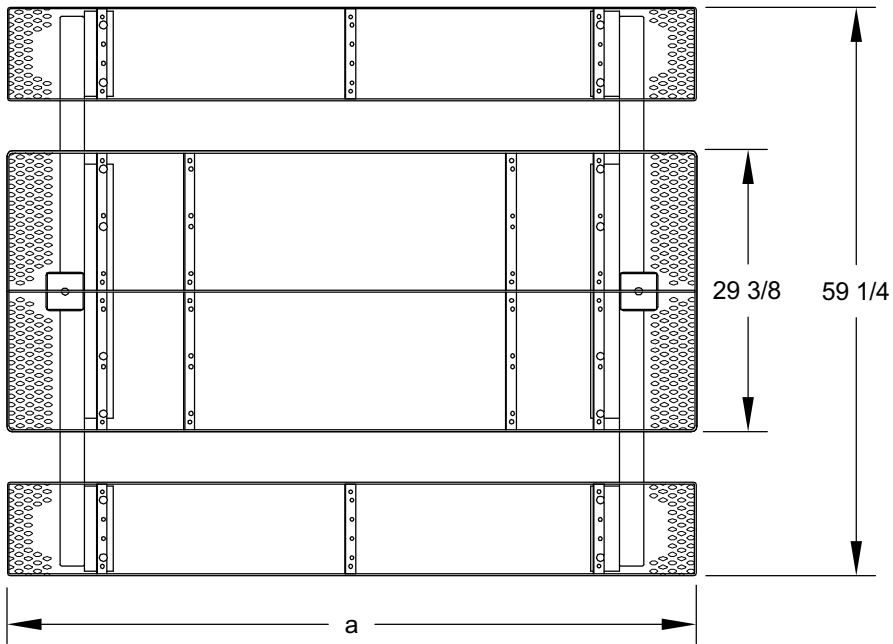

MODEL	DIMENSION	
	a	b
TPT-6	71 3/4	59 3/4
TPT-8	95 7/8	78

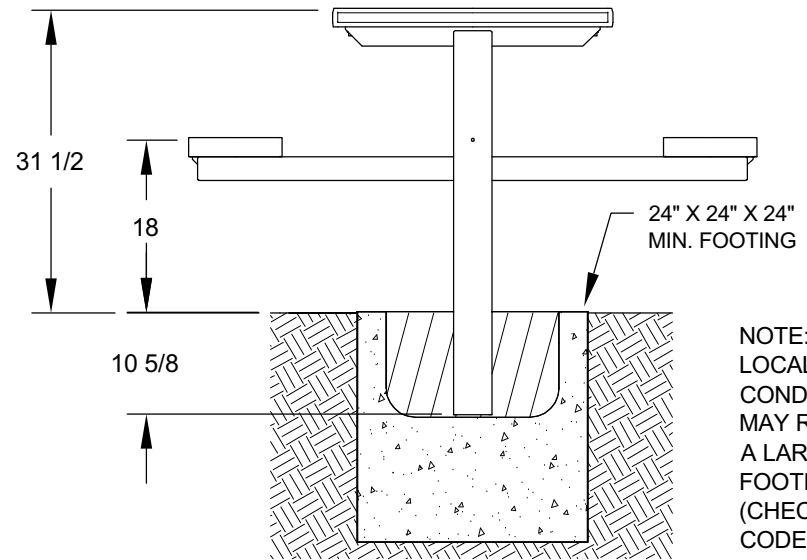
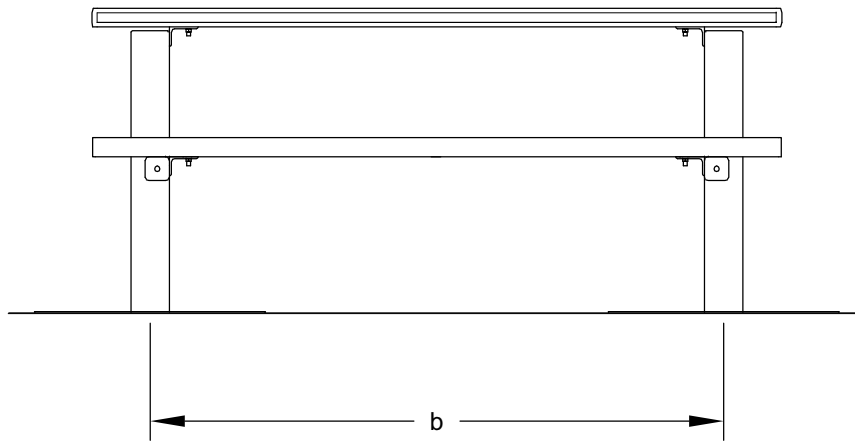

NOTE:
LOCAL SOIL
CONDITIONS
MAY REQUIRE
A LARGER
FOOTING
(CHECK LOCAL
CODES)

ALL DIMENSIONS IN INCHES

RJThomas Mfg. Co., Inc.
P.O. Box 946 • Cherokee, IA 51012-0946

DRAWN BY
WWM

TITLE TPT SERIES TWIN PEDESTAL 6 AND 8 FOOT EMBEDDED MOUNT TABLE
WITH D-TYPE THERMO-PLASTIC COATED EXPANDED STEEL TOP AND SEATS

DATE 2-12-10

DWG. NO. **AI-1918**