

**Model TQ703 4 Foot Surface Mount  
Square Frame Accessible Table  
with Recycled Plastic Top and Seats**



*Model TQ703/CB-4PR surface mount wheelchair accessible square frame table with black powder coated frames, 4 ft. square with red recycled plastic top and seats.*

- **Permanent surface mount installation**
- **ADA compliant wheelchair access at one end**
- **11 and 14 ga. square and rectangular steel tube frame construction**
- **2" x 4" 100% Recycled Plastic Seat and Top Planks with solid color and U.V. stabilizer for ultraviolet protection**
- **Simple bolt together assembly of nine pieces**
- **Powder coat finish on frames**

**SPECIFICATIONS:**

- **TQ700 Series** table frames are a bolt together assembly of welded components. Seat and top frames are 14 ga. wall x 1" x 2" rectangular steel tube. Leg frames are fabricated from 11 ga. wall x 2" x 2" square tube. A welded steel foot on each leg provides a 9/16" diameter hole for permanently anchoring table and seats to hard surfaces (anchors not included). Exposed ends of tubing are permanently sealed with welded-on steel end caps.
- **Model TQ703-4** is a nominal 4 ft. square.
- Nominal table height is 30". Nominal seat height is 17".
- Model TQ703 Series rectangular tables provide one wheelchair space at each end of table creating an ADA compliant space of 30" wide, 19" deep, and 27" from ground to bottom of table top for knee space, and minimum 9" above ground extending a total of 24" deep for toe space.
- **Standard:** All steel frame components have a black powder coat finish (indicated by "/CB" in model no., e.g. TQ703/CB-4PC).
- **Standard:** Top and seat frames have cedar colored 100% Recycled Plastic molded into 2" x 4" (nom.) planks (indicated by "PC" in model no., e.g. TQ703/CB-4PC) set flush with the top of the frame to provide an even surface. Planks run length-wise in the frames with a slight gap between them. Top and seat frames ship with planks factory installed, using galvanized fasteners.
- All stainless steel fasteners are provided for steel component assembly.
- **Optional:** Color choices of powder coat finish on steel frame components. See Specification Bulletin #SPC-CO-001.
- **Optional:** Color choices of Recycled Plastic components. See Specification Bulletin #SPC-CO-001.
- **Optional:** Four Model ANC3-4 Anchor Kits for permanent hard surface installation.

**AVAILABLE OPTIONS**

- **Choice of colors of powder coat finish on steel frame components**
- **Choice of colors of Recycled Plastic**

**RJ Thomas Mfg. Co., Inc.**

PO Box 946 • Cherokee, IA 51012-0946 • PH: 712-225-5115 • 800-762-5002 • FAX: 712-225-5796

E-mail: [pilotrock@rjthomas.com](mailto:pilotrock@rjthomas.com) • Web Site: <https://www.pilotrock.com>

© 2023 RJ Thomas Mfg. Co., Inc. PILOT ROCK® Park Products is a registered trademark of RJ Thomas Mfg. Co., Inc.

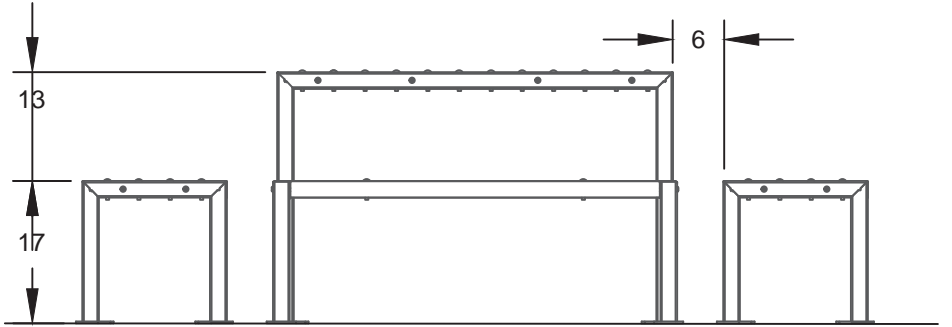
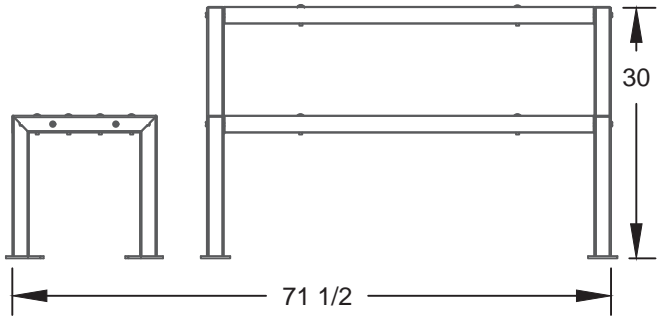
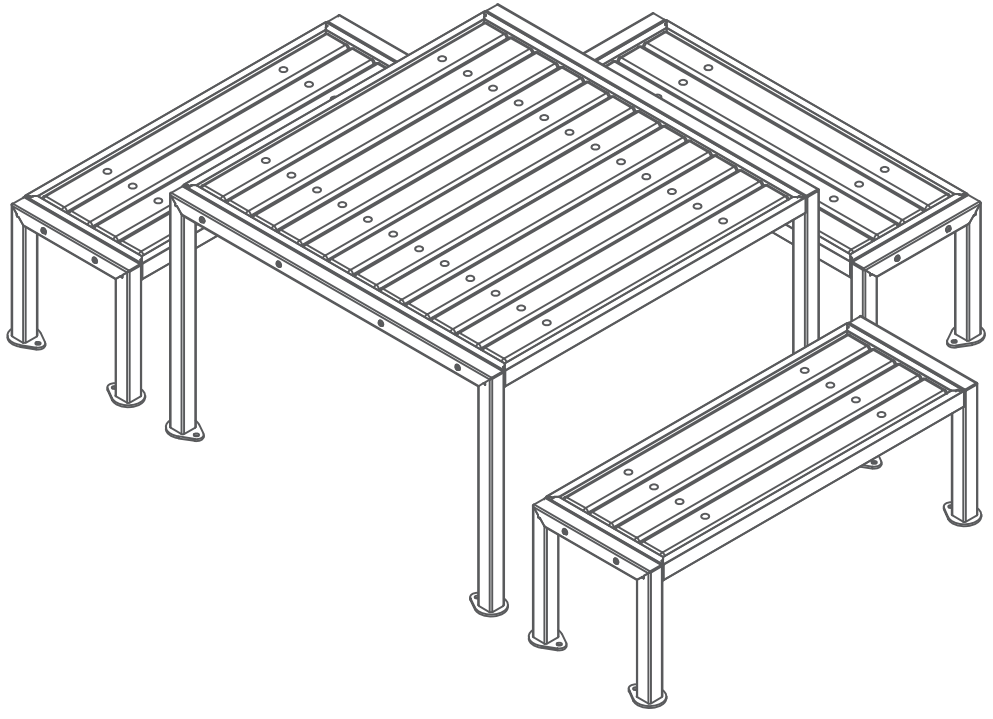
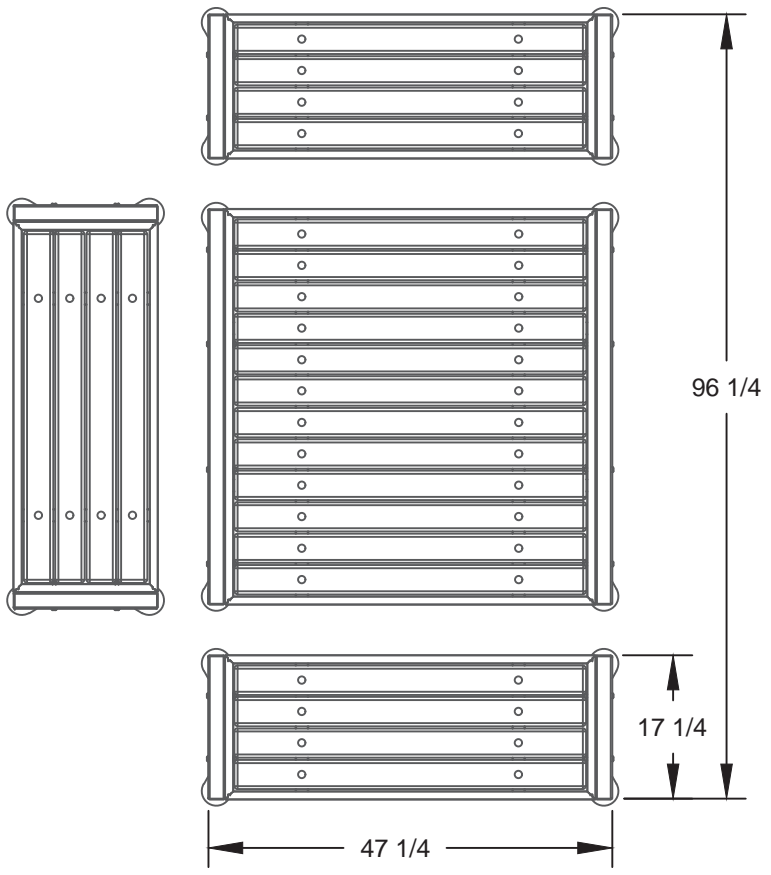

ALL DIMENSIONS IN INCHES

**RJThomas Mfg. Co., Inc.**  
 P.O. Box 946 • Cherokee, IA 51012-0946

DRAWN BY  
**JGJ**

TITLE TQ703-4 4 FOOT SQUARE FRAME ACCESSIBLE PICNIC TABLE WITH RECYCLED  
 PLASTIC TOP PLANKS AND 3 SEATS

DATE 04-28-23

DWG. NO. AI-3047