

**Model TQ704 4 Foot Surface Mount
Square Frame Picnic Table
with Recycled Plastic Top and Seats**



Model TQ704/CE-4PY surface mount 4 ft. square frame picnic table with burgundy powder coated frames and yellow recycled plastic top and seats.

- **Permanent surface mount installation**
- **11 and 14 ga. square and rectangular steel tube frame construction**
- **2" x 4" 100% Recycled Plastic Seat and Top Planks with solid color and U.V. stabilizer for ultraviolet protection**
- **Simple bolt together assembly**
- **Powder coat finish on frames**

SPECIFICATIONS:

- **TQ700 Series** table frames are a bolt together assembly of welded components. Seat and top frames are 14 ga. wall x 1" x 2" rectangular steel tube. Leg frames are fabricated from 11 ga. wall x 2" x 2" square tube. A welded steel foot on each leg provides a 9/16" diameter hole for permanently anchoring table and seats to hard surfaces (anchors not included). Exposed ends of tubing are permanently sealed with welded-on steel end caps.
- **Model TQ704-4** is a nominal 4 ft. square.
- Nominal table height is 30". Nominal seat height is 17".
- **Standard:** All steel frame components have a black powder coat finish (indicated by "/CB" in model no., e.g. TQ704/CB-4PC).
- **Standard:** Top and seat frames have cedar colored 100% Recycled Plastic molded into 2" x 4" (nom.) planks (indicated by "PC" in model no., e.g. TQ704/CB-4PC) set flush with the top of the frame to provide an even surface. Planks run length-wise in the frames with a slight gap between them. Top and seat frames ship with planks factory installed, using galvanized fasteners.
- All stainless steel fasteners are provided for steel component assembly.
- **Optional:** Color choices of powder coat finish on steel frame components. See Specification Bulletin #SPC-CO-001.
- **Optional:** Color choices of Recycled Plastic components. See Specification Bulletin #SPC-CO-001.
- **Optional:** Five Model ANC3-4 Anchor Kits for permanent hard surface installation.

AVAILABLE OPTIONS

- **Choice of colors of powder coat finish on steel frame components**
- **Choice of colors of Recycled Plastic**

RJ Thomas Mfg. Co., Inc.

PO Box 946 • Cherokee, IA 51012-0946 • PH: 712-225-5115 • 800-762-5002 • FAX: 712-225-5796

E-mail: pilotrock@rjthomas.com • Web Site: <https://www.pilotrock.com>

© 2023 RJ Thomas Mfg. Co., Inc. PILOT ROCK® Park Products is a registered trademark of RJ Thomas Mfg. Co., Inc.

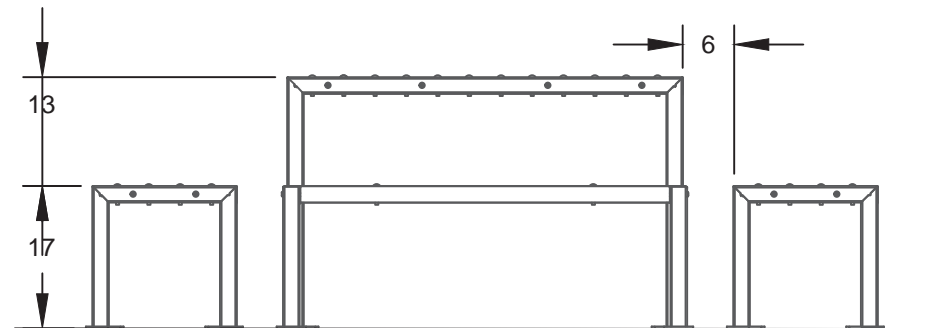
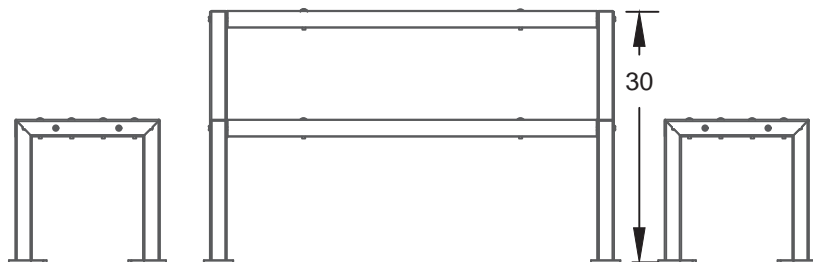
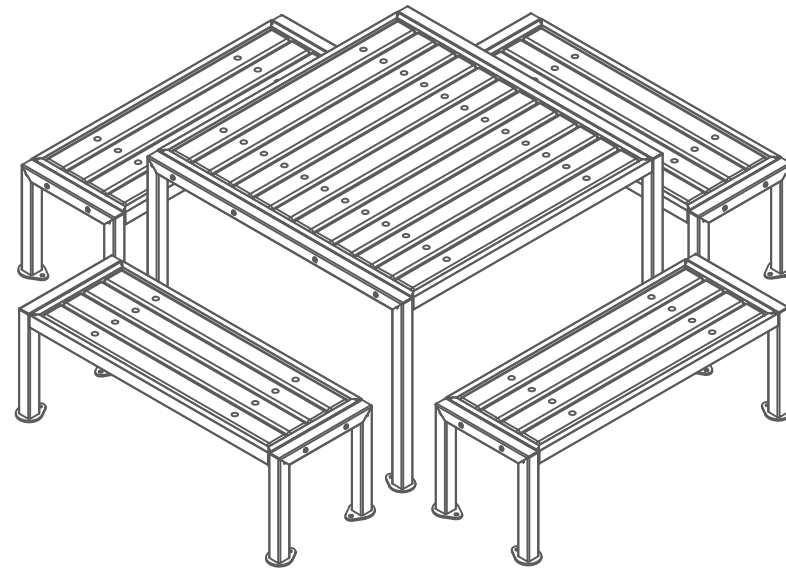
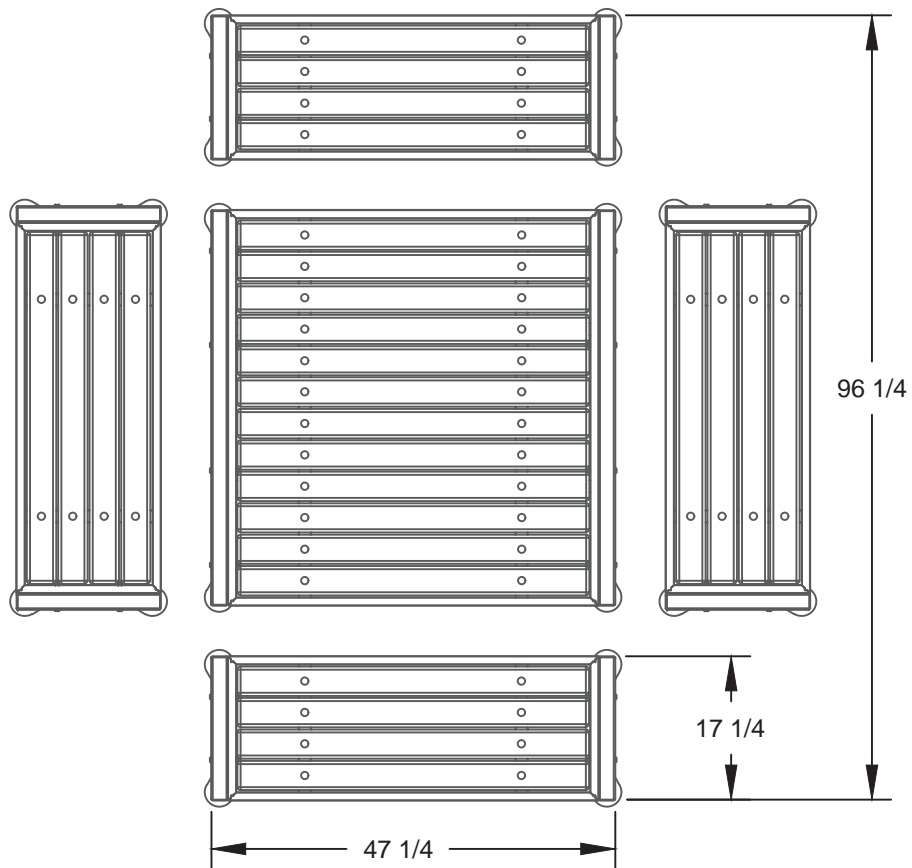

ALL DIMENSIONS IN INCHES

RJThomas Mfg. Co., Inc.
P.O. Box 946 • Cherokee, IA 51012-0946

DRAWN BY
JGJ

TITLE **TQ704-4 4 FOOT SQUARE FRAME PICNIC TABLE WITH RECYCLED PLASTIC TOP
PLANKS AND 4 SEATS**

DATE **04-28-23**

DWG. NO. **AI-3046**