



Model B412/CB-8HU Sign Bench, bolt-down surface mount, black powder coated frame, 8 ft. long, blue thermo-plastic coated perforated steel, seat and sign frame.

- **Bolt-down surface mount installation**
- **Sturdy, formed and welded steel frame construction**
- **Top cap opens for total access to the sign frame. Cap can be padlocked closed.**
- **The sign board slides in front of the back support. Your sign can be replaced as often as you want.**
- **Hot dip galvanized frame finish is standard**
- **Thermo-plastic Coating heat fused to steel seat and sign frame**
- **Thermo-plastic Coating formulated with U.V. stabilizers for ultraviolet protection**
- **Quality construction throughout**

AVAILABLE OPTIONS

4', 6', or 8' models

Powder Coat Finish in choice of colors for frame components

Thermo-plastic seat coating in your choice of colors

Order/reorder signage from Pilot Rock Signs

SPECIFICATIONS:

- **Model B412** end frames are one-piece, welded construction with a back and seat bracket of 2-3/8" x 1-1/2" x 1/8" nominal sized, die-formed channel, and a 2.375" (2-3/8") O.D. post to meet 2" nominal steel pipe size specifications. Frame foot is a flat base plate. A 17/32" square hole is provided in each end of foot for bolt-down surface mounting with concrete anchors (anchors not included)
- **Standard:** All steel frame components are hot-dip galvanized after fabrication to ASTM-A123 to maintain an average zinc coating of 2.0 oz. per sq. ft. of surface area (indicated by "/G" in model no., e.g. B412/G-8HU).
- Seat is a one-piece welded construction, fabricated from a 14 ga. perforated steel surface with 10 ga. x 2-1/2" roll-formed vertical edges on all sides and reinforced by a 10 ga. die-formed angle substructure. Substructure includes all mounting holes for easy assembly of bench.
- Sign frame is 10 ga. formed steel channel with 10 ga. angle reinforcements
- **Standard:** All steel surfaces of the seat and sign frame are covered with a thermo-plastic coating in a black color (indicated by "/HB" in model no., e.g. B412/CB-8HB). Other colors available.) The UV-stabilized thermo-plastic coating is applied in a multi step process of material preparation and finish application designed to permanently heat fuse and bond the finish to the steel. The thermo-plastic polyethylene finish is impact resistant, does not support mold or mildew, and the textured matte surface is less susceptible to marring and scuffing.
- All fasteners are provided for assembly.
- Black painted 3/4 in. MDO Sign Board back support for sign.
- Hinged top cap closes the sign frame and can be padlocked to secure the sign (padlocks not included- order (2) #PL-1). The sign cannot be removed when cap is closed.
- **Optional:** Custom made Pilot Rock Sign features: Sign is 16 in. tall by 4ft., 6ft., or 8ft long, .40 ga Alumilite aluminum laminate, 1/4 in. thick, polycarbonate core, a 3M vinyl digitally printed graphic material, a 3M protective lamination over the graphic.
- **Optional:** Color choices of powder coated steel frame components. For optional colors choices see Specification Bulletin #SPC-CO-001.
- **Optional:** Color choices of thermo-plastic coated components. For optional color choices, see Specification Bulletin #SPC-CO-001.

RJ Thomas Mfg. Co., Inc.

PO Box 946 • Cherokee, IA 51012-0946 • PH: 712-225-5115 • 800-762-5002 • FAX: 712-225-5796
E-mail: pilotrock@rjthomas.com • Web Site: <http://www.pilotrock.com>

© 2019 RJ Thomas Mfg. Co., Inc. PILOT ROCK® Park Products is a registered trademark of RJ Thomas Mfg. Co., Inc.

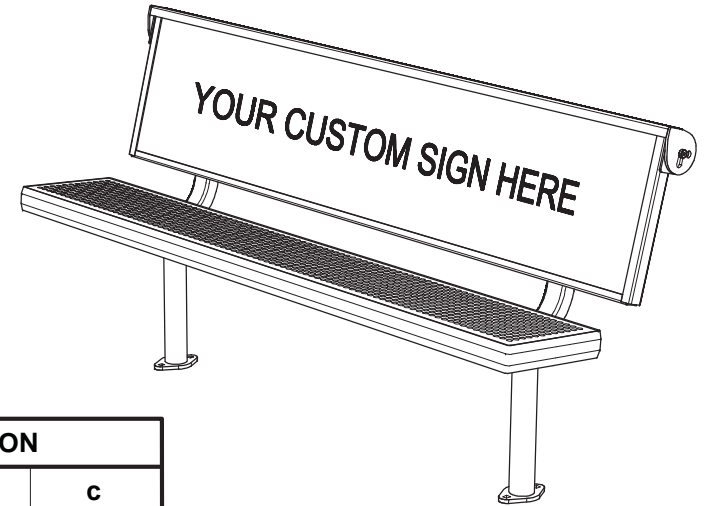
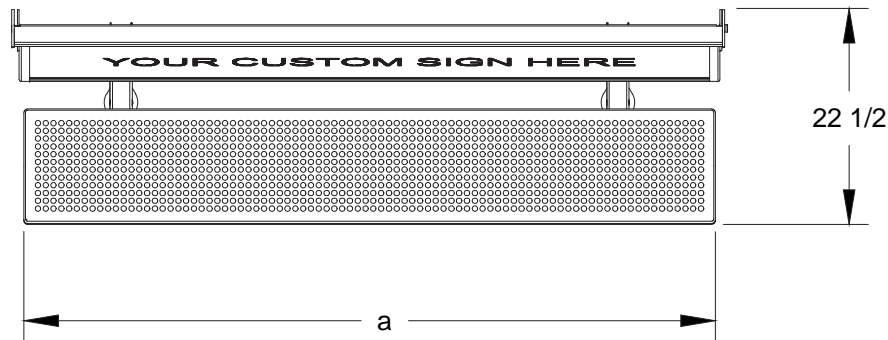

MODEL NUMBER	DIMENSION		
	a	b	c
B412-4	48	36	50
B412-6	72	51 3/4	74
B412-8	96	70	98

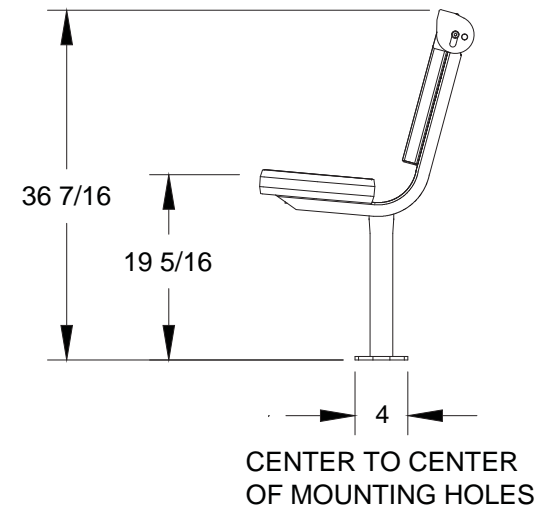
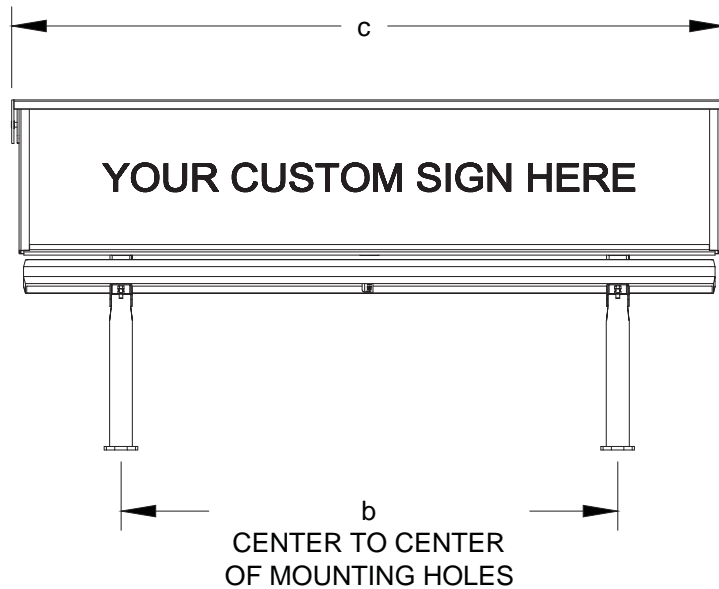

ALL DIMENSIONS IN INCHES

RJThomas Mfg. Co., Inc.
P.O. Box 946 • Cherokee, IA 51012-0946

DRAWN BY
MFI

TITLE SIGN BENCH SERIES MODEL B412 4, 6 AND 8 FOOT BOLT-DOWN MOUNT
PERFORATED STEEL SEAT

DATE 9-23-15

DWG. NO. **AI-2071**