

FCT Food Court Table with Fiberglass Top and Seats



Model FCT/G-4FG/YELLOW Food Court Table, galvanized frames, 4 ft. long, surface mount, with yellow fiberglass top and seats.

- **Seats four with small surface footprint**
- **Wheelchair or stroller access at both ends.**
- **All welded frames are fabricated from 2-3/8" diameter steel pipe.**
- **Frames are hot dip galvanized after fabrication for superior corrosion resistance.**
- **Umbrella Hole Centered on Table Top**

SPECIFICATIONS:

- **Model FCT** frames are one-piece welded construction, fabricated from 2.375" O.D. (2-3/8" O.D.) 11 ga. wall steel pipe to meet 2" nominal steel pipe size specifications, with heavy gauge steel die-formed angles for attaching/supporting seats and top. The two frame structures bolt together under the table top. Welded-on mounting plates with 9/16" dia. holes allow table to be permanently anchored to a hard surface.
- Surface mount (bolt down) installation provides a secure location. Set of (4) screw anchors for concrete surfaces are included.
- Model FCT-4 table is 4 ft. long and seats four people with walk in access to seats.
- Overall footprint of this table is 48" long x 58" wide.
- Nominal table height 29-1/2". Nominal seat height is 16-1/2".
- All fasteners are provided for assembly.
- The open span frame design of Model FCT Food Court Table creates a clear area under and around the table for easy clean up.
- **Standard:** All steel frame components are hot-dip galvanized after fabrication to ASTM-A123 to maintain an average zinc coating of 2.0 oz. per sq. ft. of surface area (indicated by "/G" in model no., e.g.. FCT/G-4FG/BLUE.)
- **Standard:** Table top and seats are made from 100% blue fiberglass material, UV coated for long-lasting color and durability (indicated by "FG/BLUE" in model no., e.g.. FCT/G-4FG/BLUE.)
- **Standard:** Table top features a 1/3/4" umbrella hole to insert an optional umbrella.
- **Optional:** Color choices of fiberglass top and seats; limited to red, blue, green, yellow.
- **Optional:** Color choices of powder coated steel frame components. For optional colors choices see Specification Bulletin #SPC-CO-001.
- **Optional:** 2-part aluminum cover caps for frame post anchor plates. Order (4) #CC-1 cover caps. Standard aluminum finish will coordinate with hot dip galvanized frame finish. Powder coat finish available to match optional frame finish colors.

AVAILABLE OPTIONS

- Powder coat frame finish in choice of colors.
- Choice of colors of fiberglass top and seats.
- Cover caps for frame posts.

RJ Thomas Mfg. Co., Inc.

PO Box 946 • Cherokee, IA 51012-0946 • PH: 712-225-5115 • 800-762-5002 • FAX: 712-225-5796
E-mail: pilotrock@rjthomas.com • Web Site: <http://www.pilotrock.com>

© 2019 RJ Thomas Mfg. Co., Inc. PILOT ROCK® Park Products is a registered trademark of RJ Thomas Mfg. Co., Inc.

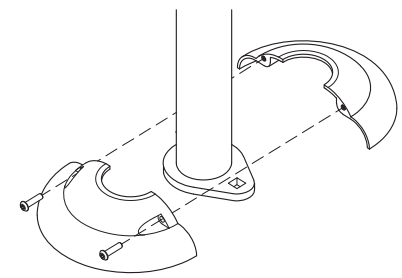
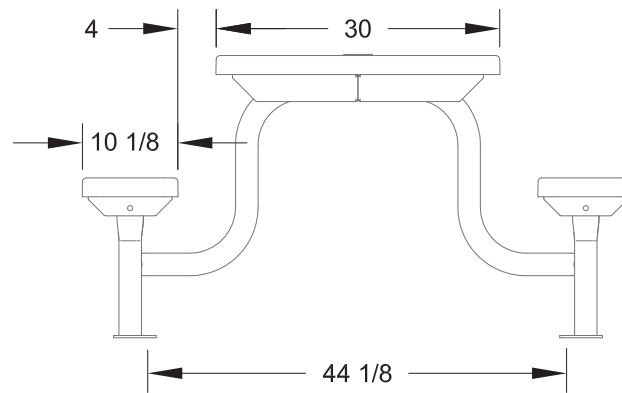
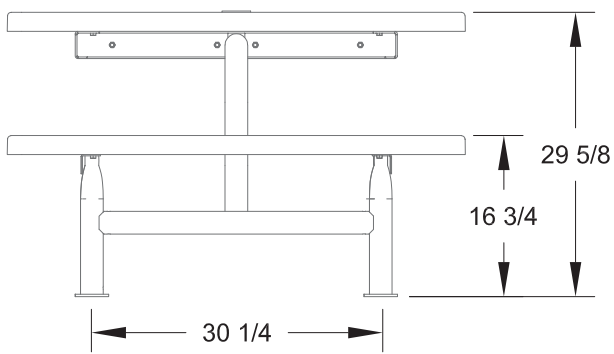
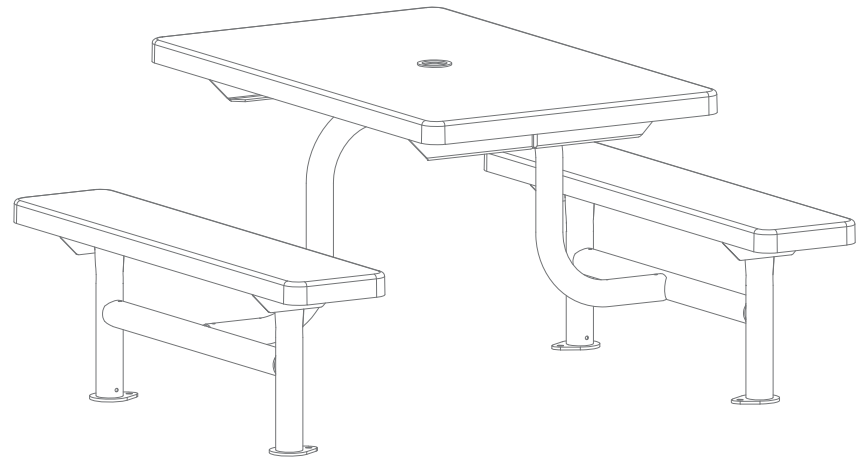
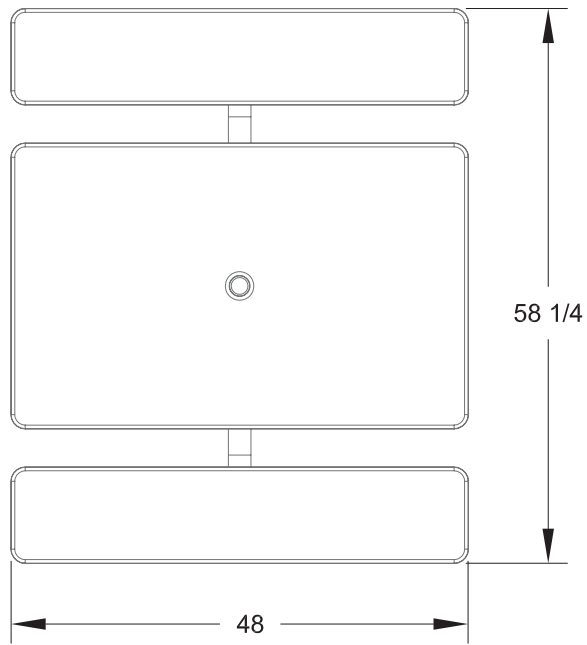

MODEL CC-1
 SURFACE INSTALLATION
 TWO-PART ALUMINUM COVER CAP

ALL DIMENSIONS IN INCHES

RJThomas Mfg. Co., Inc.
 P.O. Box 946 • Cherokee, IA 51012-0946

DRAWN BY
JGJ

TITLE MODEL FCT 4 FOOT FOOD COURT TABLE WITH FIBERGLASS TOP AND SEATS AND
 1-3/4" UMBRELLA HOLE

DATE 09-10-19

DWG. NO. **AI-3009**