



Model FS-48/11/PA Campfire Ring

- **Designed to contain large fires for group activities**
- **Flanged firering for strength and safety**
- **Single level, hinged cooking grate**
- **Grate tips back for easy fire building and cleaning**
- **Public use-type spring grips of coiled steel bar**
- **Three fire barrier heights available**
- **Pin anchors embedded in concrete footings provide permanent location**
- **“Bottomless” design installs without concrete pad**
- **Utility shelf option**
- **Quality construction throughout**

SPECIFICATIONS:

- **Model FS-48/7/PA** has a 7-3/8" high fire barrier.
- **Model FS-48/9/PA** has a 9" high fire barrier.
- **Model FS-48/11/PA** has a 11-3/8" high fire barrier.
- The 48" overall dia. ring is fabricated from 3/16" thick steel with a formed (NOT WELDED) 1" flanged lip around the top of the ring, with 9/16" draft holes spaced around the bottom perimeter.
- 290 sq. in. grate is constructed from 5/8" dia. A-36 steel bars around the perimeter, 3/4" dia. A-36 steel bar for the handle and 1/2" dia. A-36 steel bars to provide the grate surface.
- Grate is attached to and hinge upon 2 tightly formed eyelets made from 5/8" dia. A-36 steel bar that makes a mechanically secure theft-proof attachment.
- Grate tips over backward to allow unobstructed viewing of the fire by persons seated around the fire. Grate is supported by the ground when tipped back so grate cannot be vandalized.
- Grate handle is provided with two substantially constructed spring grips suitable for public use made from 1/8" x 1/2" steel flat bar.
- Ring is provided with four 1/2" dia. anchor pins for concrete embedment (indicated by /PA in model no., e.g. FS-48/7/PA).
- Entire unit is finished in high temperature, heat resistant, nontoxic black enamel paint.
- **Optional:** Firering is provided with a 3/16" x 7-1/8" x 9-5/8" steel plate utility shelf. (Add /S to model no., e.g. FS-48/7/PA/S.)

AVAILABLE OPTIONS

Utility Shelf

RJThomas Mfg. Co., Inc.

PO Box 946 • Cherokee, IA 51012-0946 • PH: 712-225-5115 • 800-762-5002 • FAX: 712-225-5796
E-mail: pilotrock@rjthomas.com • Web Site: <http://www.pilotrock.com>

© 2008 RJThomas Mfg. Co., Inc. PILOT ROCK® Park Products is a registered trademark of RJThomas Mfg. Co., Inc.

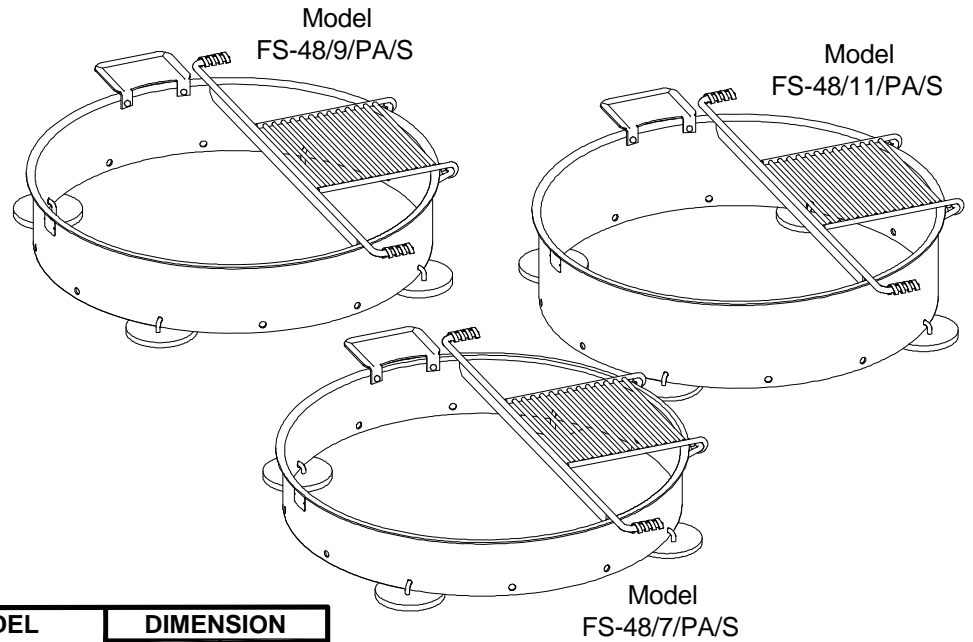
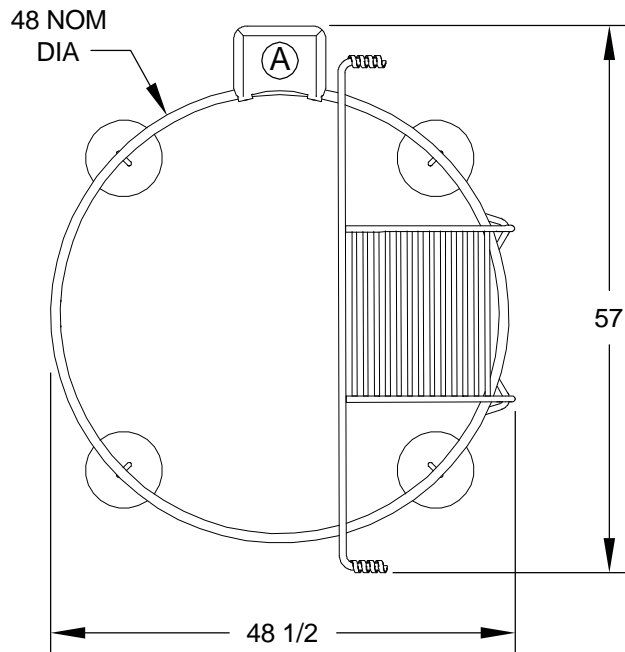

MODEL NUMBER	DIMENSION	
	a	b
FS-48/7/PA	7-3/8	8
FS-48/9/PA	9	9-5/8
FS-48/11/PA	11-3/8	12

Ⓐ OPTIONAL UTILITY SHELF - ADD /S TO MODEL NUMBER

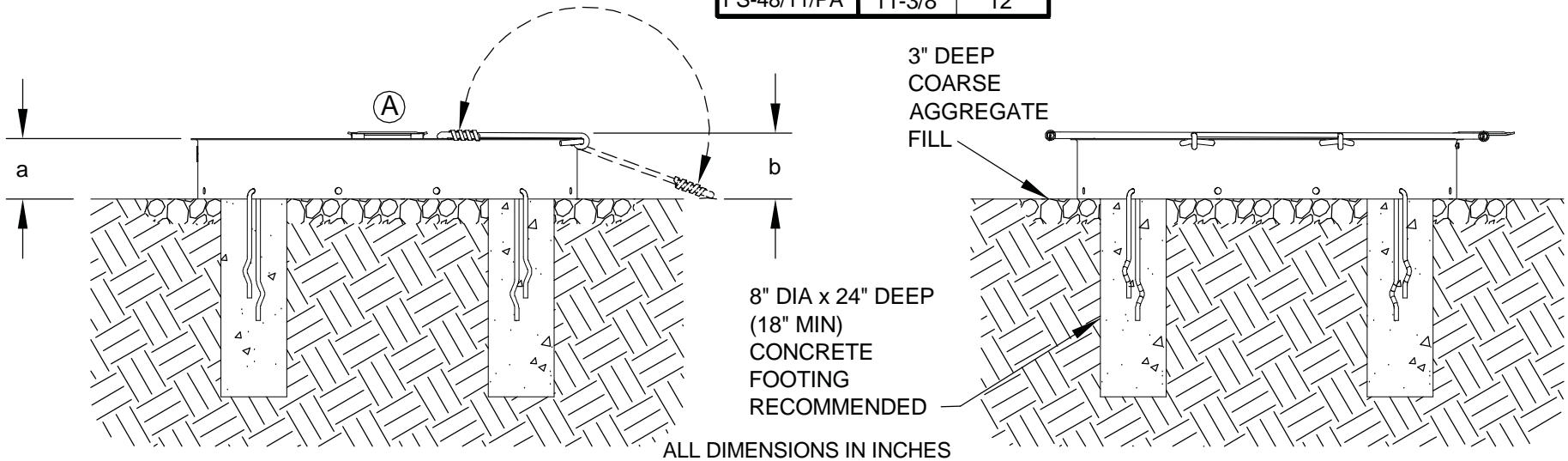

ALL DIMENSIONS IN INCHES

RJThomas Mfg. Co., Inc.
P.O. Box 946 • Cherokee, IA 51012-0946

DRAWN BY
WWM

TITLE **FS-48 SERIES CAMPFIRE RING WITH PIN ANCHORS; 3 MODELS WITH 3 SIDE HEIGHTS -SHOWN WITH OPTIONAL UTILITY SHELF**

DATE **9-22-08**

DWG. NO. **AI-1456**