



*Model UT/G-8PU Portable Rectangular Table
with Hot Dip Galvanized Frames,
8 Ft. long with Blue 2" x 10" Recycled Plastic planks.*

- **Nontip, nontrip, walk-through design**
- **All-welded end frames are fabricated from 1.660" diameter steel pipe**
- **Die-formed center channel under table top to support and align top planks**
- **Diagonal bracing for strength and rigidity**
- **Frames are hot-dip galvanized after fabrication for superior corrosion resistance**
- **100% Recycled Plastic seat and top planks with solid color and U.V. stabilizer for ultraviolet protection**
- **Steel channel reinforcements under seat and table top planks**
- **Limited Lifetime Warranty on frames**

SPECIFICATIONS:

- **UT Series** end frames are one-piece welded construction, fabricated from 1.660" O.D. x (10 ga.) wall steel pipe to meet 1-1/4" nominal pipe size specifications with 2" x 2" x 1/8" die formed steel angle for attaching the seats and top. Bends are tightly formed to prevent tipping when weight is on one side.
- Table frame design incorporates nontip, nontrip, walk-through design features.
- **Model UT/G-6** is a nom. 6 ft. in length.
- **Model UT/G-8** is a nom. 8 ft. in length.
- Nominal table height is 30". Nominal seat height is 18".
- Frames are supported by diagonal braces of 1-5/16" O.D. x 14 ga. wall steel pipe that connect to a die-formed steel channel designed to align and provide attachment to the table top.
- All fasteners are provided for assembly.
- **Standard:** All steel frame components are hot-dip galvanized after fabrication to ASTM-A123 to maintain an average zinc coating of 2.0 oz. per sq. ft. of surface area (indicated by "/G" in model no., e.g. UT/G-6PC).
- **Standard:** Top and seats are made of 100% Recycled Plastic molded into 2" x 10" nominal sized planks with solid Cedar color (indicated by "PC" in model no., e.g. UT/G-6PC) formed throughout and a U.V. stabilizer added for ultra-violet protection.
- Recycled Plastic table top and seat planks are supported by die-formed pregalvanized steel channels.
- **Optional:** Color choices of powder coated steel frame components. See Specification Bulletin #SPC-CO-001.
- **Optional:** Color choices of Recycled Plastic components. See Specification Bulletin #SPC-CO-001.

AVAILABLE OPTIONS

- 6' or 8' models
- Powder Coat Finish in choice of colors for steel frame components
- Choice of colors of Recycled Plastic

RJ Thomas Mfg. Co., Inc.

PO Box 946 • Cherokee, IA 51012-0946 • PH: 712-225-5115 • 800-762-5002 • FAX: 712-225-5796
E-mail: pilotrock@rjthomas.com • Web Site: <http://www.pilotrock.com>

© 2017 RJ Thomas Mfg. Co., Inc. PILOT ROCK® Park Products is a registered trademark of RJ Thomas Mfg. Co., Inc.

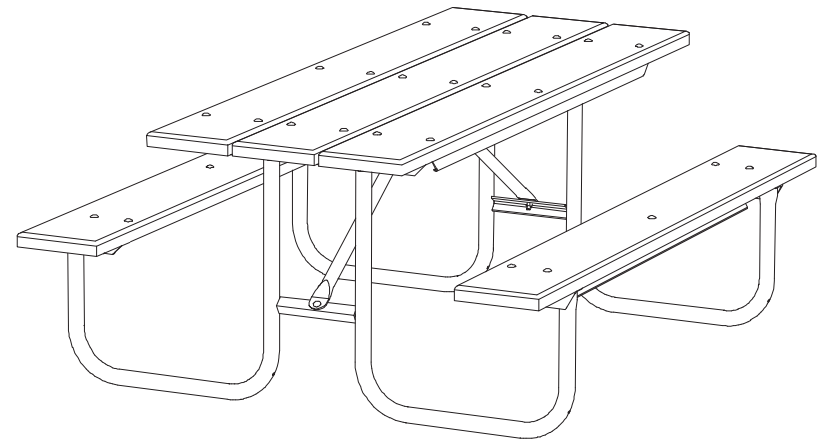
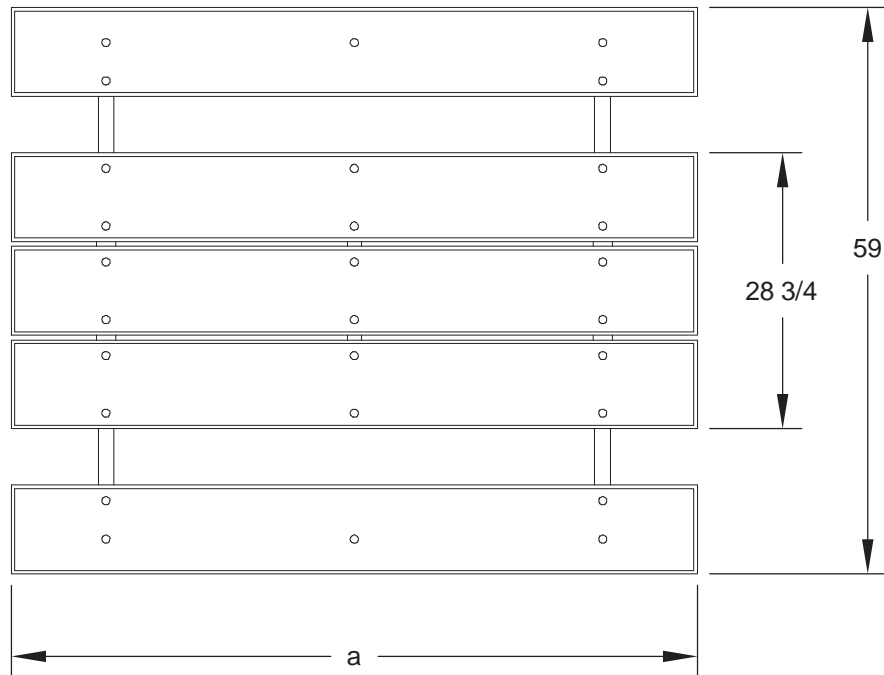

MODEL NUMBER	DIMENSION	
	a	b
UT-6	71-1/2	51-3/4
UT-8	95-1/2	70

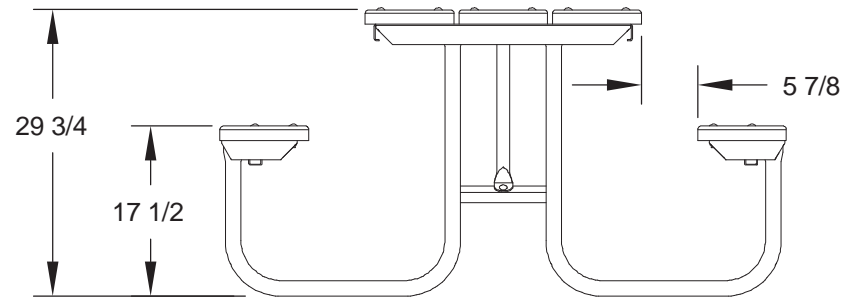
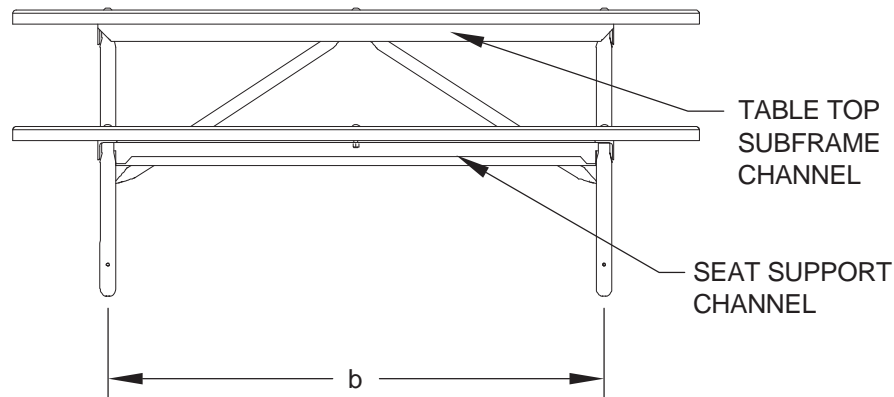

ALL DIMENSIONS IN INCHES

RJThomas Mfg. Co., Inc.
P.O. Box 946 • Cherokee, IA 51012-0946

DRAWN BY
WWM

TITLE UT SERIES 6 AND 8 FOOT PORTABLE RECTANGULAR TABLE WITH 100% RECYCLED PLASTIC TOP AND SEAT PLANKS

DATE 11-13-08

DWG. NO. AI-1622