

UT Series 10 and 12 Foot Rectangular Table with Lumber Top and Seats



*Model UT/G-10UP 10 Ft. Heavy Duty Portable Rectangular Table
with Hot Dip Galvanized Frame
and Southern Yellow Pine top and seats.*

- **Nontip, nontrip, walk-through design**
- **All welded end frames are fabricated from 1.66" diameter steel pipe**
- **Die-formed center channel and diagonal braces align and strengthen entire table**
- **Frames are hot dip galvanized after fabrication for superior corrosion resistance**
- **Precision drilled, Untreated #1 Southern Yellow Pine top and seat planks**
- **Limited lifetime warranty on frames**

SPECIFICATIONS:

- **UT Series** end frames are one-piece welded construction, fabricated from 1.660" O.D. (1-5/8" O.D.) steel pipe to meet 1-1/4" nominal pipe size specifications with 2" x 2" x 1/8" die formed steel angle for attaching the seats and tops.
- Table frame design incorporates nontip, nontrip, walk-through design features.
- **Model UT/G-10UP** is a nominal 10 ft. long with three frames.
- **Model UT/G-12UP** is a nominal 12 ft. long with three frames.
- Nominal table height, 30". Nominal seat height, 18".
- Frames are supported by diagonal braces of 1-5/16" O.D. x 14 ga. wall steel pipe that connect to a die-formed steel channel designed to align and provide attachment to the table top.
- **Standard:** All steel frame components are hot-dip galvanized after fabrication to ASTM-A123 to maintain an average zinc coating of 2.0 oz. per sq. ft. of surface area (indicated by "/G" in model no., e.g. UT/G-10UP).
- All galvanized fasteners are provided for assembly.
- **Standard:** Lumber is Untreated #1 grade Southern Yellow Pine (indicated by "UP" in model no., e.g. UT/G-10UP) 2" x 10" nominal sized planks, kiln dried to reduce moisture content. All lumber is precision drilled to facilitate assembly and has all exposed edges removed to a 3/8" radius.
- **Optional:** All steel frame components have powder coat finish. See Specification Bulletin #SPC-CO-001.
- **Optional:** Treated #1 Southern Yellow Pine is readily available and is pressure treated (KDAT) to preserve wood against decay. To specify, change "UP" in model no. to "TP", e.g. UT/G-6TP. (Cedar, Fir and Redwood are available when in stock -please inquire.)

AVAILABLE OPTIONS

- **10' or 12' length**
- **Powder Coat Finish in choice of colors on steel frame components**
- **Pressure treated #1 Southern Yellow Pine lumber (Cedar, Fir, or Redwood lumber when in stock)**

RJ Thomas Mfg. Co., Inc.

PO Box 946 • Cherokee, IA 51012-0946 • PH: 712-225-5115 • 800-762-5002 • FAX: 712-225-5796
E-mail: pilotrock@rjthomas.com • Web Site: <http://www.pilotrock.com>

© 2017 RJ Thomas Mfg. Co., Inc. PILOT ROCK® Park Products is a registered trademark of RJ Thomas Mfg. Co., Inc.

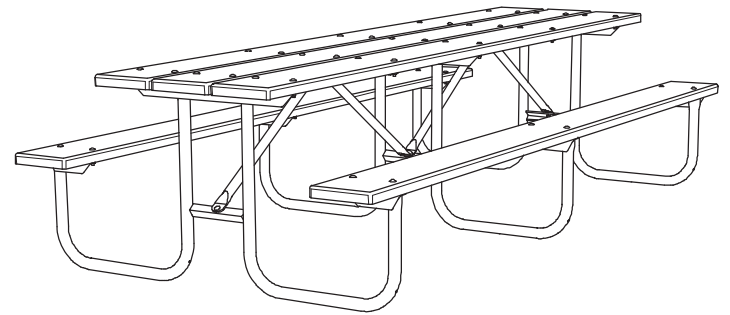
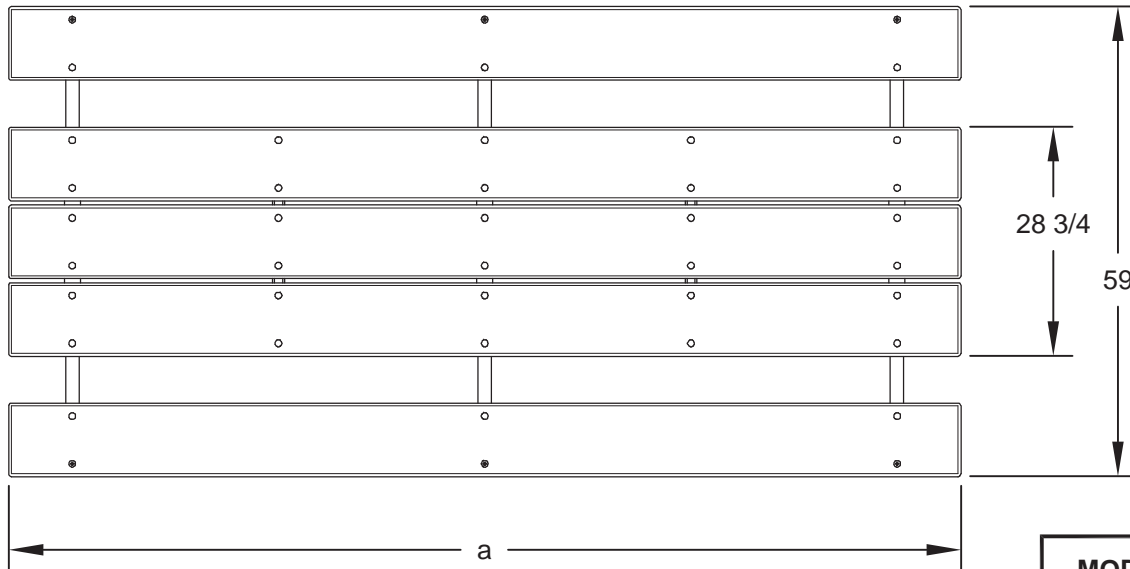

MODEL NUMBER	DIMENSION	
	a	b
UT-10	119 1/2	51 3/4
UT-12	143 1/2	60 7/8

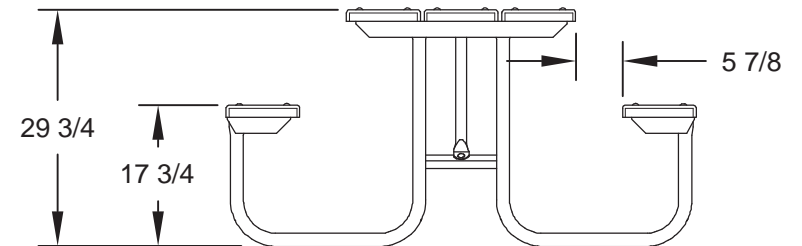
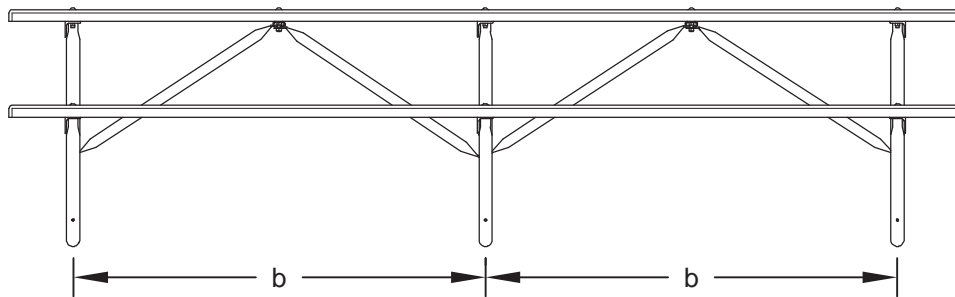

ALL DIMENSIONS IN INCHES

RJThomas Mfg. Co., Inc.
P.O. Box 946 • Cherokee, IA 51012-0946

DRAWN BY
WWM

TITLE UT SERIES HEAVY DUTY 10 AND 12 FOOT PORTABLE RECTANGULAR TABLE WITH LUMBER TOP AND SEATS

DATE 11-17-08

DWG. NO. AI-1844