



*Model WUT/G-10AL Accessible Rectangular Table
with hot dip Galvanized frames, 10 ft. long
with Clear Anodized Aluminum top and seats.*

- **Strong 1-5/8" diameter all welded, steel pipe end frame construction**
- **Nontip, nontrip, walk-through design with wheelchair accessibility at each end**
- **Full capacity seating when wheelchairs are not in place**
- **Frames are hot-dip galvanized after fabrication for superior corrosion resistance**
- **Structurally reinforced extruded Aluminum Top and Seats with clear anodized finish**
- **Two die-formed center channels under table top to support and align top planks**
- **Diagonal bracing for strength and rigidity**
- **Quality construction throughout**
- **Limited Lifetime Warranty on frames**

AVAILABLE OPTIONS

10 or 12 foot lengths

Choice of colors of Powder Coat Finish on steel frame components

Choice of colors of Powder Coat Finish on aluminum top and seats

SPECIFICATIONS:

- **WUT Series** end frames are one-piece welded construction, fabricated from 1.66" OD x 10 ga. wall steel pipe to meet 1-1/4" nominal steel pipe size specifications with 2" x 2" x 1/8" die-formed steel angle for attaching the top and seats. Bends are tightly formed to prevent tipping when weight is on one side.
- The frame design provides the ADA recommended wheelchair clearance under the table top of : 30" wide, 27" high, and 24" total knee and toe clearance (19" knee + 5" toe) at each end of the table while maintaining the full seating capacity of the table for common use.
- Table frame incorporates nontip, nontrip, walk-through design features.
- **Model WUT/G-10** has a nom. 10 ft. length with three frames.
- **Model WUT/G-12** has a nom. 12 ft. length with three frames.
- Nominal table height is 30". Frame design provides a nominal 28" of clearance from ground level to the underside of table. Nominal seat height is 18".
- Frames are supported by diagonal braces of 1-5/16" OD x 14 ga. wall steel pipe that connect to die-formed steel channels designed to align and provide attachment to the table top.
- All galvanized fasteners are provided for assembly.
- **Standard:** All steel frame components are hot-dip galvanized after fabrication to ASTM-A123 to maintain an average zinc coating of 2.0 oz. per sq. ft. of surface area (indicated by "/G" in model no., e.g. WUT/G-10AL).
- Aluminum is extruded 6063-T6 aluminum alloy in planks with dimensions equivalent to that of 2" x 10" nominal sized lumber. The plank design is 1-3/4" x 9-5/8" with four structural reinforcement ribs for greater rigidity. Aluminum planks are provided with a clear anodized finish as per anodizing specification 204 R1. Aluminum clips to fasten planks to frames are included.
- Channel end caps are of extruded 6063-T6 aluminum alloy provided with a clear anodized finish as per anodizing specification 204 R1. End caps are press fitted over ends of aluminum planks and mechanically fastened in place at the factory.
- Table tops are assembled into single units at the factory with one-piece end caps across each end.
- **Optional:** All steel frame components have powder coat finish. See Specification Bulletin #SPC-CO-001.
- **Optional:** Aluminum top and seat planks and end caps have powder coat finish. See Specification Bulletin #SPC-CO-001.
- **U.S. Patent Nos. D489,539; D490,992; D493,291; D496,799; D497,262; 6,918,630**

RJ Thomas Mfg. Co., Inc.

PO Box 946 • Cherokee, IA 51012-0946 • PH: 712-225-5115 • 800-762-5002 • FAX: 712-225-5796
E-mail: pilotrock@rjthomas.com • Web Site: <http://www.pilotrock.com>

© 2017 RJ Thomas Mfg. Co., Inc. PILOT ROCK[®] Park Products is a registered trademark of RJ Thomas Mfg. Co., Inc.

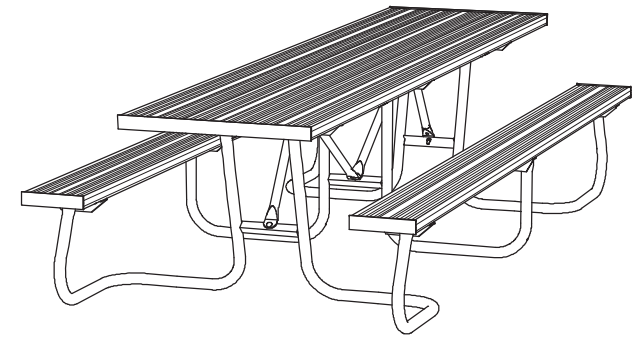
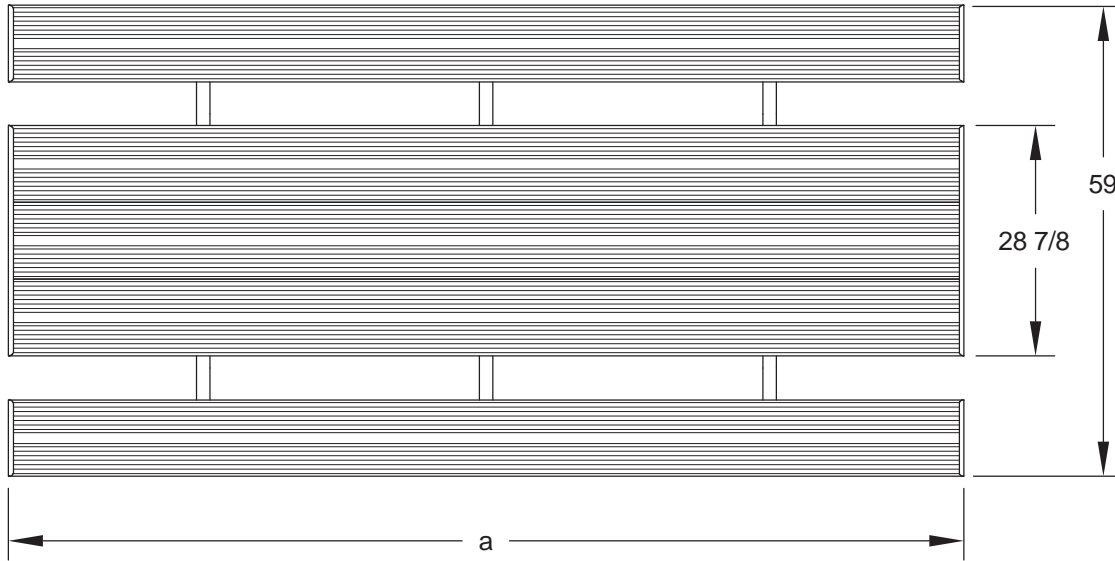

MODEL	DIMENSION	
	a	b
WUT-10	120	35 1/2
WUT12	144	45 5/8

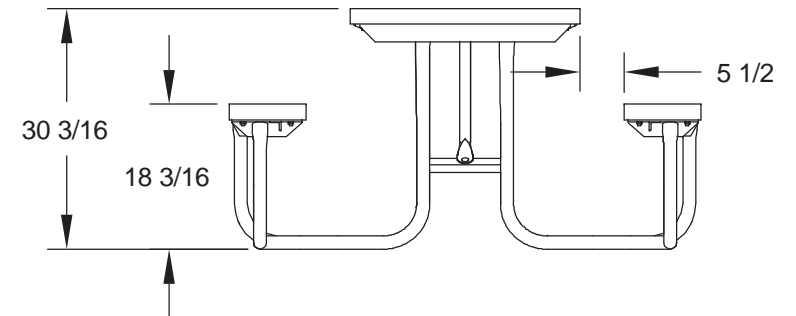
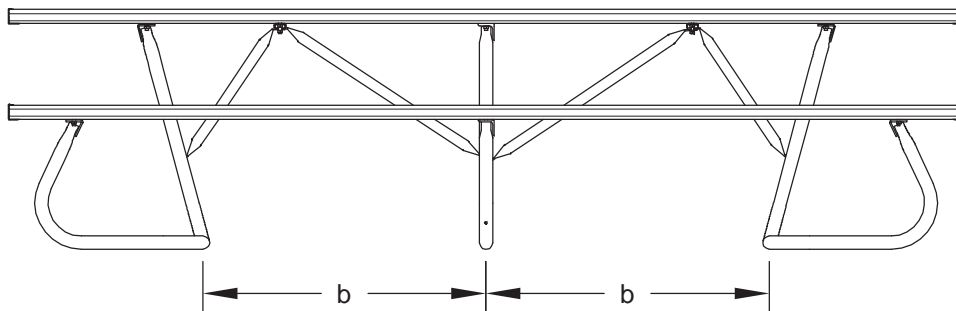

ALL DIMENSIONS IN INCHES

RJThomas Mfg. Co., Inc.
P.O. Box 946 • Cherokee, IA 51012-0946

DRAWN BY
WWM

TITLE WUT SERIES 10 AND 12 FOOT UNIVERSAL ACCESSIBLE RECTANGULAR TABLE
WITH ALUMINUM TOP AND SEATS

DATE 3-24-09

DWG. NO. **AI-1873**