



*Model WUT/G-10UP Universal Accessible Rectangular Table with hot dip Galvanized frames, 10 ft. long with Untreated Pine top and seats.*

- **Strong 1-5/8" diameter all welded, steel pipe end frame construction**
- **Nontip, nontrip, walk-through design with wheelchair accessibility at each end**
- **Full capacity seating when wheelchairs are not in place**
- **Frames are hot-dip galvanized after fabrication for superior corrosion resistance**
- **Precision drilled, Untreated #1 Southern Yellow Pine Top and seat Planks**
- **Two die-formed center channels under table top to support and align top planks**
- **Diagonal bracing for strength and rigidity**
- **Quality construction throughout**
- **Limited Lifetime Warranty on frames**

#### **AVAILABLE OPTIONS**

**10 or 12 foot lengths**

**Choice of colors of Powder Coat Finish on steel frame components**

**Pressure treated #1 Southern Yellow Pine lumber (Cedar, Fir, or Redwood lumber when in stock)**

#### **SPECIFICATIONS:**

- **WUT Series** end frames are one-piece welded construction, fabricated from 1.66" OD x 10 ga. wall steel pipe to meet 1-1/4" nominal steel pipe size specifications with 2" x 2" x 1/8" die-formed steel angle for attaching the top and seats. Bends are tightly formed to prevent tipping when weight is on one side.
- The frame design provides the ADA recommended wheelchair clearance under the table top of : 30" wide, 27" high, and 24" total knee and toe clearance (19" knee + 5" toe) at each end of the table while maintaining the full seating capacity of the table for common use.
- Table frame incorporates nontip, nontrip, walk-through design features.
- **Model WUT/G-10** has a nom. 10 ft. length with three frames.
- **Model WUT/G-12** has a nom. 12 ft. length with three frames.
- Nominal table height is 30". Frame design provides a nominal 28" of clearance from ground level to the underside of table. Nominal seat height is 18".
- Frames are supported by diagonal braces of 1-5/16" OD x 14 ga. wall steel pipe that connect to die-formed steel channels designed to align and provide attachment to the table top.
- All galvanized fasteners are provided for assembly.
- **Standard:** All steel frame components are hot-dip galvanized after fabrication to ASTM-A123 to maintain an average zinc coating of 2.0 oz. per sq. ft. of surface area (indicated by "/G" in model no., e.g. WUT/G-10UP).
- **Standard:** Lumber is Untreated #1 grade Southern Yellow Pine (indicated by "UP" in model no., e.g. WUT/G-10UP) 2" x 10" nominal sized planks, kiln dried to reduce moisture content. All lumber is precision drilled to facilitate assembly and has all exposed edges removed to a 3/8" radius.
- Two 1-5/8" x 1-5/16" x 14 ga. x 28" pregalvanized steel end caps are provided to align ends of top planks.
- **Optional:** All steel frame components have powder coat finish. See Specification Bulletin #SPC-CO-001.
- **Optional:** Treated #1 Southern Yellow Pine is readily available and is pressure treated (KDAT) to preserve wood against decay. To specify, change "UP" in model no. to "TP", e.g. WUT/G-10TP. (Cedar, Fir and Redwood are available when in stock –please inquire.)
- **U.S. Patent Nos. D489,539; D490,992; D493,291; D496,799; D497,262; 6,918,630**

**RJ Thomas Mfg. Co., Inc.**

PO Box 946 • Cherokee, IA 51012-0946 • PH: 712-225-5115 • 800-762-5002 • FAX: 712-225-5796  
E-mail: pilotrock@rjthomas.com • Web Site: <http://www.pilotrock.com>

© 2017 RJ Thomas Mfg. Co., Inc. PILOT ROCK<sup>®</sup> Park Products is a registered trademark of RJ Thomas Mfg. Co., Inc.

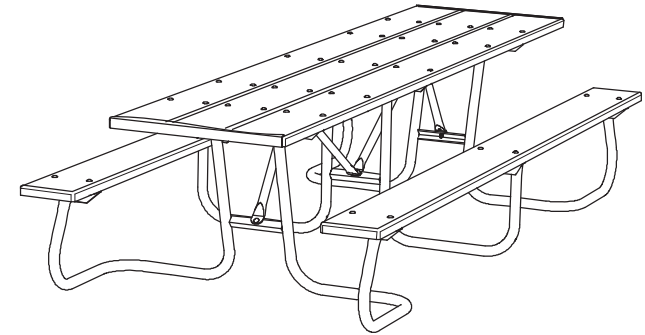
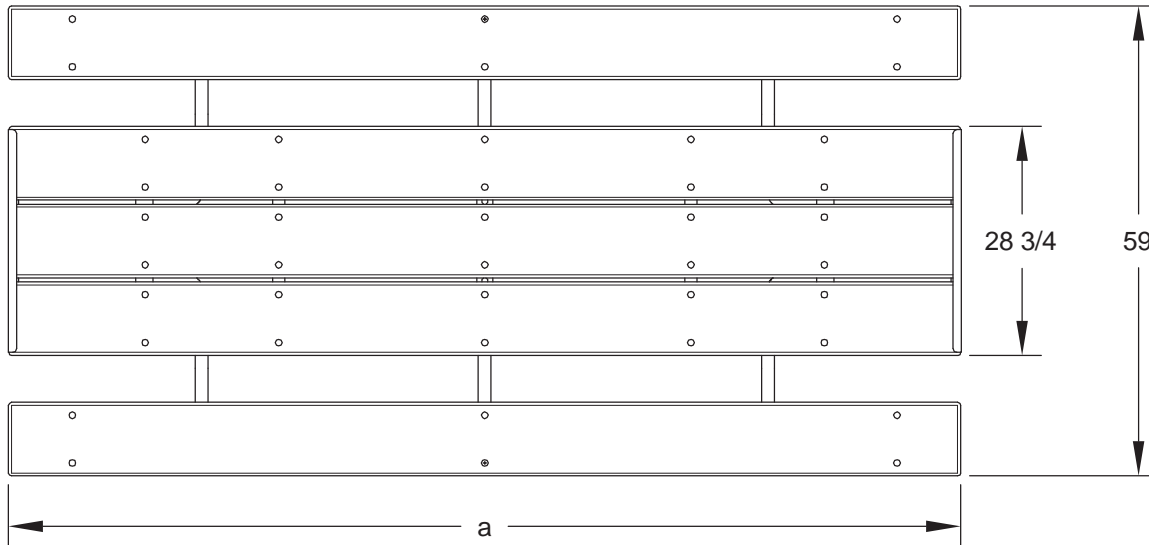

MODEL	DIMENSION	
	a	b
WUT-10	119 1/2	35 1/2
WUT-12	143 1/2	44 5/8

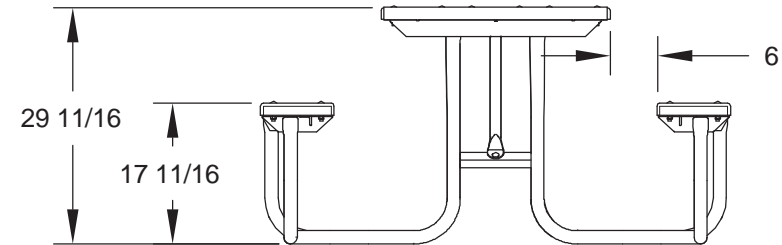
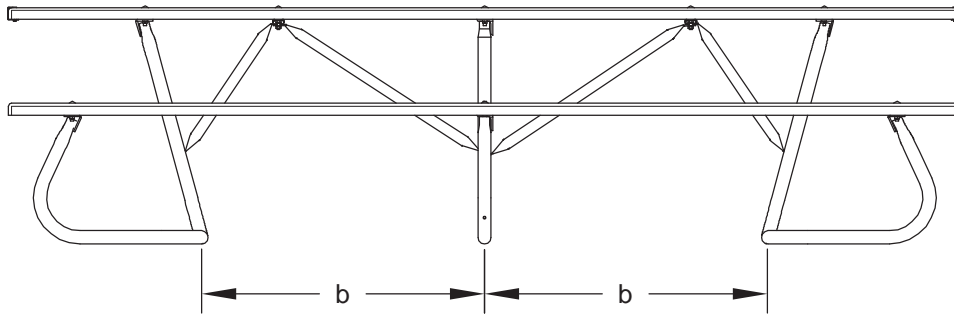

ALL DIMENSIONS IN INCHES

**RJThomas Mfg. Co., Inc.**  
P.O. Box 946 • Cherokee, IA 51012-0946

DRAWN BY  
**WWM**

TITLE **WUT SERIES 10 AND 12 FOOT UNIVERSAL ACCESSIBLE RECTANGULAR TABLE  
WITH LUMBER TOP AND SEATS**

DATE **3-23-09**

DWG. NO. **AI-1871**