



*Model WUT/CR-6PY 6 Ft. Portable, Universal Accessible
Rectangular Table with Red Powder Coated Frames
and Yellow Recycled Plastic top and seats*

- **Strong 1-5/8" diameter all welded, steel pipe end frame construction**
- **Nontip, nontrip, walk-through design with wheelchair accessibility at each end**
- **Full capacity seating when wheelchairs are not in place**
- **Frames are hot-dip galvanized after fabrication for superior corrosion resistance**
- **Die-formed center channel under table top to support and align top planks**
- **Diagonal bracing for strength and rigidity**
- **100% Recycled Plastic Seat and Top Planks with solid color and U.V. stabilizer for ultraviolet protection**
- **Steel channel reinforcements under seats and table top**
- **Quality construction throughout**
- **Limited Lifetime Warranty on frames**

AVAILABLE OPTIONS

- **6 or 8 foot lengths**
- **Choice of colors of Powder Coat Finish on steel frame components**
- **Choice of colors of Recycled Plastic**

SPECIFICATIONS:

- **WUT Series** end frames are one-piece welded construction, fabricated from 1.66" OD x 10 ga. wall steel pipe to meet 1-1/4" nominal steel pipe size specifications with 2" x 2" x 1/8" die-formed steel angle for attaching the top and seats. Bends are tightly formed to prevent tipping when weight is on one side.
- The frame design provides the ADA recommended wheelchair clearance under the table top of: 30" wide, 27" high, and 24" total knee and toe clearance (19" knee + 5" toe) at each end of the table while maintaining the full seating capacity of the table for common use.
- Table frame incorporates nontip, nontrip, walk-through design features.
- **Model WUT/G-6** has a nom. 6 ft. length.
- **Model WUT/G-8** has a nom. 8 ft. length.
- Nominal table height is 30". Frame design provides a nominal 28" of clearance from ground level to the underside of table. Nominal seat height is 18".
- Frames are supported by diagonal braces of 1-5/16" OD x 14 ga. wall steel pipe that connect to a die-formed steel channel designed to align and provide attachment to the table top.
- All galvanized fasteners are provided for assembly.
- **Standard:** All steel frame components are hot-dip galvanized after fabrication to ASTM-A123 to maintain an average zinc coating of 2.0 oz. per sq. ft. of surface area (indicated by "/G" in model no., e.g. WUT/G-6PW).
- **Standard:** Top and seats are made of 100% Recycled Plastic molded into 2" x 10" nominal sized planks with solid Brown color (indicated by PW in model no., e.g. WUT/G-6PW) formed throughout and a U.V. stabilizer added for ultra-violet protection.
- Recycled Plastic table top and seat planks are supported by pregalvanized steel subframe channels.
- **Optional:** All steel frame components have powder coat finish. See Specification Bulletin #SPC-CO-001.
- **Optional:** Color choices of Recycled Plastic components. See Specification Bulletin #SPC-CO-001.
- **U.S. Patent Nos. D489,539; D490,992; D493,291; D496,799; D497,262; 6,918,630**

RJ Thomas Mfg. Co., Inc.

PO Box 946 • Cherokee, IA 51012-0946 • PH: 712-225-5115 • 800-762-5002 • FAX: 712-225-5796
E-mail: pilotrock@rjthomas.com • Web Site: <http://www.pilotrock.com>

© 2017 RJ Thomas Mfg. Co., Inc. PILOT ROCK® Park Products is a registered trademark of RJ Thomas Mfg. Co., Inc.

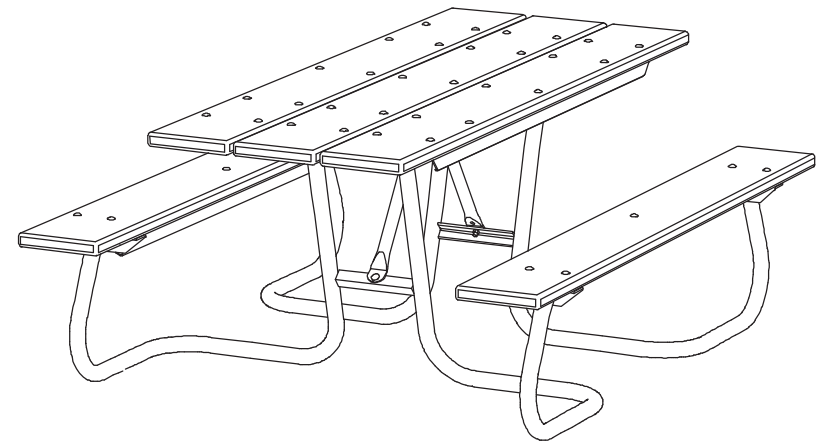
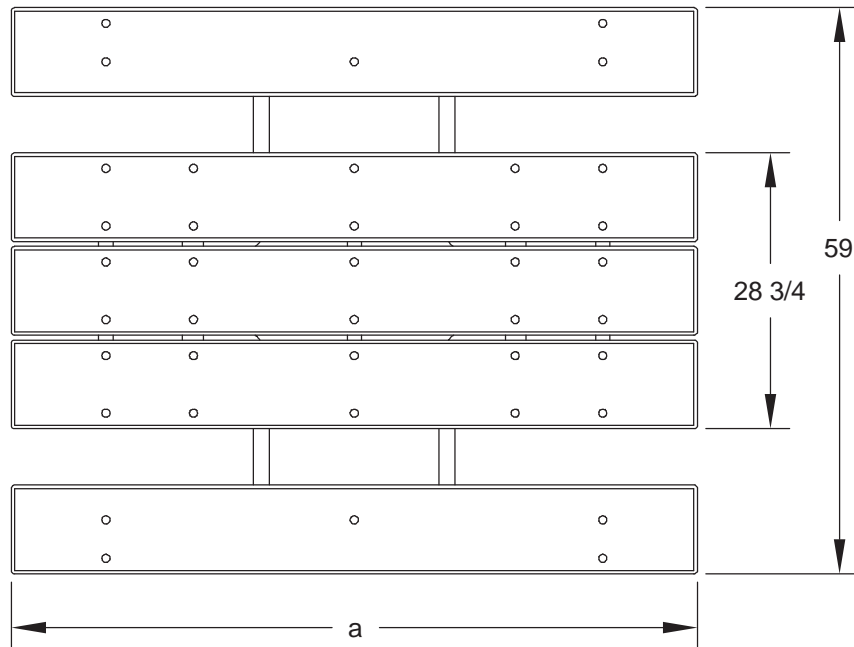

MODEL NUMBER	DIMENSION	
	a	b
WUT-6	71-1/2	19-3/8
WUT-8	95-1/2	37-5/8

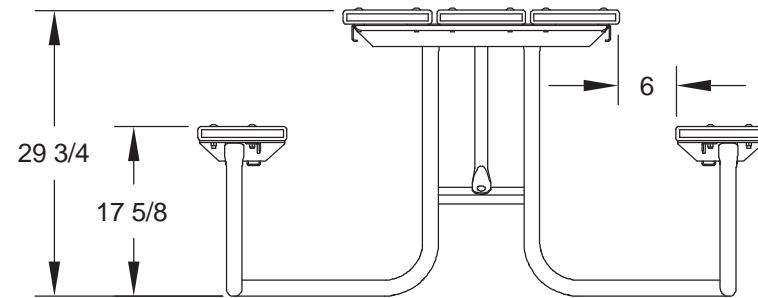
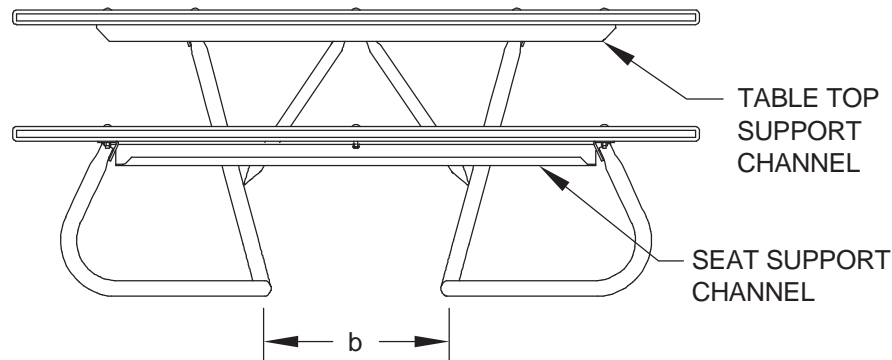

ALL DIMENSIONS IN INCHES

RJThomas Mfg. Co., Inc.
P.O. Box 946 • Cherokee, IA 51012-0946

DRAWN BY
WWM

TITLE MODEL WUT 6 AND 8 FOOT UNIVERSAL ACCESSIBLE RECTANGULAR TABLE WITH RECYCLED PLASTIC TOP AND SEATS

DATE 11-20-08

DWG. NO. AI-1788