



*Model WUTH/CE-10AU Accessible Rectangular Raised Top Table  
with Burgundy powder coated frames, 10 ft. long  
with Blue powder coated Aluminum top and seats.*

- **Raised table top for greater wheelchair clearance**
- **Strong 1-5/8" diameter all welded, steel pipe end frame construction**
- **Nontip, nontrip, walk-through design with wheelchair accessibility at each end**
- **Full capacity seating when wheelchairs are not in place**
- **Frames are hot-dip galvanized after fabrication for superior corrosion resistance**
- **Structurally reinforced extruded Aluminum Top and Seats with clear anodized finish**
- **Die-formed center channel under table top to support and align top planks**
- **Diagonal bracing for strength and rigidity**
- **Quality construction throughout**
- **Limited Lifetime Warranty on frames**

#### **AVAILABLE OPTIONS**

**10 or 12 foot lengths**

**Choice of colors of Powder Coat Finish on steel frame components**

**Choice of colors of Powder Coat Finish on Aluminum top and seats**

#### **SPECIFICATIONS:**

- **WUTH Series** end frames are one-piece welded construction, fabricated from 1.66" OD x 10 ga. wall steel pipe to meet 1-1/4" nominal steel pipe size specifications with 2" x 2" x 1/8" die-formed steel angle for attaching the top and seats. Bends are tightly formed to prevent tipping when weight is on one side.
- The frame design provides the ADA recommended wheelchair clearance under the table top of: 30" wide, 27" high, and 24" total knee and toe clearance (19" knee + 5" toe) at each end of the table while maintaining the full seating capacity of the table for common use.
- Table frame incorporates nontip, nontrip, walk-through design features.
- **Model WUTH/G-10AL** has a nom. 10 ft. length with three frames.
- **Model WUTH/G-12AL** has a nom. 12 ft. length with three frames.
- Nominal table height is 33". Frame design provides a nominal 31" of clearance from ground level to the underside of table. Nominal seat height is 19".
- Frames are supported by diagonal braces of 1-5/16" OD x 14 ga. wall steel pipe that connect to a die-formed steel channel designed to align and provide attachment to the table top.
- All galvanized fasteners are provided for assembly.
- **Standard:** All steel frame components are hot-dip galvanized after fabrication to ASTM-A123 to maintain an average zinc coating of 2.0 oz. per sq. ft. of surface area (indicated by "/G" in model no., e.g. WUTH/G-10AL).
- Aluminum is extruded 6063-T6 aluminum alloy in planks with dimensions equivalent to that of 2" x 10" nominal sized lumber. The plank design is 1-3/4" x 9-5/8" with four structural reinforcement ribs for greater rigidity. Aluminum planks are provided with a clear anodized finish as per anodizing specification 204 R1. Aluminum clips to fasten planks to frames are included.
- Channel end caps are of extruded 6063-T6 aluminum alloy provided with a clear anodized finish as per anodizing specification 204 R1. End caps are press fitted over ends of aluminum planks and mechanically fastened in place at the factory.
- Table tops are assembled into single units at the factory with one-piece end caps across each end.
- **Optional:** All steel frame components have powder coat finish. See Specification Bulletin #SPC-CO-001.
- **Optional:** Aluminum top and seats have powder coat finish. See Specification Bulletin #SPC-CO-001.
- **U.S. Patent Nos. D489,539; D490,992; D493,291; D496,799; D497,262; 6,918,630**

**RJ Thomas Mfg. Co., Inc.**

PO Box 946 • Cherokee, IA 51012-0946 • PH: 712-225-5115 • 800-762-5002 • FAX: 712-225-5796  
E-mail: pilotrock@rjthomas.com • Web Site: <http://www.pilotrock.com>

© 2017 RJ Thomas Mfg. Co., Inc. PILOT ROCK® Park Products is a registered trademark of RJ Thomas Mfg. Co., Inc.

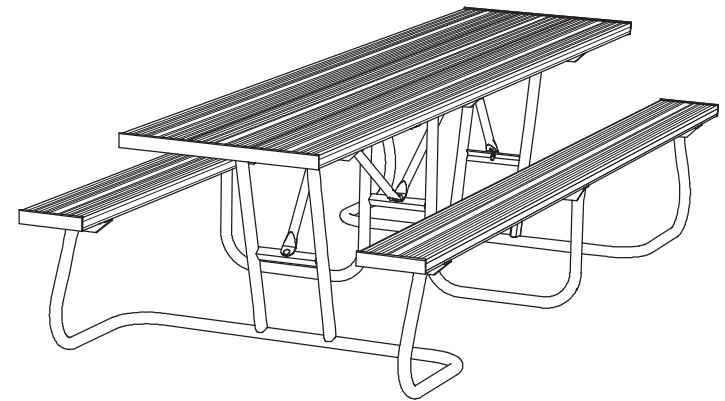
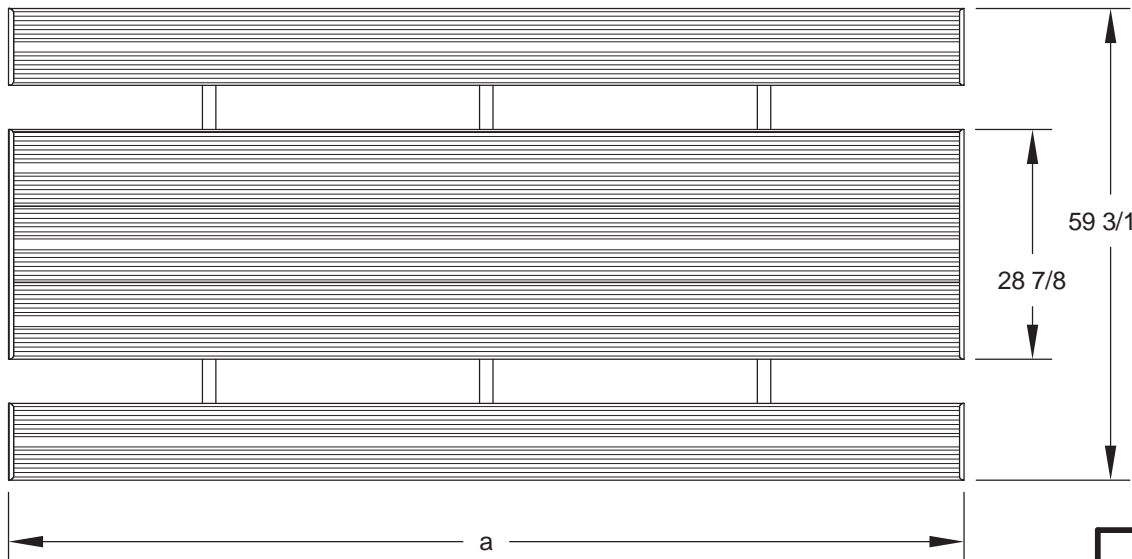

MODEL	DIMENSION	
	a	b
WUTH-10	120	34 7/8
WUTH-12	144	53 1/4

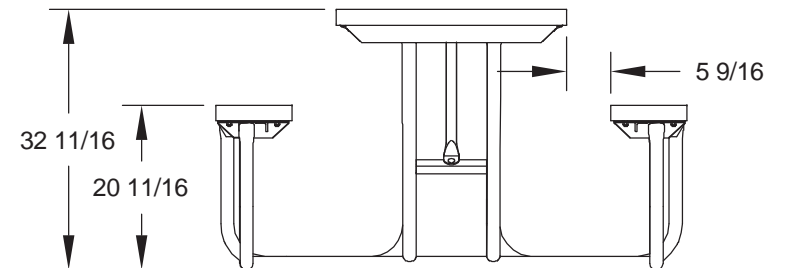
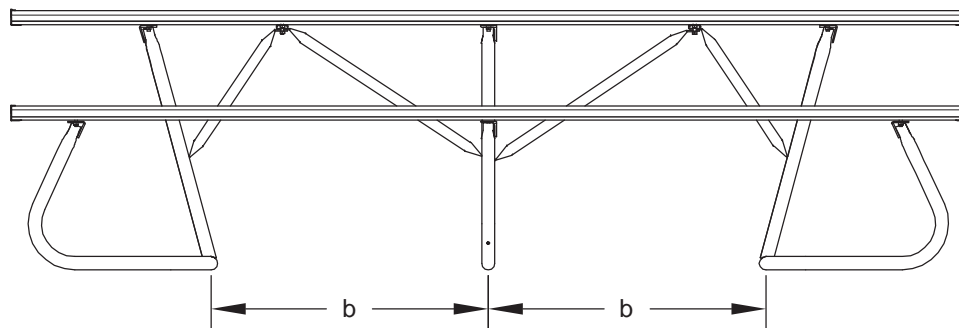

ALL DIMENSIONS IN INCHES

**RJThomas Mfg. Co., Inc.**  
P.O. Box 946 • Cherokee, IA 51012-0946

DRAWN BY  
**WWM**

TITLE **WUTH SERIES 10 AND 12 FOOT UNIVERSAL ACCESS RECTANGULAR RAISED TOP  
TABLE WITH ALUMINUM TOP AND SEATS**

DATE **4-03-09**

DWG. NO. **AI-1881**