

WXTH Series Raised Top 6 and 8 Foot Universal Access Table with Aluminum Top and Seats



*Model WXTH/G-8AL Portable Universal Access Rectangular Table
with Hot-Dip Galvanized Frames,
8 Ft. long with 2" x 10" Aluminum top and seats.*

- **Constructed specifically for heavy use areas**
- **Raised table top for greater wheelchair clearance**
- **Nontip, nontrip, walk-through design with wheelchair access at both ends**
- **All-welded end frames are fabricated from 2-3/8" diameter steel pipe**
- **Die-formed center channel under table top to support and align top**
- **Diagonal bracing for strength and rigidity**
- **Frames are hot-dip galvanized after fabrication for superior corrosion resistance**
- **Structurally reinforced extruded Aluminum Top and Seats with clear anodized finish**
- **Limited Lifetime Warranty on frames**

AVAILABLE OPTIONS

6' or 8' models

Powder Coat Finish in choice of colors on steel frame components

Powder Coat Finish in choice of colors on Aluminum top and seats

SPECIFICATIONS:

- **WXTH Series** end frames are one-piece welded construction, fabricated from 2.375" (2-3/8") O.D. x 10 ga. wall steel pipe to meet 2" nominal steel pipe size specifications with 2" x 2" x 1/8" die-formed steel angle for attaching the seats and top. Bends are tightly formed to prevent tipping when weight is on one side.
- The frame design exceeds the ADA recommended wheelchair clearances under the table top of: 30" wide, 27" high and 24" total knee and toe clearance (19" knee + 5" toe) at each end of the table while maintaining the full seating capacity of the table for common use.
- Table frame design incorporates nontip, nontrip, walk-through design features.
- **Model WXTH/G-6AL** has a nom. 6 ft. long top and 5-1/2 ft. long seats.
- **Model WXTH/G-8AL** has a nom. 8 ft. in length.
- Nominal table height is 33". Frame design provides a nominal 31" of clearance from ground level to the underside of table. Nominal seat height is 19".
- Frames are supported by diagonal braces of 1-5/16" O.D. x 14 ga. wall steel pipe that connect to a die-formed steel channel designed to align and provide attachment to the table top.
- All fasteners are provided for assembly.
- **Standard:** All steel frame components are hot-dip galvanized after fabrication to ASTM-A123 to maintain an average zinc coating of 2.0 oz. per sq. ft. of surface area (indicated by "/G" in model no., e.g. WXTH/G-6AL).
- Aluminum is extruded 6063-T6 aluminum alloy in planks with dimensions equivalent to that of 2" x 10" nominal sized lumber. The plank design is 1-3/4" x 9-5/8" with four structural reinforcement ribs for greater rigidity. Aluminum planks are provided with a clear anodized finish as per anodizing specification 204 R1. Aluminum clips to fasten planks to frames are included.
- Channel end caps are of extruded 6063-T6 aluminum alloy provided with a clear anodized finish as per anodizing specification 204 R1. End caps are press fitted over ends of aluminum planks and mechanically fastened in place at the factory.
- Table top is assembled into single unit at the factory with one-piece end caps across each end.
- **Optional:** All steel frame components have powder coat finish. See Specification Bulletin #SPC-CO-001.
- **U.S. Patent Nos. D489,539; D490,992; D493,291; D496,799; D497,262; 6,918,630**

RJ Thomas Mfg. Co., Inc.

PO Box 946 • Cherokee, IA 51012-0946 • PH: 712-225-5115 • 800-762-5002 • FAX: 712-225-5796
E-mail: pilotrock@rjthomas.com • Web Site: <http://www.pilotrock.com>

© 2017 RJ Thomas Mfg. Co., Inc. PILOT ROCK® Park Products is a registered trademark of RJ Thomas Mfg. Co., Inc.

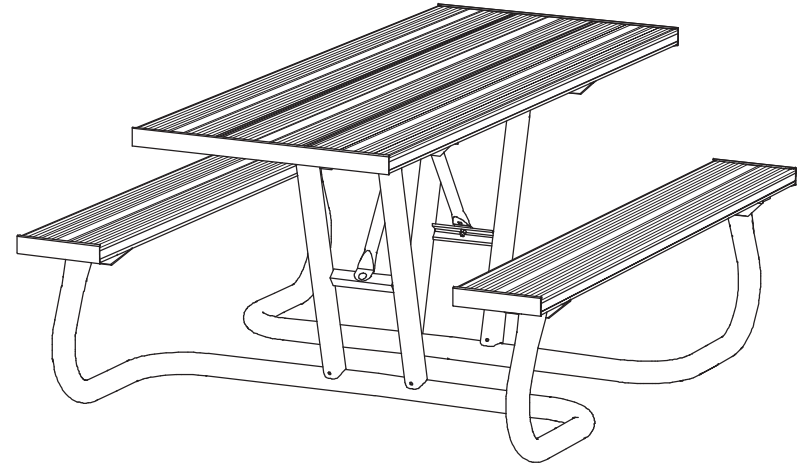
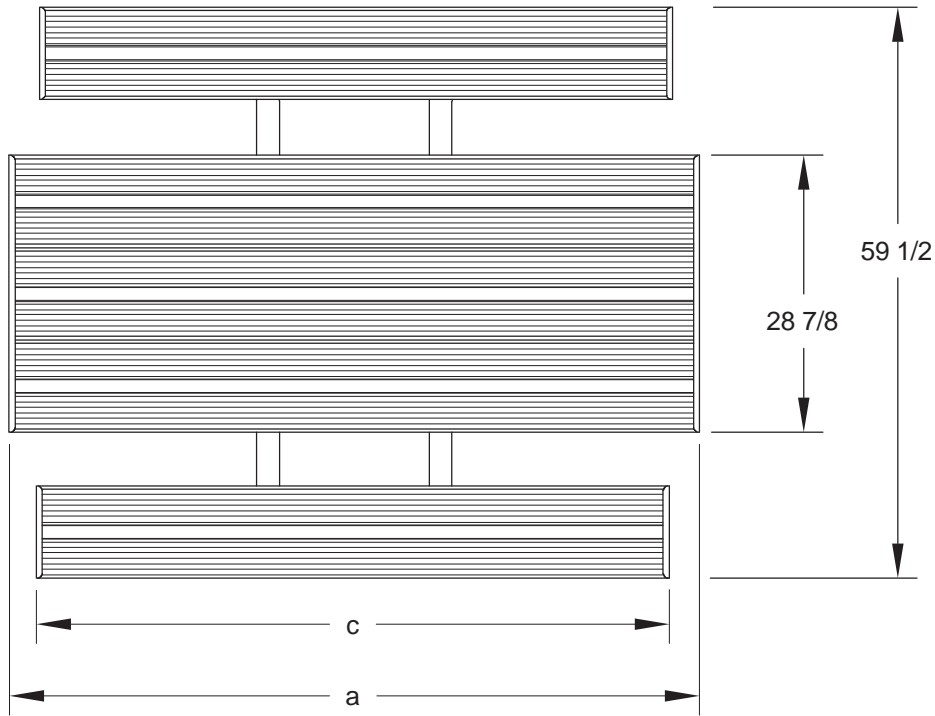

MODEL NUMBER	DIMENSION		
	a	b	c
WXTH-6	72	19	66
WXTH-8	96	36-3/16	96

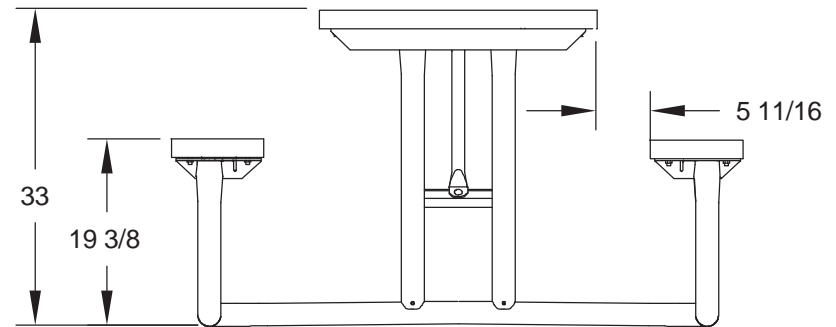
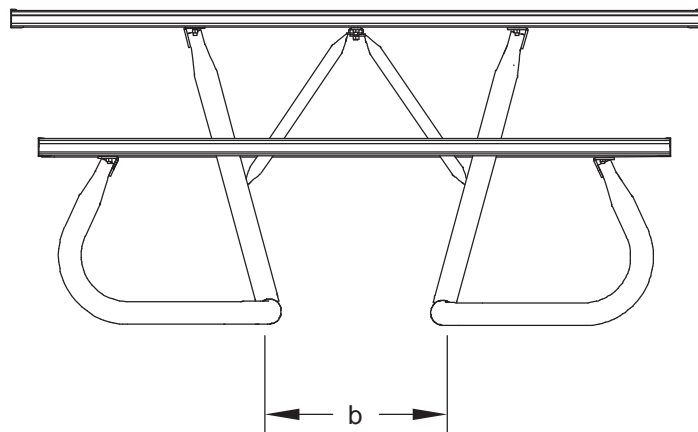

ALL DIMENSIONS IN INCHES

RJThomas Mfg. Co., Inc.
P.O. Box 946 • Cherokee, IA 51012-0946

DRAWN BY
WWM

TITLE **WXTH SERIES 6 AND 8 FOOT RAISED TOP UNIVERSAL ACCESS TABLE
WITH ALUMINUM TOP AND SEAT PLANKS**

DATE 11-20-08

DWG. NO. **AI-1646**