



*Model XT/G-6AL 6 Ft. Extra Heavy Duty Portable Rectangular Table
with Hot Dip Galvanized Frame and Aluminum Top and Seats*

- **Constructed specifically for heavy use areas**
- **Nontip, nontrip, walk-through design**
- **All welded end frames are fabricated from 2-3/8" diameter steel pipe**
- **Die-formed center channel and diagonal braces align and strengthen entire table**
- **Frames are hot dip galvanized after fabrication for superior corrosion resistance**
- **Seats and Top are Aluminum with a clear anodized maintenance free finish**
- **Limited lifetime warranty on frames**

AVAILABLE OPTIONS

6' or 8' length

Powder Coat Finish in choice of colors for steel frame components

Powder Coat Finish in choice of colors for aluminum top and seat components

SPECIFICATIONS:

- **XT Series** end frames are one-piece welded construction, fabricated from 2.375" O.D. (2-3/8" O.D.) steel pipe to meet 2" nominal steel pipe size specifications with 2" x 2" x 1/8" die formed steel angle for attaching the seats and tops.
- Table frame design incorporates nontip, nontrip, walk-through design features. Bends are tightly formed to prevent tipping when weight is on one side.
- **Model XT/G-6** has a nom. 6 ft. length.
- **Model XT/G-8** has a nom. 8 ft. length.
- Nominal table height is 30". Nominal seat height is 18".
- Frames are supported by diagonal braces of 1-5/16" O.D. x 14 ga. wall steel pipe that connect to a die-formed steel channel designed to align and provide attachment to the table top.
- **Standard:** All steel frame components are hot-dip galvanized after fabrication to ASTM-A123 to maintain an average zinc coating of 2.0 oz. per sq. ft. of surface area (indicated by "/G" in model no., e.g. XT/G-6AL).
- Aluminum is extruded 6063-T6 aluminum alloy in planks with dimensions equivalent to that of 2" x 10" nominal sized lumber. The plank design is 1-3/4" x 9-5/8" with four structural reinforcement ribs for greater rigidity. Aluminum planks are provided with a clear anodized finish as per anodizing specification 204 R1. Aluminum clips to fasten planks to frames are included.
- Channel end caps are extruded 6063-T6 aluminum alloy provided with a clear anodized finish as per anodizing specification 204 R1. End caps are press fitted over ends of aluminum planks and mechanically fastened in place at the factory.
- Table top is assembled into single unit (at the factory) with one-piece end caps across each end.
- All fasteners are provided for assembly.
- **Optional:** All steel frame components are powder coat finish. See Specification Bulletin #SPC-CO-001.
- **Optional:** Aluminum top and seat planks and end caps are powder coat finish. See Specification Bulletin #SPC-CO-001.

RJ Thomas Mfg. Co., Inc.

PO Box 946 • Cherokee, IA 51012-0946 • PH: 712-225-5115 • 800-762-5002 • FAX: 712-225-5796
E-mail: pilotrock@rjthomas.com • Web Site: <http://www.pilotrock.com>

© 2017 RJ Thomas Mfg. Co., Inc. PILOT ROCK® Park Products is a registered trademark of RJ Thomas Mfg. Co., Inc.

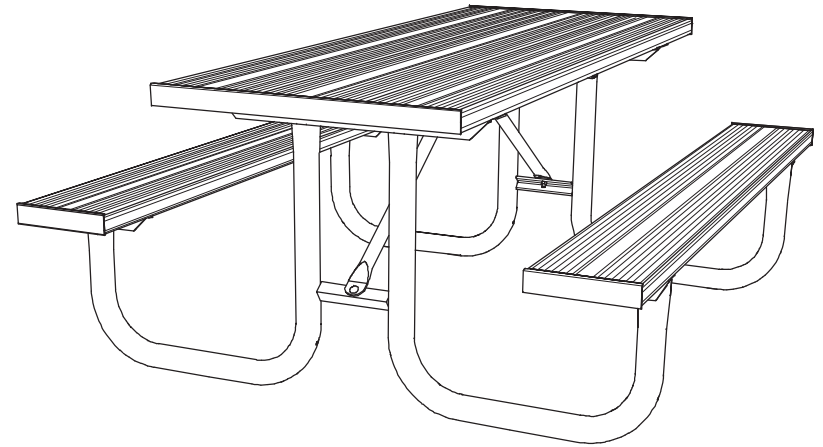
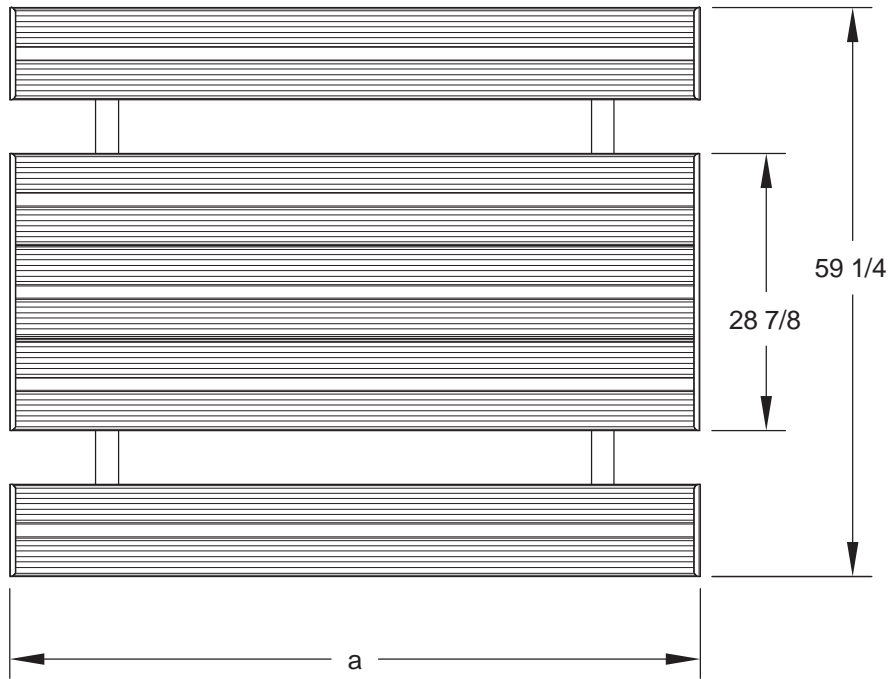

MODEL NUMBER	DIMENSION	
	a	b
XT/G-6	72	51 3/4
XT/G-8	96	70

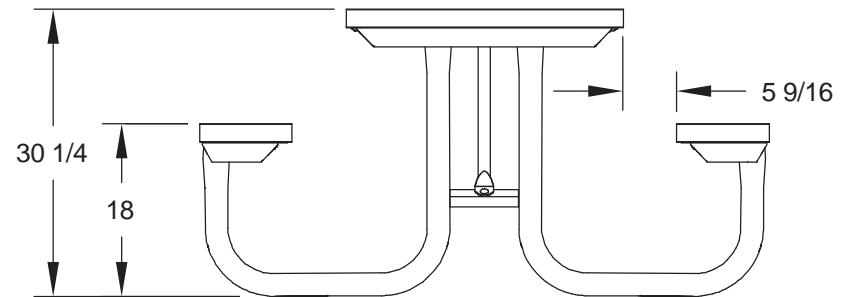
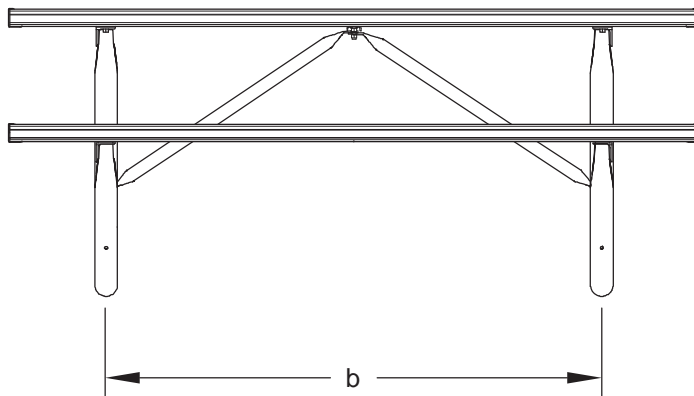

ALL DIMENSIONS IN INCHES

RJThomas Mfg. Co., Inc.
P.O. Box 946 • Cherokee, IA 51012-0946

DRAWN BY
WWM

TITLE XT SERIES 6 AND 8 FOOT PORTABLE RECTANGULAR TABLES WITH
ALUMINUM PLANK TOPS AND SEATS

DATE 11-21-08

DWG. NO. AI-1474