



*Model XT/CB-6VA/E 6 Ft. Wheelchair Accessible Table  
with black powder coat frames and gray V-Type  
thermo-plastic coated expanded steel top and seats*

- **Extended top for wheelchair accessibility at one end**
- **Constructed specifically for heavy use areas**
- **Top and seats designed for more abusive environments such as high elevations where snow loads can destroy average tables**
- **Nontip, nontrip, walk-through design**
- **All welded end frames are fabricated from 2-3/8" diameter steel pipe**
- **Die-formed channels and diagonal braces support table extensions**
- **Frames are hot-dip galvanized after fabrication for superior corrosion resistance**
- **Thermo-plastic Coating heat fused to Expanded Steel Top and Seats for durability**
- **Thermo-plastic Coating formulated with U.V. stabilizers for ultraviolet protection**
- **Limited lifetime warranty on frames**

#### **AVAILABLE OPTIONS**

- **Powder Coat Finish in choice of colors for steel frame components**
- **Choice of colors of Thermo-plastic Coating**

#### **SPECIFICATIONS:**

- **XT Series** end frames are one-piece welded construction, fabricated from 2.375" (2-3/8" O.D.) steel pipe to meet 2" nominal steel pipe size specifications with 2" x 2" x 1/8" die formed steel angle for attaching the seats and tops. "Outriggers" are attached to the frame on the extended end of the table for added stability.
- Table top extends 2 ft. beyond seats (indicated by "E" in model no., e.g. XT/G-6VW/E) to provide the ADA recommended wheelchair clearances of: 30" wide, 27" under table (ground to bottom of table top), and 24" total knee and toe clearance (19" + 5").
- A diagonal brace of 1-5/16" O.D. steel pipe and a die-formed steel channel is provided to support extended portions of table top.
- **Model XT/G-6VW/E** has a nom. 8 ft. long top and 6 ft. long seats. Includes frame stabilizing outriggers.
- Frames are supported by diagonal braces of 1-5/16" O.D. steel pipe that connect to the table top.
- Table height provides a nominal 28" of clearance from ground level to the underside of the table top. Nominal seat height is 18-1/2".
- **Standard:** All steel frame components are hot-dip galvanized after fabrication to ASTM-A123 to maintain an average zinc coating of 2.0 oz. per sq. ft. of surface area (indicated by "/G" in model no., e.g. XT/G-6VW/E).
- All fasteners are provided for assembly.
- **V-Type** table top and seats are each a one-piece welded construction, fabricated from a 3/4-#9 expanded steel surface with 10 ga. x 2-1/2" roll-formed vertical edges on all sides and reinforced by a 10 ga. die-formed angle substructure. Substructure includes all mounting holes for easy assembly of table.
- **Standard:** All steel surfaces of the top and seats are covered with a thermo-plastic coating in a Brown color (indicated by "VW" in model no., e.g. XT/G-6VW/E). The UV-stabilized thermo-plastic coating is applied in a multi step process of material preparation and finish application designed to permanently heat fuse and bond the finish to the steel. The thermo-plastic polyethylene finish is impact resistant, does not support mold or mildew, and the textured matte surface is less susceptible to marring and scuffing.
- **Optional:** Color choices of powder coated steel frame components. See Specification Bulletin #SPC-CO-001.
- **Optional:** Color choices of Thermo-plastic coated steel components. For optional colors choices see Specification Bulletin #SPC-CO-001.

**RJ Thomas Mfg. Co., Inc.**

PO Box 946 • Cherokee, IA 51012-0946 • PH: 712-225-5115 • 800-762-5002 • FAX: 712-225-5796  
E-mail: pilotrock@rjthomas.com • Web Site: <http://www.pilotrock.com>

© 2017 RJ Thomas Mfg. Co., Inc. PILOT ROCK® Park Products is a registered trademark of RJ Thomas Mfg. Co., Inc.

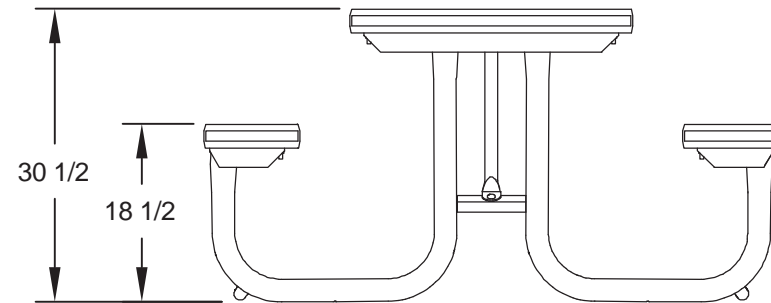
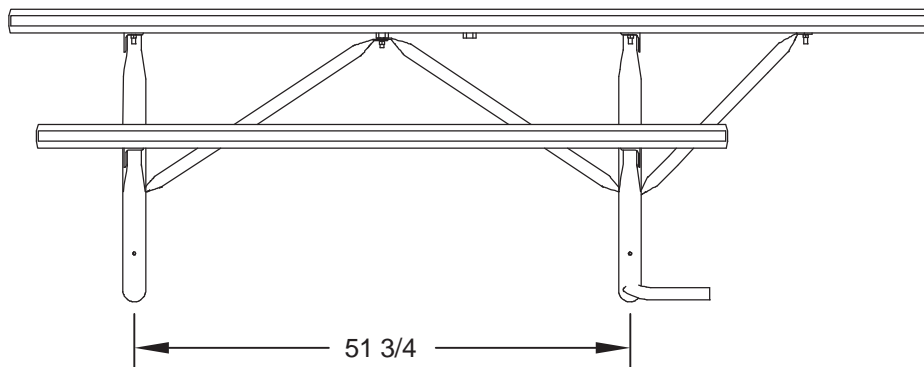
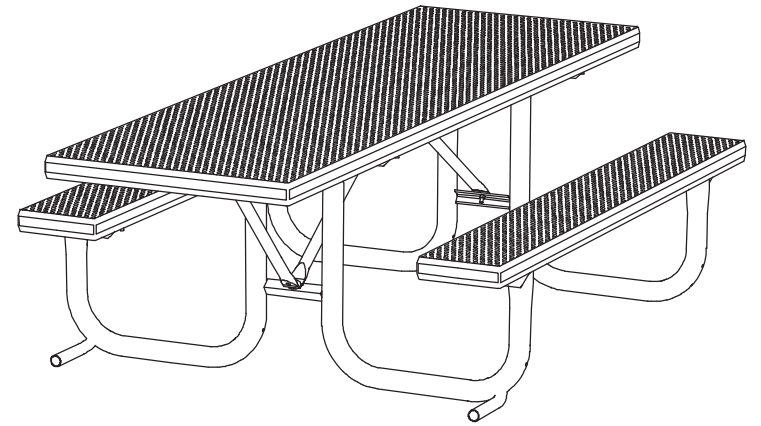
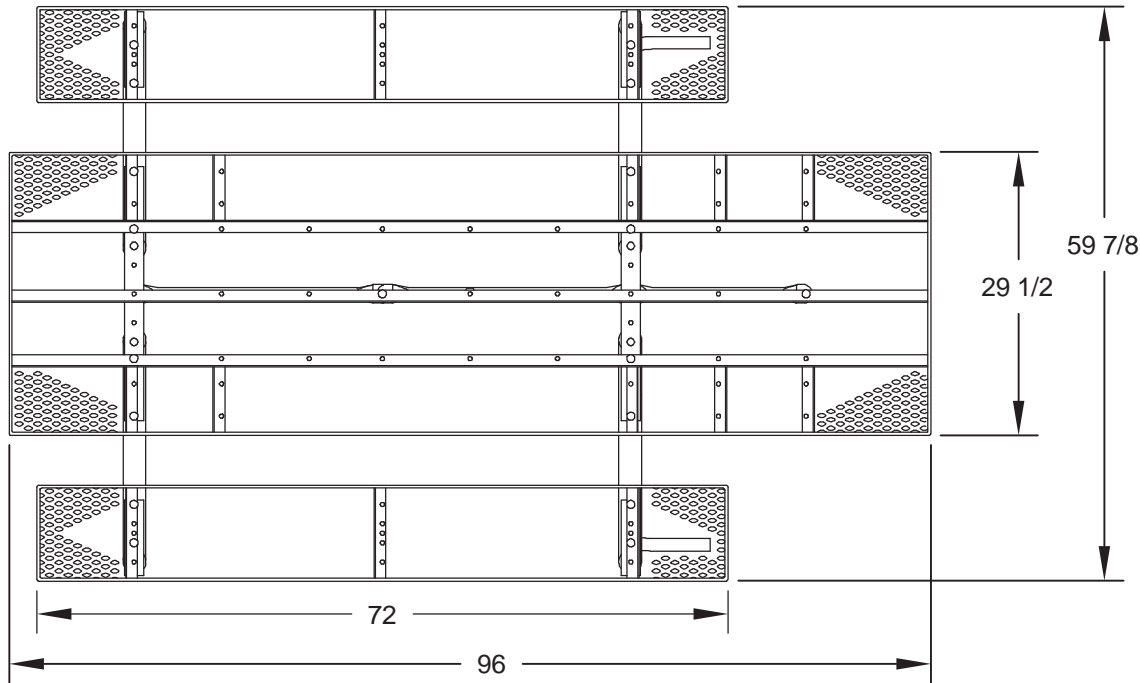

ALL DIMENSIONS IN INCHES

**RJThomas Mfg. Co., Inc.**  
P.O. Box 946 • Cherokee, IA 51012-0946

DRAWN BY  
**WWM**

TITLE **XT SERIES 6 FOOT WHEELCHAIR ACCESSIBLE PORTABLE RECTANGULAR TABLE  
EXTENDED 2 FOOT ON ONE END WITH V-TYPE THERMO-PLASTIC COATED  
EXPANDED STEEL TOP AND SEATS**

DATE **3-05-10**

DWG. NO. **AI-1689**