



*Model XTH/G-6UP/E, 6 ft., Extra Heavy Duty Wheelchair Accessible Portable Table, Extended 2 ft. One End, with hot dip galvanized Frames and Untreated Pine Top and Seats*

- **ADA compliant wheelchair accessibility at one end**
- **Constructed specifically for heavy use areas**
- **Nontip, nontrip walk-through design**
- **All welded end frames are fabricated from 2-3/8" diameter steel pipe**
- **Die-formed center channel and diagonal braces align and strengthen entire table**
- **Frames are hot dip galvanized after fabrication for superior corrosion resistance**
- **Precision drilled, Untreated #1 Southern Yellow Pine Top and seat Planks**
- **Limited lifetime warranty on frames**

#### **SPECIFICATIONS:**

- **XTH Series** end frames are one-piece welded construction, fabricated from 2.375" O.D. (2-3/8" O.D.) steel pipe to meet 2" nominal steel pipe size specifications with 2" x 2" x 1/8" die formed steel angle for attaching the seats and tops. "Outriggers" are attached to the frame on the extended end of the table for added stability.
- Table frame design incorporates nontip, nontrip, walk-through design features. Bends are tightly formed to prevent tipping when weight is on one side.
- Table provides one wheelchair space at one end of table by extending the top 2 ft. creating a ADA recommended space of 30" wide, 19" deep, and 27" from ground to bottom of table top for knee space, and minimum 9" above ground extending a total of 24" deep for toe space. Indicated by "E" at end of model no., e.g. XTH/G-6UP/E.
- A diagonal brace of 1-5/16" O.D. steel pipe and a die-formed steel channel is provided to support extended portions of table top and maintain planks against warping.
- **Model XTH/G-6UP/E** has a nom. 8 ft. long top and 6 ft. long seats. Includes frame stabilizing outriggers.
- **Model XTH/G-8UP/E** has a nom. 10 ft. long top and 8 ft. long seats.
- Frame design provides a nominal 30" of clearance from ground level to the underside of the table top and nominal seat top height of 19".
- Frames are supported by diagonal braces of 1-5/16" O.D. steel pipe that connect to a die-formed steel channel designed to align and provide attachment to the table top.
- All fasteners are provided for assembly.
- **Standard:** All steel frame components are hot-dip galvanized after fabrication to ASTM-A123 to maintain an average zinc coating of 2.0 oz. per sq. ft. of surface area (indicated by "/G" in model no., e.g. XTH/G-6AL/E).
- **Standard:** Lumber is Untreated #1 grade Southern Yellow Pine (indicated by "UP" in model no., e.g. XTH/G-6UP/E) 2" x 10" nominal sized planks, kiln dried to reduce moisture content. All lumber is precision drilled to facilitate assembly and has all exposed edges removed to a 3/8" radius.
- **Optional:** All steel frame components have powder coat finish. See Specification Bulletin #SPC-CO-001.
- **Optional:** Treated #1 Southern Yellow Pine is readily available and shall be pressure treated (KDAT) to preserve wood against decay. To specify, change "UP" in model no. to "TP", e.g. XTH/G-6TP/E. (Cedar, Fir and Redwood are available when in stock -please inquire.)

#### **AVAILABLE OPTIONS**

- **6' or 8' lengths**
- **Powder Coat Finish in choice of colors for steel frame components**
- **Pressure treated #1 Southern Yellow Pine lumber (Cedar, Fir, or Redwood lumber when in stock)**

**RJ Thomas Mfg. Co., Inc.**

PO Box 946 • Cherokee, IA 51012-0946 • PH: 712-225-5115 • 800-762-5002 • FAX: 712-225-5796  
E-mail: pilotrock@rjthomas.com • Web Site: <http://www.pilotrock.com>

© 2018 RJ Thomas Mfg. Co., Inc. PILOT ROCK® Park Products is a registered trademark of RJ Thomas Mfg. Co., Inc.

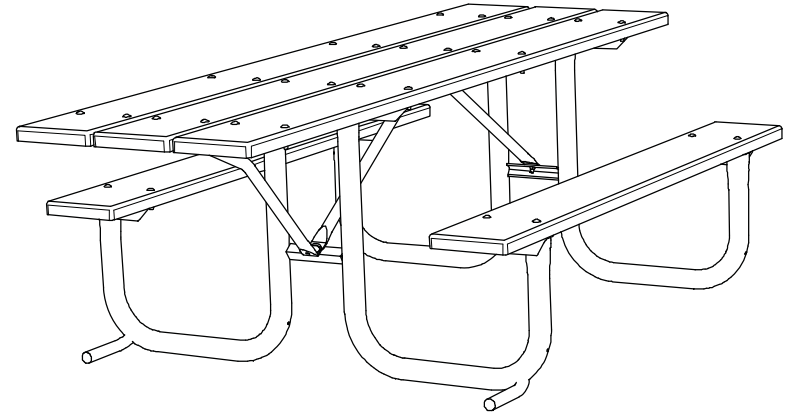
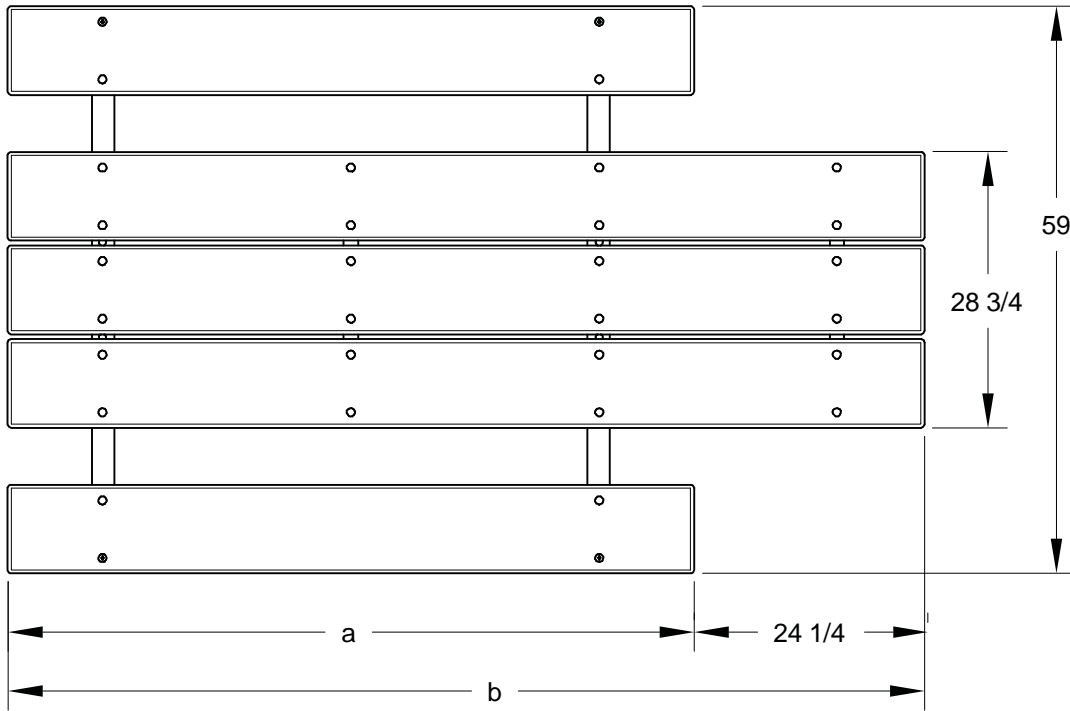

MODEL NUMBER	DIMENSION			STABILIZING OUTRIGGERS
	a	b	c	
XTH-6/E	71 1/2	95 1/2	51-3/4	INCLUDED
XTH-8/E	95 1/2	119 1/2	70	NOT REQUIRED

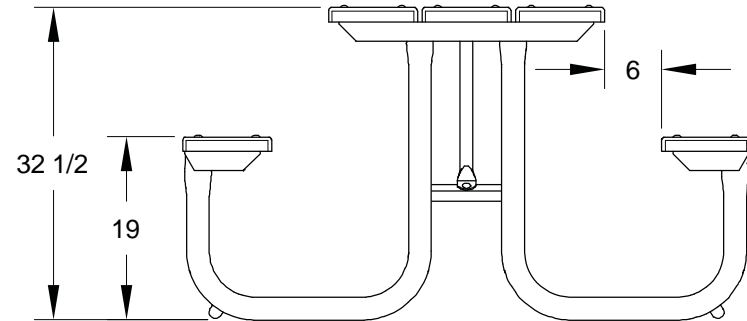
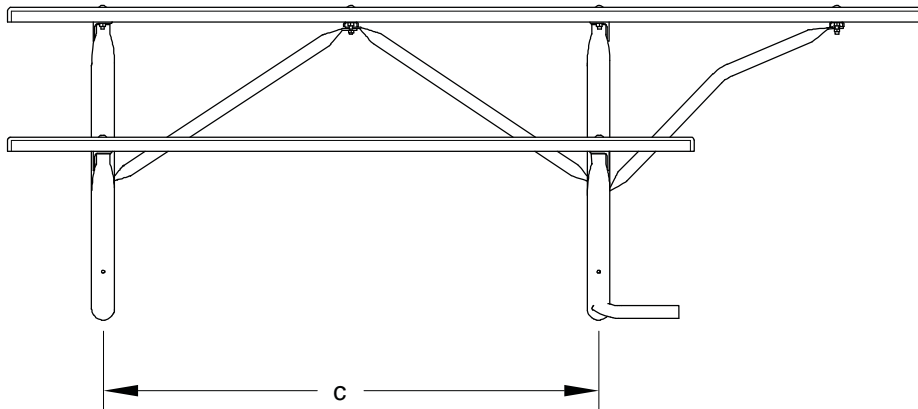

ALL DIMENSIONS IN INCHES

**RJThomas Mfg. Co., Inc.**  
P.O. Box 946 • Cherokee, IA 51012-0946

DRAWN BY  
**WWM**

TITLE XTH SERIES 6 AND 8 FOOT WHEELCHAIR ACCESSIBLE RECTANGULAR TABLES  
EXTENDED 2 FOOT ONE END WITH LUMBER TOP AND SEAT PLANKS

DATE 2-14-11

DWG. NO. AI-1728