



Model AFT/C-6PC 6 ft. All Recycled Plastic A-Frame Rectangular Table with cedar colored recycled plastic legs and cedar colored recycled plastic top and seat planks

- **Traditional A-Frame design**
- **Sturdy 4" x 6" Recycled Plastic legs**
- **100% Recycled Plastic construction with solid color and U.V. stabilizer for ultraviolet protection**
- **Quality construction throughout**

SPECIFICATIONS:

- **AFT Series** end frames are constructed from two 4" x 6" nominal sized timbers forming the legs of the "A" with ends cut at angles to provide firm contact with ground surface. Legs are connected at top by a 2" x 4" recycled plastic timber which also provides attachment of table top planks. A 2" x 6" recycled plastic timber connects legs at seat height and extends beyond legs to provide mounting and support for seat planks.
- Table is supported by diagonal braces of 2" x 4" recycled plastic that connect to a 2" X 4" center top support designed to align and provide attachment to the table top. Six foot model has two braces between legs, eight foot model has two braces between legs and one on each end to support the top.
- **Model AFT/W-6PC** shall have a nominal length of 72".
- **Model AFT/W-8PC** shall have a nominal length of 96".
- Nominal table height is 30-1/4", seat height is 17-3/4".
- All fasteners are provided for assembly.
- **Standard:** Tops and seats are made of 100% Recycled Plastic molded into 2" x 10" nominal sized planks with solid Cedar colored (indicated by "PC" in model no., e.g. AFT/W-6PC) formed throughout and a U.V. stabilizer added for ultra-violet protection.
- **Standard:** Leg timbers are made of 100% Recycled Plastic molded into 4" x 6" nominal sized timber with solid Brown color (indicated by "/W" following AFT in model no., e.g. AFT/W-6PC) formed throughout and a U.V. stabilizer added for ultra-violet protection.
- Seat planks are supported by 2" x 6" recycled plastic timbers on edge under the seat planks.
- **Optional:** Recycled Plastic is available in a choice of colors. Colors of AFT series table legs and top/seat planks can be mixed or matched. For optional colors choices see Specification Bulletin #SPC-CO-001.
- **Wheelchair Access:** Table top on eight foot model extends beyond frame on each end to provide the ADA recommended wheelchair clearances of: 30" wide, 27" under table (ground to bottom of table top), and 24" total knee and toe clearance (19" + 5") at both ends.

AVAILABLE OPTIONS

- **6' and 8' lengths**
- **Choice of colors of Recycled Plastic**

RJ Thomas Mfg. Co., Inc.

PO Box 946 • Cherokee, IA 51012-0946 • PH: 712-225-5115 • 800-762-5002 • FAX: 712-225-5796
E-mail: pilotrock@rjthomas.com • Web Site: <http://www.pilotrock.com>

© 2008 RJ Thomas Mfg. Co., Inc. PILOT ROCK® Park Products is a registered trademark of RJ Thomas Mfg. Co., Inc.

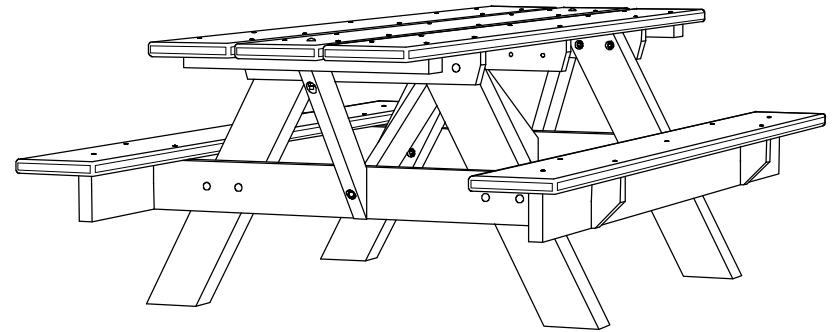
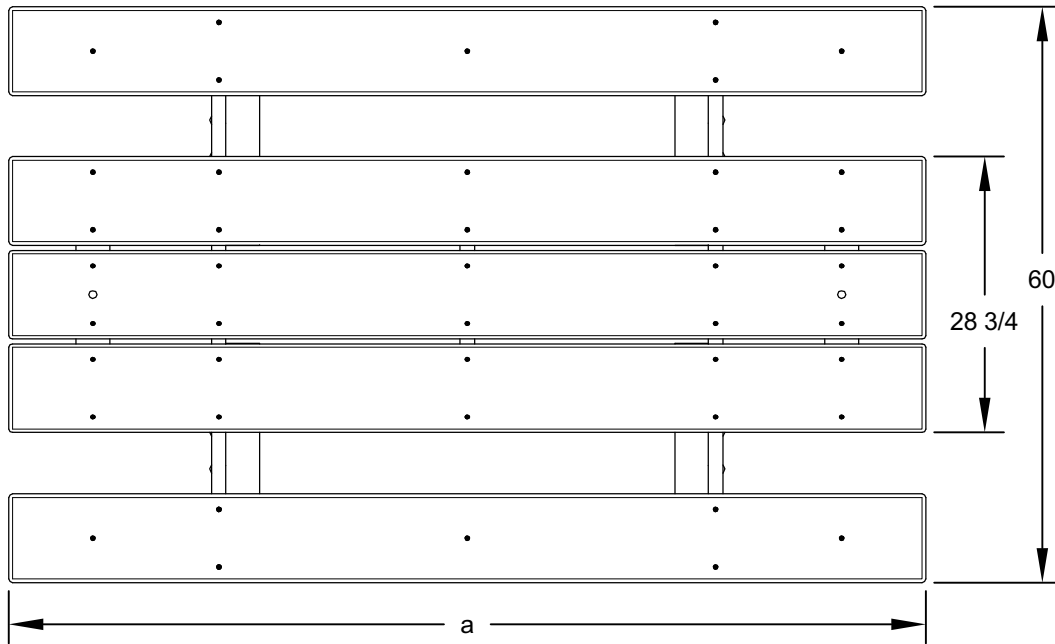

	DIMENSION
MODEL	a
AFT-6	71 1/2
AFT-8	95 1/2

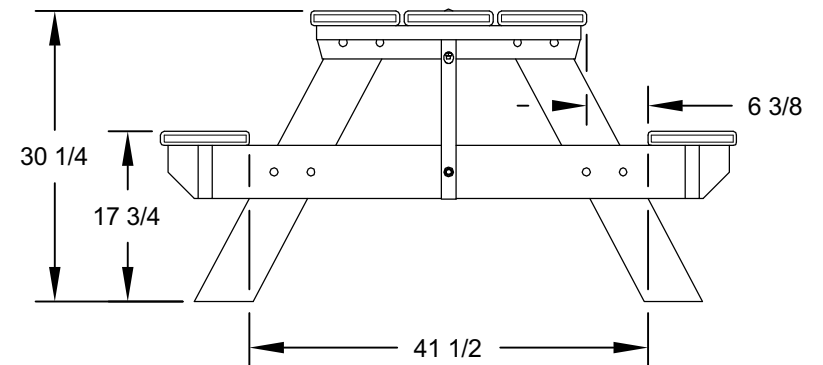
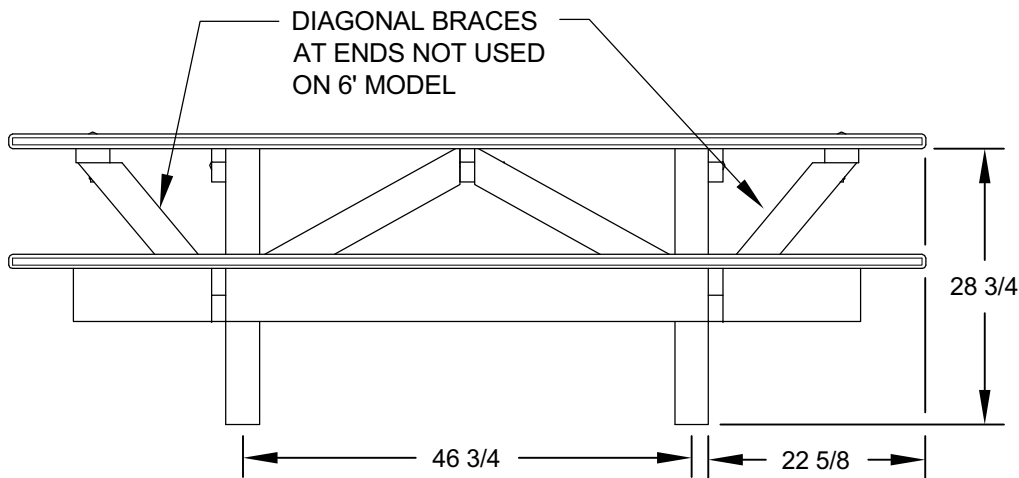

ALL DIMENSIONS IN INCHES

RJThomas Mfg. Co., Inc.
P.O. Box 946 • Cherokee, IA 51012-0946

DRAWN BY
WWM

TITLE AFT SERIES 6 AND 8 FOOT PORTABLE ALL RECYCLED PLASTIC A-FRAME TABLE

DATE 11-08-10

DWG. NO. **AI-1970**