



**Model ART/B-6R/E1** 6 ft. Accessible Recycled Plastic Rectangular Table with black end frames and red top and seat planks

- **Molded 100% Recycled Plastic Arched Legs**
- **Step-over seat design**
- **100% Recycled Plastic Seat and Top Planks**
- **Solid color throughout plastic and U.V. stabilizer for ultraviolet protection**
- **Quality construction throughout**
- **ADA compliant wheelchair access at both ends**

#### **SPECIFICATIONS:**

- **ART Series** table has an arched leg, step-over seat design with three frames molded of 100% recycled plastic in 3" thick profiles. Table provides a nom. seat height of 17-1/2" and nom. table top height of 30-1/2".
- Table top extends 1 ft. beyond seats on each end (indicated by "/E1" at end of model no., e.g. ART/W-6C/E1) to provide the ADA recommended wheelchair clearances of: 30" wide, 27" under table (ground to bottom of table top), and 24" total knee and toe clearance (19" + 5") at both ends. Blue recycled plastic end caps on the table top identifies the table as accessible and align and support the planks against warping.
- **Model ART/W-6/E1** shall have a nominal seat length of 72" and a nominal table top length of 97".
- All stainless steel screws are provided for assembly.
- **Standard:** Leg frames are made of 3" thick 100% Recycled Plastic with solid Brown color (indicated by "/W" following ART in model no., e.g. ART/W-6C/E1) formed throughout and a U.V. stabilizer added for ultra-violet protection.
- **Standard:** Tops and seats are made of 100% Recycled Plastic molded into 2" x 6" nominal sized planks with solid Cedar colored (indicated by "C" in model no., e.g. ART/W-6C/E1) formed throughout and a U.V. stabilizer added for ultra-violet protection.
- **Optional:** Recycled Plastic frame legs are available in black (specify by changing "/W" following ART in model no. to "/B", e.g. ART/B-6C/E1).
- **Optional:** Color choices of Recycled Plastic top and seat planks. For optional colors choices see Specification Bulletin #SPC-CO-001.

#### **AVAILABLE OPTIONS**

- **Choice of colors of Recycled Plastic Top and Seat Planks**
- **Choice of Black or Brown Recycled Plastic Frames**
- **Custom Lettering and Plaques available (call for details)**

**RJ Thomas Mfg. Co., Inc.**

PO Box 946 • Cherokee, IA 51012-0946 • PH: 712-225-5115 • 800-762-5002 • FAX: 712-225-5796  
E-mail: pilotrock@rjthomas.com • Web Site: <http://www.pilotrock.com>

© 2012 RJ Thomas Mfg. Co., Inc. PILOT ROCK® Park Products is a registered trademark of RJ Thomas Mfg. Co., Inc.

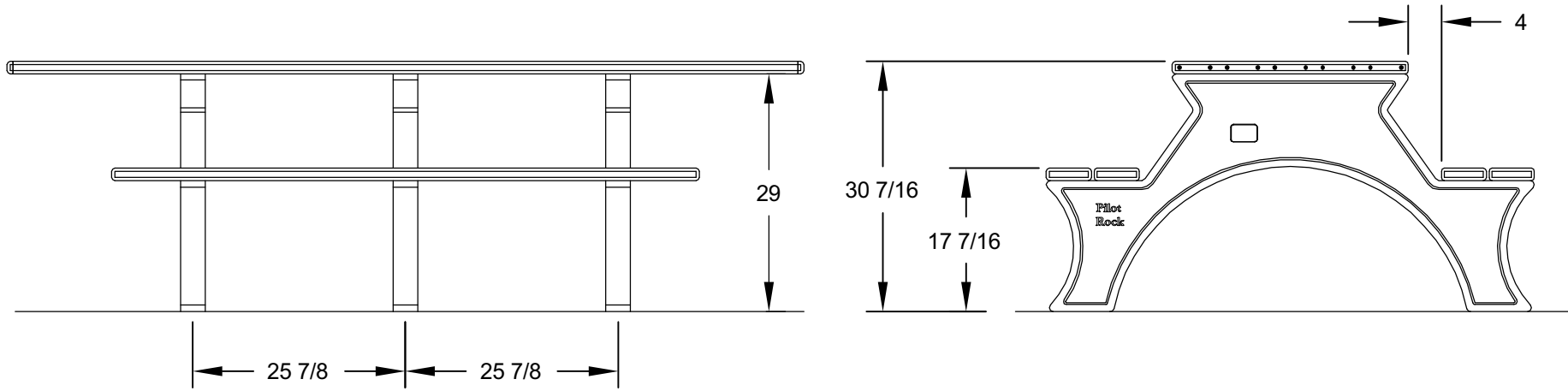
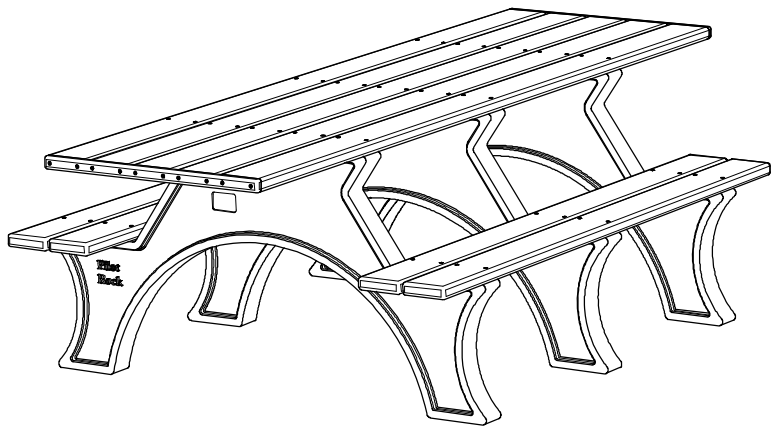
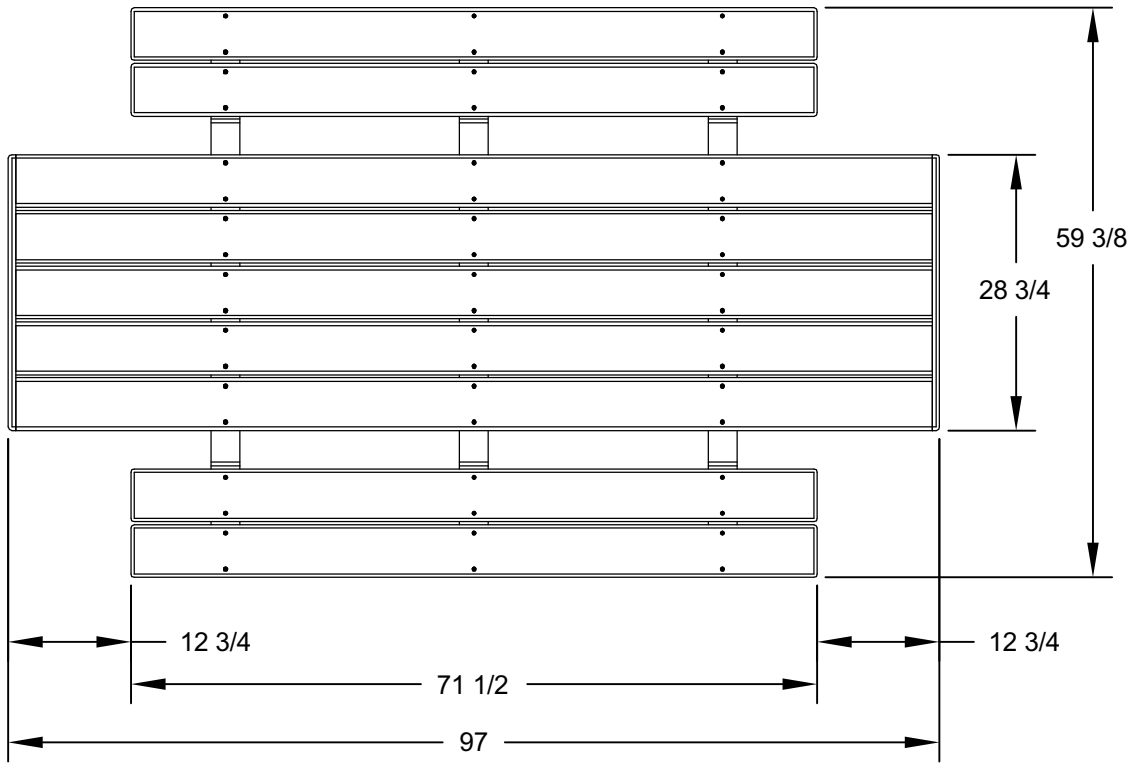

ALL DIMENSIONS IN INCHES

**RJThomas Mfg. Co., Inc.**  
 P.O. Box 946 • Cherokee, IA 51012-0946

DRAWN BY  
**MGB**

TITLE ART SERIES 6 FOOT WHEELCHAIR ACCESSIBLE, EXTENDED TOP RECYCLED  
 PLASTIC RECTANGULAR TABLE; TABLE TOP EXTENDED 1 FOOT EACH END

DATE 2-17-12

DWG. NO. AI-2016