

AT Series 6 foot Accessible A-Frame Rectangular Table with Recycled Plastic Timbers and Planks

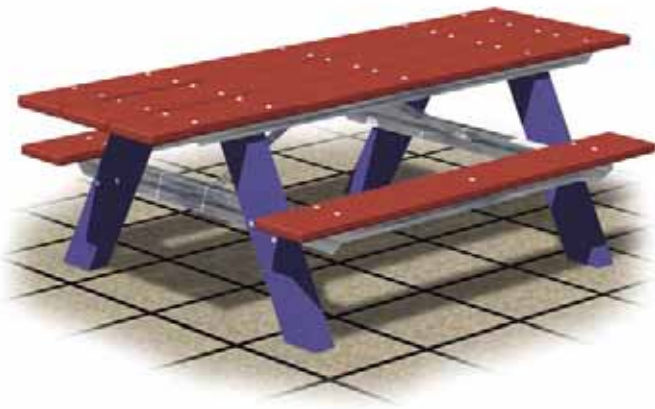

*Model AT/U-6PR/E1 6 ft. Accessible A-Frame Rectangular Table
with Blue Recycled Plastic Legs and Red Recycled Plastic
Top and Seat Planks*

- **Traditional A-Frame design**
- **Extended one foot on each end for wheelchair accessibility at both ends**
- **Sturdy 4" x 6" Recycled Plastic Legs**
- **100% Recycled Plastic Seat and Top Planks with solid color and U.V. stabilizer for ultraviolet protection**
- **Pregalvanized steel channel cross-member**
- **Pregalvanized steel channel reinforcements under seats and table top**
- **Quality construction throughout**

AVAILABLE OPTIONS

Choice of colors of Recycled Plastic

SPECIFICATIONS:

- **AT Series** end frames are constructed from two 4" x 6" nominal sized timbers forming the legs of the "A" with ends cut at angles to provide firm contact with ground surface. Legs are connected at top by a 10 ga. x 2" x 2" formed pregalvanized steel angle which also provides attachment of table top planks. A formed pregalvanized 10 ga. x 1-3/4" x 4" steel channel connects legs at seat height and extends beyond legs to provide mounting and support for seat planks.
- Table is supported by diagonal braces of 1-5/16" O.D. pregalvanized steel pipe that connect to a die-formed steel channel designed to align and provide attachment to the table top.
- **Model AT/W-6PC/E1** has a nominal seat length of 72" and a nominal top length of 96".
- Table top extends 1 ft. beyond seats on each end to provide the ADA recommended wheelchair clearances of: 30" wide, 27" under table (ground to bottom of table top), and 24" total knee and toe clearance (19" + 5") at both ends.
- All galvanized fasteners are provided for assembly.
- **Standard:** Tops and seats are made of 100% Recycled Plastic molded into 2" x 10" nominal sized planks with solid Cedar colored (indicated by "PC" in model no., e.g. AT/W-6PC/E1) formed throughout and a U.V. stabilizer added for ultra-violet protection.
- **Standard:** Leg timbers are made of 100% Recycled Plastic molded into 4" x 6" nominal sized timber with solid Brown color (indicated by "/W" following AT in model no., e.g. AT/W-6PC/E1) formed throughout and a U.V. stabilizer added for ultra-violet protection.
- Recycled Plastic table top and seat planks are supported by pregalvanized steel subframe channels.
- **Optional:** Recycled Plastic is available in a choice of colors. Colors of AT series table legs and top/seat planks can be mixed or matched. For optional colors choices see Specification Bulletin #SPC-CO-001.
- **Optional:** Color choices of powder coated steel frame components. To indicate Brown powder coat finish, add "/CW" after "/W" in model no.. e.g. AT/W/CW-6PC/E1. For optional colors choices see Specification Bulletin #SPC-CO-001.

RJThomas Mfg. Co., Inc.

PO Box 946 • Cherokee, IA 51012-0946 • PH: 712-225-5115 • 800-762-5002 • FAX: 712-225-5796
E-mail: pilotrock@rjthomas.com • Web Site: <http://www.pilotrock.com>

© 2008 RJThomas Mfg. Co., Inc. PILOT ROCK® Park Products is a registered trademark of RJThomas Mfg. Co., Inc.

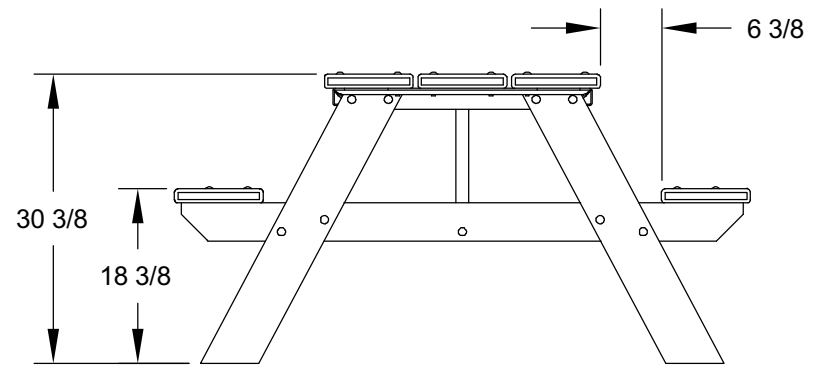
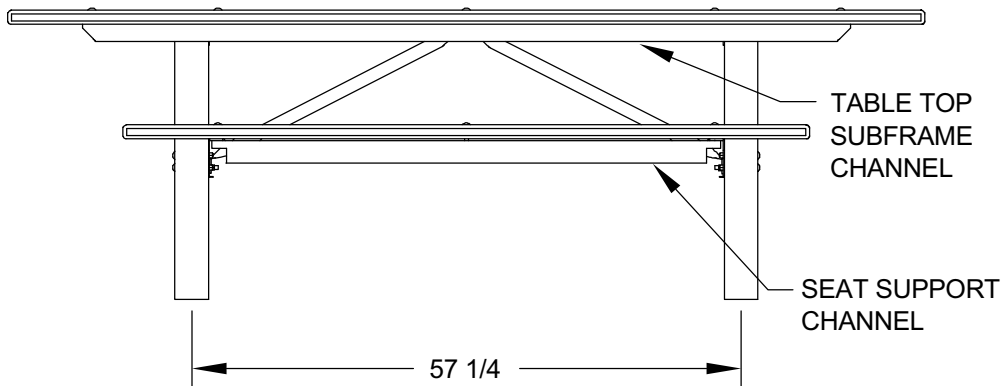
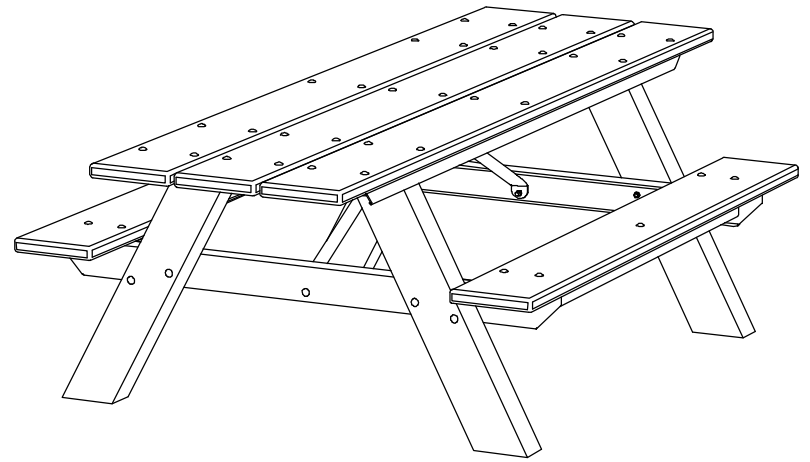
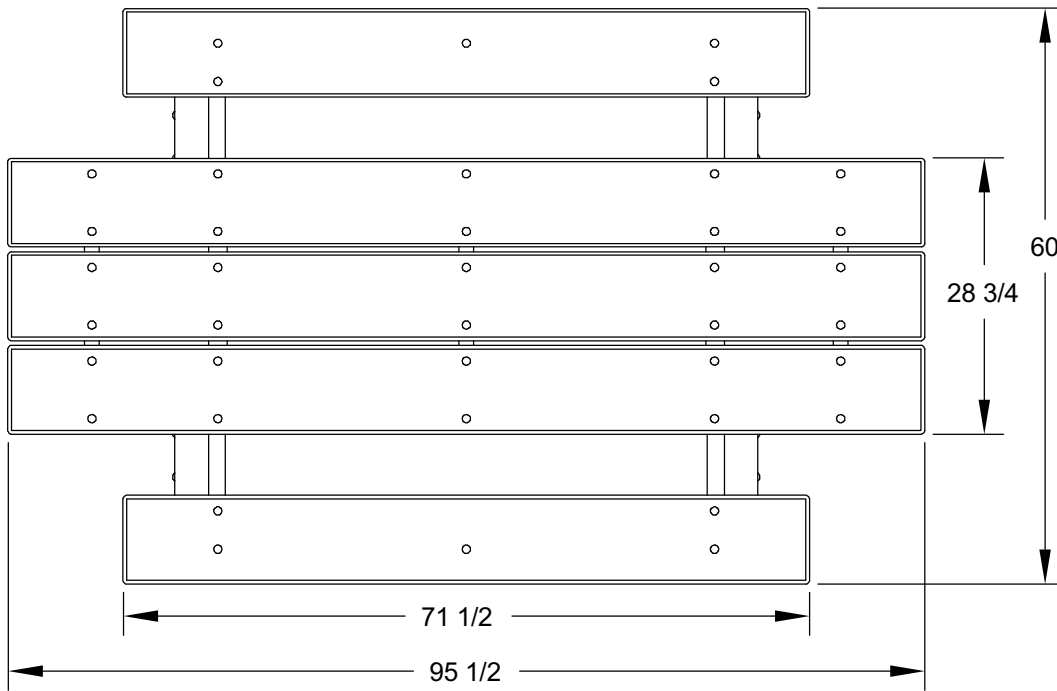

ALL DIMENSIONS IN INCHES

RJThomas Mfg. Co., Inc.
P.O. Box 946 • Cherokee, IA 51012-0946

DRAWN BY
WWM

TITLE AT SERIES 6 FOOT WHEELCHAIR ACCESSIBLE A-FRAME TABLE EXTENDED
1 FOOT ON BOTH ENDS WITH RECYCLED PLASTIC TIMBERS AND PLANKS

DATE 10-31-08

DWG. NO. AI-1715