

Model B111C 6 Foot Accessible Contoured Bench with Lumber Seat



Model B111C/G-6TP24 Accessible Embedded mount Contoured Bench, 6 foot long, with hot dip galvanized frames and 2" x 4" treated Southern Yellow Pine seat planks

- **Meets suggested ABA and ADA guidelines for accessible seating**
- **Grab bar across full length at top of the back aids transfer to and from bench**
- **Extra heavy design to be stronger and more stable with a simple, clean design.**
- **Sturdy, formed and welded steel frame construction**
- **Frames are Hot-Dip Galvanized after fabrication for superior corrosion resistance**
- **Precision drilled, Treated #1 Southern Yellow Pine Planks**
- **Quality construction throughout**

SPECIFICATIONS:

- **Model B111C** end frames are one-piece, welded construction with a back and seat bracket of 2-3/8" x 1-1/2" x 1/8" nominal sized, die-formed channel, and a 2.375" (2-3/8") O.D. post and foot to meet 2" nominal steel pipe size specifications. Frame leg is designed to be embedded 20-1/8" into a concrete footing.
- A grab bar die-formed from 1.66" OD x 10 ga. wall round steel tube with downward bends on the ends attached to the end frames at the top of the back provides support when transferring to and from bench seat.
- **Model B111C/G-6** is 6 ft. long (nom.) with three frames.
- **Standard:** Frames are hot-dip galvanized after fabrication to ASTM-A123 to maintain an average zinc coating of 2.0 oz. per sq. ft. of surface area (indicated by "/G" in model no., e.g. B111C/G-6TP24).
- **Standard:** Lumber shall be treated #1 grade Southern Yellow Pine (indicated by "TP" in model no., e.g. B111C/G-6TP24) 2" x 4" nominal sized planks, pressure treated and kiln dried after treatment (KDAT) to preserve wood against decay. All lumber shall be precision drilled to facilitate assembly and shall have all exposed edges removed to a 3/8" radius.
- All fasteners are provided for assembly.
- **Optional:** Color choices of powder coated steel frame components. For optional colors choices see Specification Bulletin #SPC-CO-001.

AVAILABLE OPTIONS

- **Powder Coat Finish in choice of colors for steel frame components**
- **Custom Lettering and Plaques available (call for details)**

- **Note:** Meets guidelines as presented in Federal Register, June 20, 2007, Part II Architectural and Transportation Barriers Compliance Board, 36 CFR Part 1195, ABA Guidelines for Outdoor Developed Areas; Proposed Rule: Part T213, T313 and T411. Also meets suggested design guidelines in ADA and ABA Accessibility Guidelines dated July 23, 2004, Chapter 9: Built-In Elements, Part 903 Benches

RJ Thomas Mfg. Co., Inc.

PO Box 946 • Cherokee, IA 51012-0946 • PH: 712-225-5115 • 800-762-5002 • FAX: 712-225-5796
E-mail: pilotrock@rjthomas.com • Web Site: <http://www.pilotrock.com>

© 2008 RJ Thomas Mfg. Co., Inc. PILOT ROCK® Park Products is a registered trademark of RJ Thomas Mfg. Co., Inc.

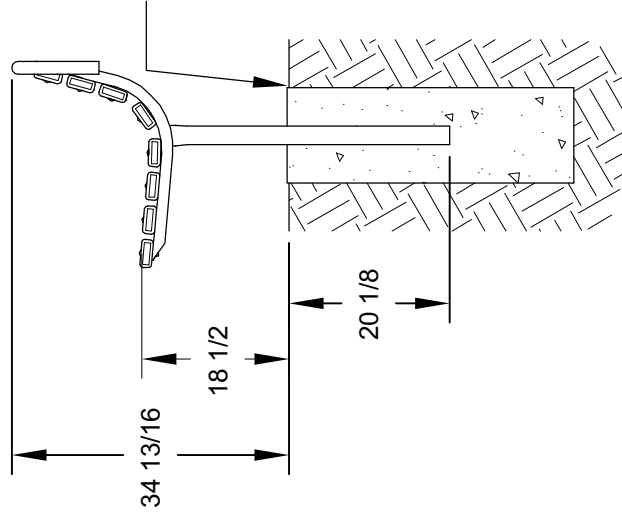
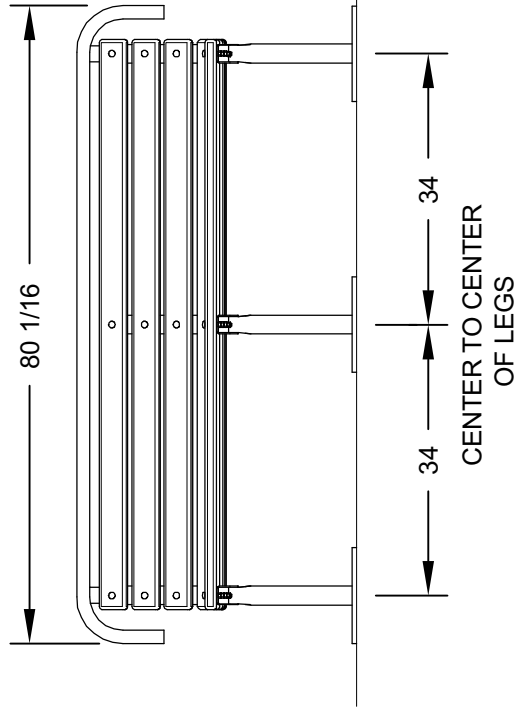
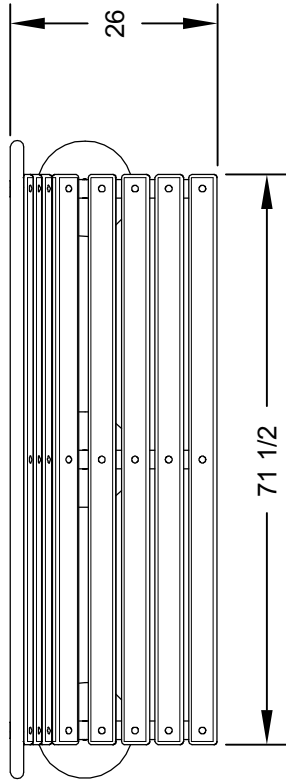
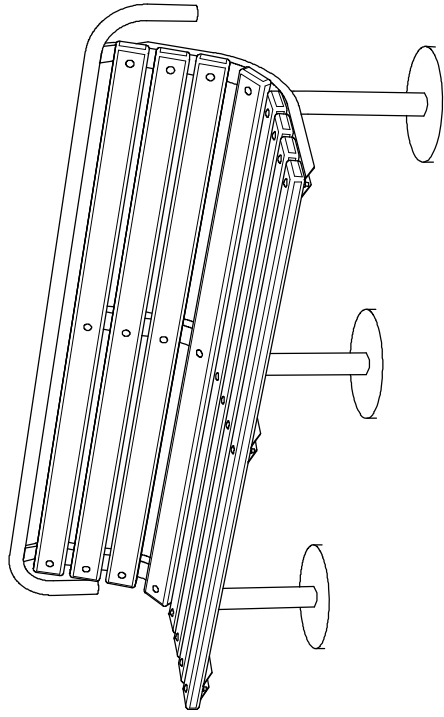

12" DIA. X 36"
DEEP MIN.
CONCRETE
FOOTING
NOTE: LOCAL
SOIL CONDITIONS
MAY REQUIRE A
LARGER FOOTING
(CHECK LOCAL
CODES)

ALL DIMENSIONS IN INCHES

RJThomas Mfg. Co., Inc.
P.O. Box 946 • Cherokee, IA 51012-0946

DRAWN BY
WWM

TITLE B111C SERIES 6 FOOT ACCESSIBLE EMBEDDED MOUNT BENCH WITH LUMBER
CONTOUR SEAT

DATE 1-18-11

DWG. NO.

AI-1982