



*Model B32/CB-6CO34 6 Ft. Surface Mount Bench
with Black Powder Coat Frames
and Construction Heart Redwood 3" x 4" Timbers.*

- **Comfortable contoured full back and seat design**
- **Wide, comfortable armrest loops integrated into end frames**
- **Sturdy, formed and welded steel frame construction**
- **Powder Coat or Hot Dip Galvanized frame finish**
- **Precision drilled Hardwood 3" x 4" Timbers**
- **Quality construction throughout**

SPECIFICATIONS:

- **Model B32 Series** end frames are one-piece welded construction with 3/8" x 2-1/2" A-36 flat steel bar legs and die-formed feet with 25/32" dia. anchor holes. Seat brackets are constructed of 3/8" x 2-1/2" A-36 flat steel bar, die-formed for shape and reinforcement, with holes to mount eight 3" x 4" timbers. The end frames include a welded-on circular armrest formed from 1/4" x 2-1/2" A-36 flat steel bar.
- **Model B32-4** is a nom. 4 ft. in length.
- **Model B32-6** is a nom. 6 ft. in length.
- Bench is designed to be permanently surface mounted using 25/32" dia. holes provided in each frame foot for use with concrete anchors (anchors not included).
- **Standard:** Frames are finished in Black powder coat (indicated by "/CB" in model no., e.g. B32/**CB**-4CO34).
- **Standard:** Lumber is Construction Heart Redwood 3" x 4" nominal sized timbers (indicated by "CO" in model no., e.g. B32/**CB**-4**CO**34). All timbers are precision drilled for assembly and have all exposed edges removed to a 3/8" radius with a bullnose profile timber used on top and front positions.
- All fasteners are provided for assembly.
- **Optional:** Color choices of powder coated steel frame components. For optional colors choices see Specification Bulletin #SPC-CO-001.
- **Optional:** Frames are hot-dip galvanized after fabrication to ASTM-A123 to maintain an average zinc coating of 2.0 oz. per sq. ft. of surface area. (To specify, change "/CB" in model no. to "/G", e.g. B32/**G**-4CO34).

AVAILABLE OPTIONS

- 4' or 6' models
- Powder Coat Finish in choice of colors or Hot Dip steel frame components
- Custom Lettering and Plaques available (call for details)

RJ Thomas Mfg. Co., Inc.

PO Box 946 • Cherokee, IA 51012-0946 • PH: 712-225-5115 • 800-762-5002 • FAX: 712-225-5796
E-mail: pilotrock@rjthomas.com • Web Site: <https://www.pilotrock.com>

© 2021 RJ Thomas Mfg. Co., Inc. PILOT ROCK® Park Products is a registered trademark of RJ Thomas Mfg. Co., Inc.

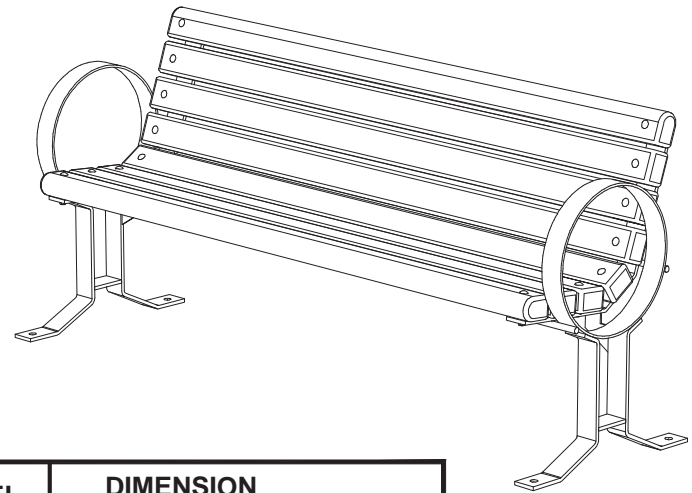
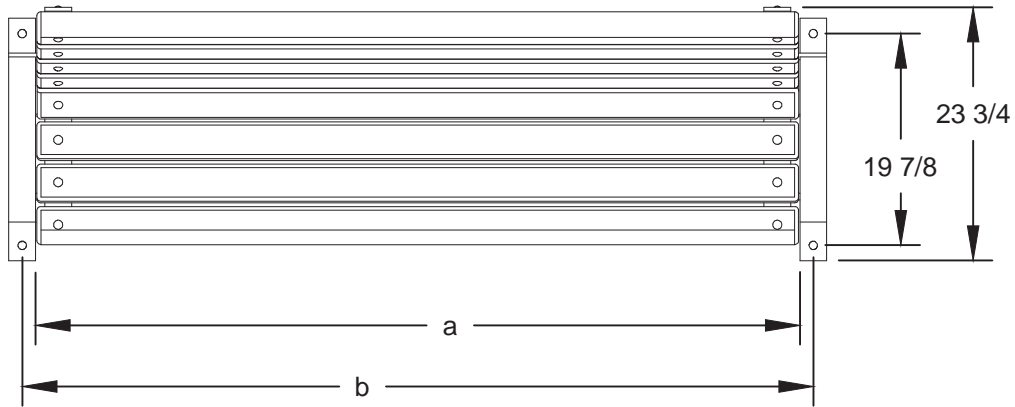

MODEL NUMBER	DIMENSION		
	a	b	c
B32-4	47 1/2	50 1/4	52 3/4
B32-6	71 1/2	74 1/4	76 3/4

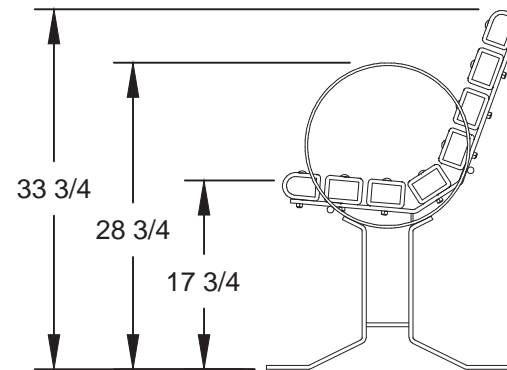
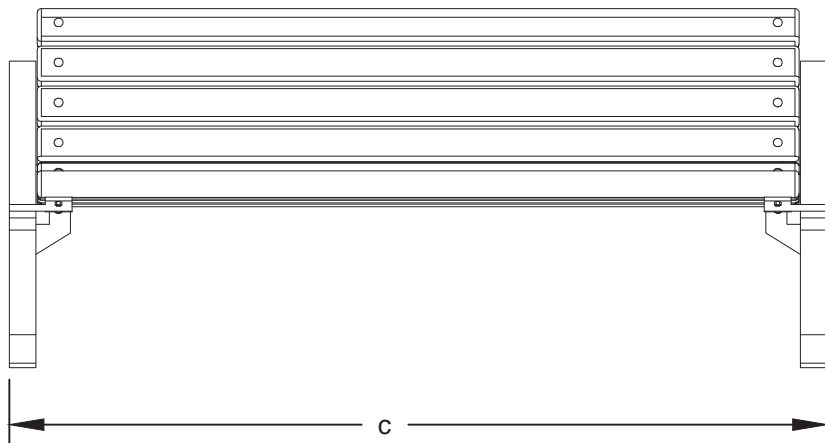

ALL DIMENSIONS IN INCHES

ALL DIMENSIONS IN INCHES

RJThomas Mfg. Co., Inc.
P.O. Box 946 • Cherokee, IA 51012-0946

DRAWN BY
WWM

TITLE **GREY CREEK SERIES MODEL B32 4 AND 6 FOOT CONTOUR SURFACE MOUNT BENCH WITH 3" x 4" LUMBER TIMBERS**

DATE **06-07-21**

DWG. NO. **AI-1500**