

# MODEL B-24 PREMIER PARK GRILL



*Model B-24 B2 Grill with Optional Utility Side Shelf*

- **Infinitely adjustable cooking grate**
- **Structurally reinforced grate is virtually indestructible**
- **Grate tips back for fire building and cleaning**
- **Integral ash retainer flange prevents ashes from falling from the firebox and combats heat warpage along with die-formed back flange and side panel flares**
- **Firebox bottom is ring-reinforced against heat warpage**
- **Theft-proof base attachment**
- **Full 360° rotation for draft control**
- **Public use-type spring grips of coiled steel bar**
- **Utility shelf option**
- **Quality construction throughout**

## AVAILABLE OPTIONS

- Side Utility Shelf
- Portable Disk Base
- Bolt-down Base Plate Base
- Caster Base
- S6 Swivel Shelf

## SPECIFICATIONS:

- **Model B-24 B2** has a cooking area of 384 sq. in. with one grate and a 16" x 24" firebox with 8" high sides.
- Entire firebox is fabricated from 3/16" steel plate. All exposed corners are rounded to 1-1/2" radius and all edge connections are entirely welded. Firebox has an integral ash retainer die-formed across the front of the box. Firebox has a reinforcing flange die-formed into the back panel and reinforcing flares die-formed into side panels. Firebox is ring reinforced and allowance for drainage is provided.
- Grate is infinitely adjustable from 3-3/4" to 12" above the bottom of the firebox. Grate tips back to provide unobstructed access to the firebox for cleaning and fire building.
- Grate is structurally reinforced to support the weight of two or more persons without sagging or bending.
- Grate is secured to firebox by 2 vertical 3/4" dia. A-36 steel bars that allow adjustment and prevent removal of the grate from the grill.
- Grate is constructed from 5/8" dia. A-36 steel bars around the perimeter and handles and 1/2" dia. A-36 steel bars to provide the grate surface.
- Grate is provided with two substantial spring grip handles suitable for use by the public made from 1/8" x 1/2" steel flat bar.
- A base attachment mechanism constructed from 3/16" steel plate is provided that is absolutely theft-proof, allows unrestrained continuous rotation in either direction, and maintains a stable cooking surface.
- **Standard:** Grill is supported by a 3-1/2" O.D., 40" long, steel pipe for permanent installation in concrete footing (indicated by B2 in model no., e.g. B-24 B2).
- Entire unit is finished in high temperature, heat resistant, nontoxic black enamel.
- **Optional:** Grill is provided with a 3/16" x 7-1/8" x 9-5/8" steel plate utility shelf. Add /S to model no., e.g. B-24/S B2.
- **Optional:** Grill shall be provided with a bolt-down base plate base for hard surface mounting applications. Replace "B2" in model no. with "B3", e.g. B-24 B3.
- **Optional:** Grill shall be provided with a portable disc base. Replace "B2" in model no. with "B4", e.g. B-24 B4.
- **Optional:** Grill shall be provided with a portable caster base. Replace "B2" in model no. with "B14", e.g. B-24 B14.
- **Optional: Model S6** 8" x 16" swivel shelf is available as an additional item. Shelf must be installed on base post before grill.

**RJ Thomas Mfg. Co., Inc.**

PO Box 946 • Cherokee, IA 51012-0946 • PH: 712-225-5115 • 800-762-5002 • FAX: 712-225-5796  
E-mail: pilotrock@rjthomas.com • Web Site: <http://www.pilotrock.com>

© 2012 RJ Thomas Mfg. Co., Inc. PILOT ROCK® Park Products is a registered trademark of RJ Thomas Mfg. Co., Inc.

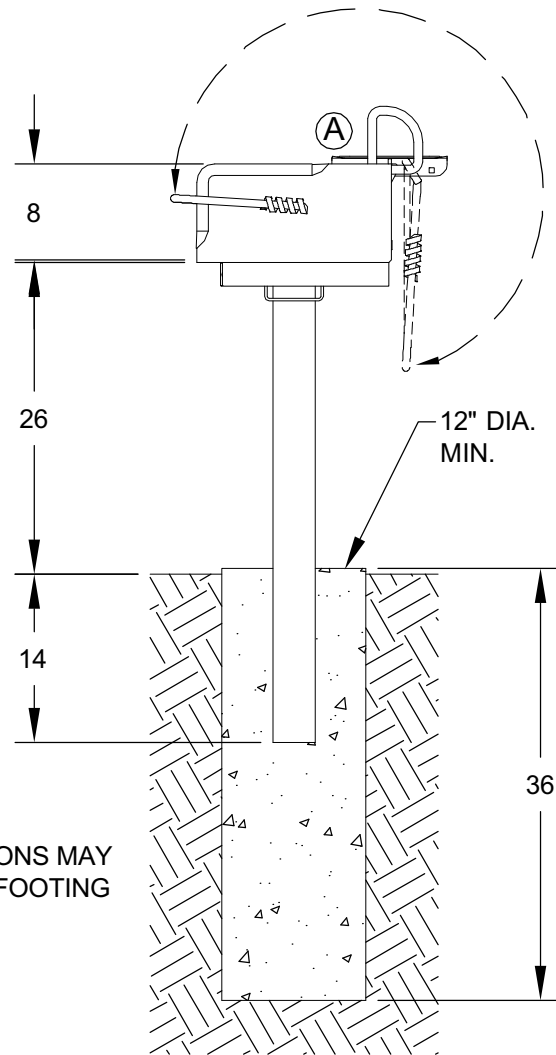
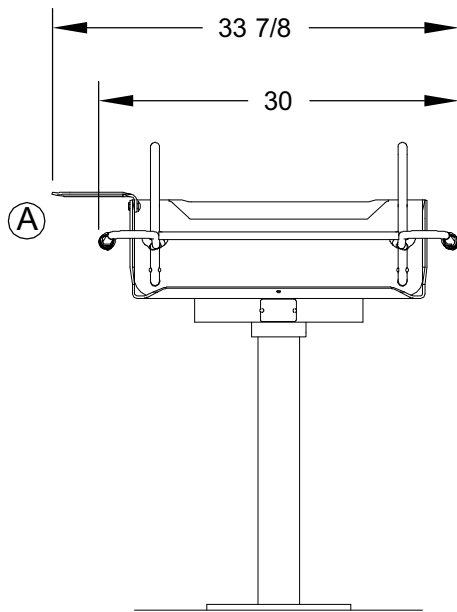
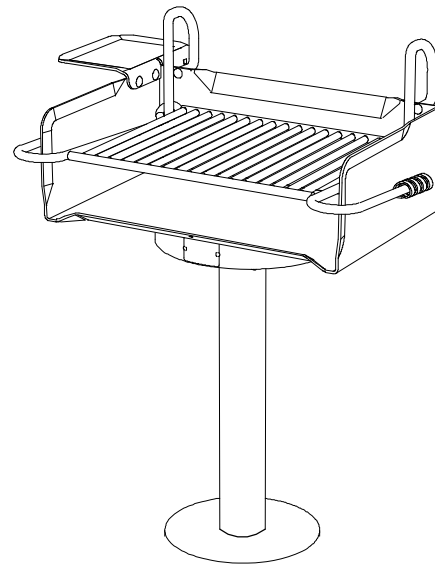
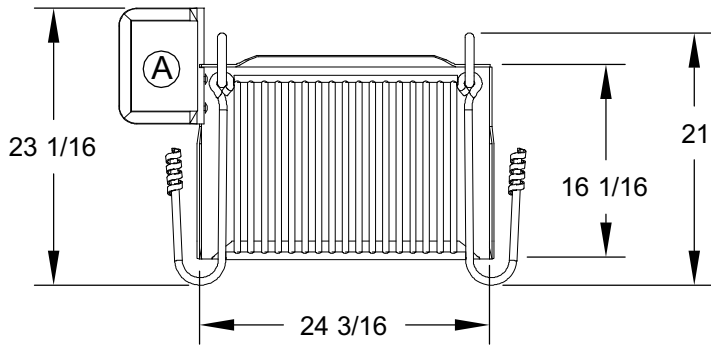

Ⓐ OPTIONAL UTILITY SHELF - ADD /S TO MODEL NUMBER

NOTE:  
LOCAL SOIL CONDITIONS MAY  
REQUIRE A LARGER FOOTING

ALL DIMENSIONS IN INCHES

**RJThomas**  
**Mfg. Co., Inc.**  
P.O. Box 946  
Cherokee, IA 51012

TITLE **B-24 PARK GRILL SHOWN WITH B2 BASE  
& OPTIONAL UTILITY SHELF**

DRAWN BY	<b>WWM</b>
DATE	<b>10-12-08</b>
DWG. NO.	<b>AI-1005</b>