

BTU Series 4, 6, and 8 Foot Bolt Together Portable Rectangular Table with Lumber Top and Seats



Model BTUG-4UP 4' Bolt Together Portable Rectangular Table with Pregalvanized Frame and Untreated Southern Yellow Pine Planks

- **Economy of bolt together design**
- **Strong 1-5/8" diameter steel tubing construction**
- **Walk though, nontrip, nontip design**
- **Choice of treated or untreated lumber**
- **Pregalvanized frame components for maintenance-free performance**
- **Diagonal bracing for strength and rigidity**
- **Simple bolt together assembly with all fasteners included**

SPECIFICATIONS:

- **BTUG Series** end frames are fabricated from 1.660" O.D. (1-5/8" O.D.) pregalvanized steel tubing.
- Table frame design incorporates nontip, nontrip, walk-through design features.
- **Model BTUG-4UP** is a nom. 4 ft. long.
- **Model BTUG-6UP** is a nom. 6 ft. long.
- **Model BTUG-8UP** is a nom. 8 ft. long.
- Table top is attached to and supported by 10 ga x 1-3/8" x 2" formed pregalvanized steel angle. Seats are attached to and supported by 10 ga x 1-3/4" x 6-1/4" formed pregalvanized steel angle.
- Nominal table height is 28". Nominal seat height is 17".
- Frames are supported by diagonal braces of 1-5/16" O.D. pregalvanized steel pipe.
- All galvanized fasteners are provided for assembly.
- **Standard:** Lumber is Untreated #1 grade Southern Yellow Pine (denoted by "UP" in model no., e.g. BTUG-6UP) 2" x 10" nominal sized planks, kiln dried to reduce moisture content. All lumber is precision drilled to facilitate assembly and has all exposed edges removed to a 3/8" radius.
- **Optional:** Treated #1 Southern Yellow Pine is readily available and is pressure treated and kiln dried after treatment (KDAT) to preserve wood against decay. To specify, change "UP" in model no. to "TP", e.g. BTUG-6TP.

AVAILABLE OPTIONS

4', 6', or 8' length
Treated lumber

RJ Thomas Mfg. Co., Inc.

PO Box 946 • Cherokee, IA 51012-0946 • PH: 712-225-5115 • 800-762-5002 • FAX: 712-225-5796
E-mail: pilotrock@rjthomas.com • Web Site: <https://www.pilotrock.com>

© 2020 RJ Thomas Mfg. Co., Inc. PILOT ROCK® Park Products is a registered trademark of RJ Thomas Mfg. Co., Inc.

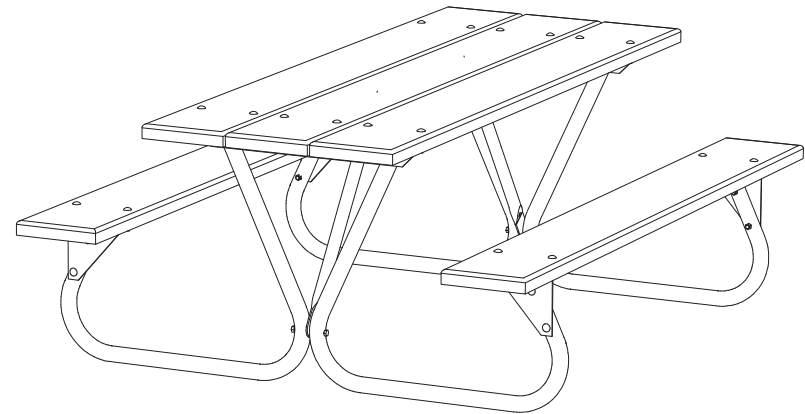
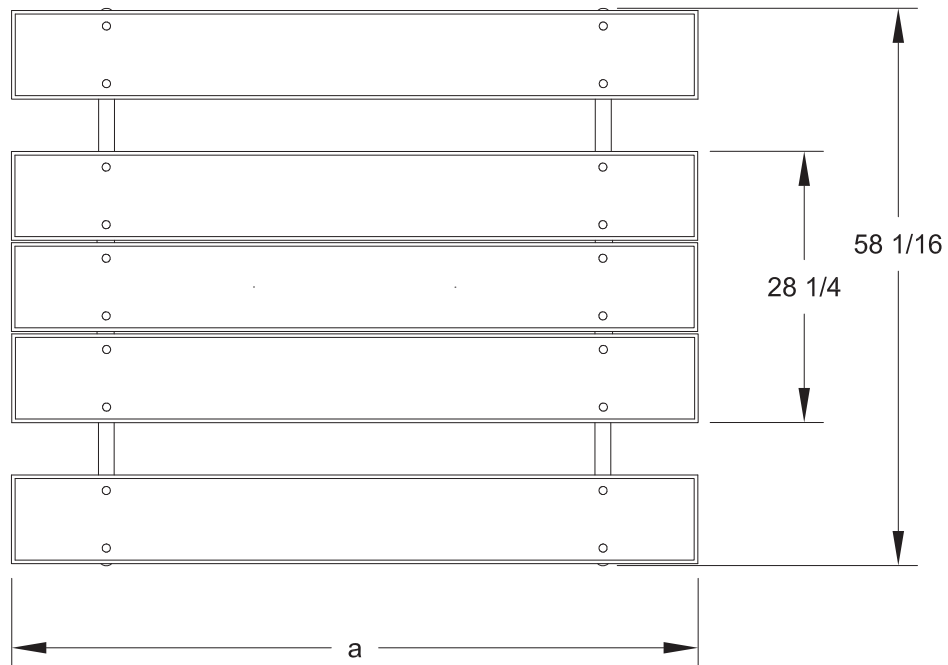

MODEL NUMBER	DIMENSION	
	a	b
BTUG-4	47-1/2	30-1/16
BTUG-6	71-1/2	51-7/8
BTUG-8	95-1/2	70

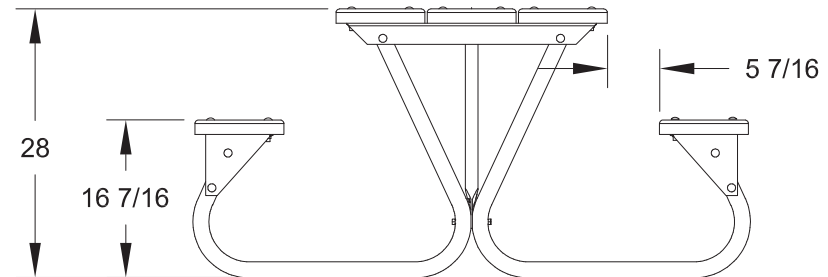
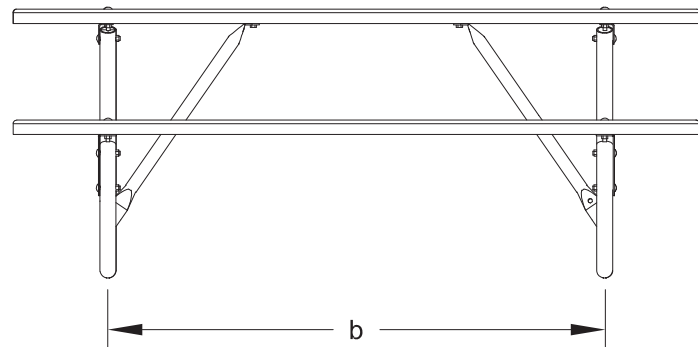

ALL DIMENSIONS IN INCHES

R. J. **THOMAS MFG. Co., Inc.**
P.O. Box 946 • Cherokee, IA 51012

DRAWN BY
WWM

TITLE MODEL BTUG SERIES 4, 6, AND 8 FOOT BOLT-TOGETHER PORTABLE
RECTANGULAR TABLE WITH 2" X 10" LUMBER TOP AND SEAT PLANKS

DATE 4-18-05

DWG. NO. **AI-1650**