



*Model BTXG-6AL 6' Bolt Together Portable
Rectangular Table with Pregalvanized Frame
and Clear Anodized Aluminum Top and Seats*

- **Economy of bolt together design**
- **Strong 2-3/8" diameter steel tubing construction**
- **Walk though, nontrip, nontip design**
- **Structurally reinforced extruded Aluminum Top and Seats with clear anodized finish**
- **Pregalvanized frame components for maintenance-free performance**
- **Diagonal bracing for strength and rigidity**
- **Simple bolt together assembly with all fasteners included**

SPECIFICATIONS:

- **BTXG Series** end frames are fabricated from 2.375" O.D. (2-3/8" O.D.) 12 ga. wall pregalvanized steel tubing.
- Table frame incorporates nontip, nontrip, walk-through design features.
- **Model BTXG-6** is a nom. 6 ft. long.
- **Model BTXG-8** is a nom. 8 ft. long.
- Table top is attached to and supported by 10 ga x 1-3/8" x 2" formed pregalvanized steel angle. Seats are attached to and supported by 10 ga x 1-3/4" x 6-1/4" formed pregalvanized steel angle.
- Nominal table height is 30". Nominal seat height is 18".
- Frames are supported by diagonal braces of 1-5/16" O.D. pregalvanized steel pipe.
- All fasteners are provided for assembly.
- Aluminum is extruded 6063-T6 aluminum alloy in planks with dimensions equivalent to that of 2" x 10" nominal sized lumber. The plank design is 1-3/4" x 9-5/8" with four structural reinforcement ribs for greater rigidity. Aluminum planks are provided with a clear anodized finish as per anodizing specification 204 R1. Aluminum clips to fasten planks to frames are included.
- Channel end caps are of extruded 6063-T6 aluminum alloy provided with a clear anodized finish as per anodizing specification 204 R1. End caps are press fitted over ends of aluminum planks and mechanically fastened in place at the factory.
- Table top is assembled into single unit at the factory with one-piece end caps across each end.
- **Optional:** Aluminum top and seats have powder coat finish. See Specification Bulletin #SPC-CO-001.

AVAILABLE OPTIONS

- **6' or 8' length**
- **Powder Coat Finish in choice of colors on Aluminum top and seats**

RJThomas Mfg. Co., Inc.

PO Box 946 • Cherokee, IA 51012-0946 • PH: 712-225-5115 • 800-762-5002 • FAX: 712-225-5796
E-mail: pilotrock@rjthomas.com • Web Site: <http://www.pilotrock.com>

© 2008 RJThomas Mfg. Co., Inc. PILOT ROCK® Park Products is a registered trademark of RJThomas Mfg. Co., Inc.

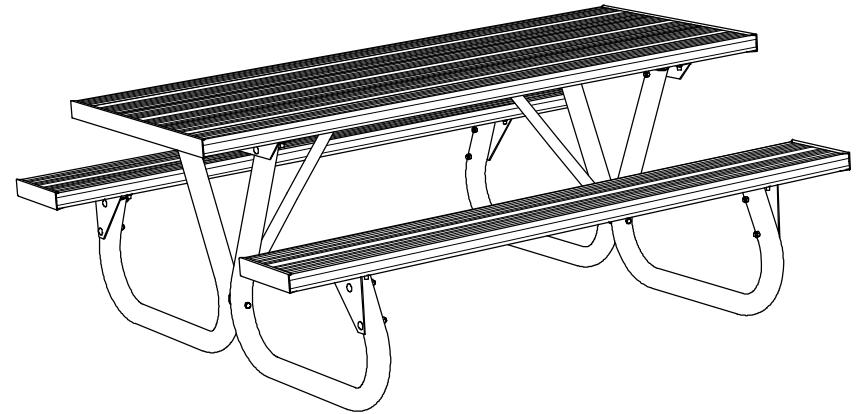
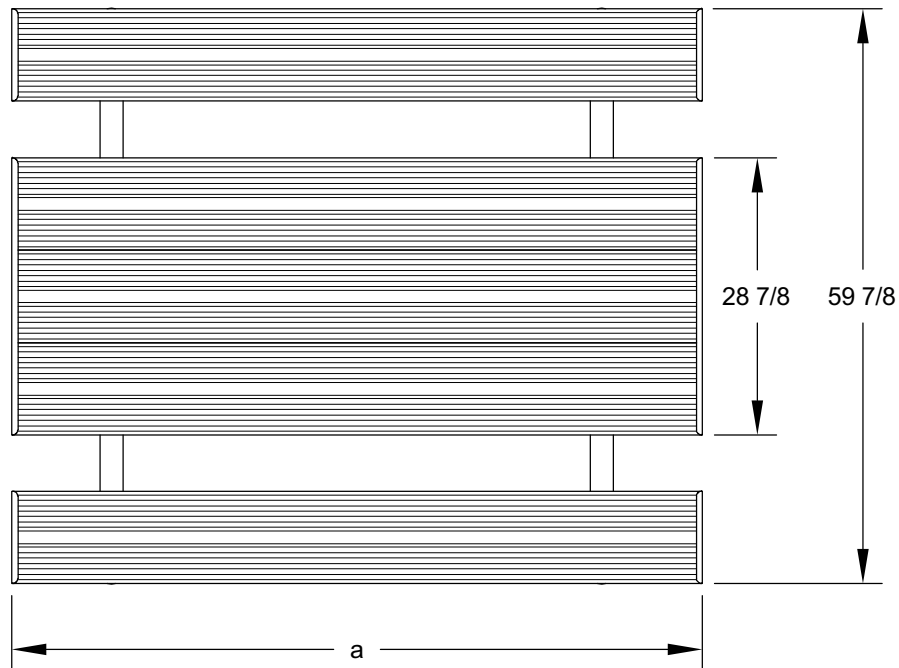

MODEL	DIMENSION	
	a	b
BTX-6	72	51 5/8
BTX-8	96	69 3/8

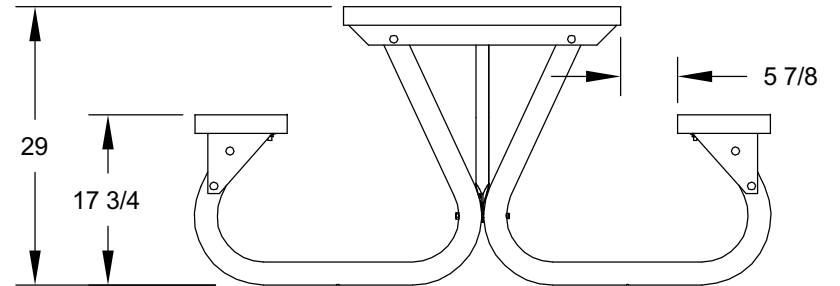
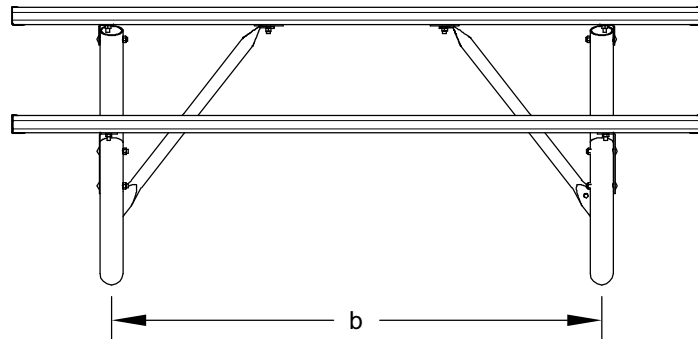

ALL DIMENSIONS IN INCHES

RJThomas Mfg. Co., Inc.
P.O. Box 946 • Cherokee, IA 51012-0946

DRAWN BY
WWM

TITLE BTXG SERIES 6 AND 8 FOOT BOLT-TOGETHER RECTANGULAR TABLE WITH
ALUMINUM TOP AND SEATS

DATE 6-12-09

DWG. NO. AI-1909