



*Model BTXG-6UP 6' Heavy Duty Bolt Together Portable  
Rectangular Table with Pregalvanized Frame  
and Untreated Southern Yellow Pine Planks*

- **Economy of bolt together design**
- **Strong 2-3/8" diameter steel tubing construction**
- **Walk though, nontrip, nontip design**
- **Choice of treated or untreated lumber**
- **Pregalvanized frame components for maintenance-free performance**
- **Diagonal bracing for strength and rigidity**
- **Simple bolt together assembly with all fasteners included**

**SPECIFICATIONS:**

- **BTXG Series** end frames are fabricated from 2.375" O.D. (2-3/8" O.D.) pregalvanized steel tubing.
- Table frame incorporates nontip, nontrip, walk-through design features.
- **Model BTXG-6UP** is a nom. 6 ft. long.
- **Model BTXG-8UP** is a nom. 8 ft. long.
- Table top is attached to and supported by 10 ga x 1-3/8" x 2" formed pregalvanized steel angle. Seats are attached to and supported by 10 ga x 1-3/4" x 6-1/4" formed pregalvanized steel angle.
- Nominal table height is 30". Nominal seat height is 18".
- Frames are supported by diagonal braces of 1-5/16" O.D. pregalvanized steel pipe.
- All galvanized fasteners are provided for assembly.
- **Standard:** Lumber is Untreated #1 grade Southern Yellow Pine (denoted by "UP" in model no., e.g. BTXG-6 UP) 2" x 10" nominal sized planks, kiln dried to reduce moisture content. All lumber is precision drilled to facilitate assembly and has all exposed edges removed to a 3/8" radius.
- **Optional:** Treated #1 Southern Yellow Pine is readily available and shall be pressure treated and kiln dried after treatment (KDAT) to preserve wood against decay (to specify, change "UP" in model no. to "TP", e.g. BTXG-6 TP).

**AVAILABLE OPTIONS**

6' or 8' length  
Treated lumber

**RJThomas Mfg. Co., Inc.**

PO Box 946 • Cherokee, IA 51012-0946 • PH: 712-225-5115 • 800-762-5002 • FAX: 712-225-5796  
E-mail: pilotrock@rjthomas.com • Web Site: <http://www.pilotrock.com>

© 2008 RJThomas Mfg. Co., Inc. PILOT ROCK® Park Products is a registered trademark of RJThomas Mfg. Co., Inc.

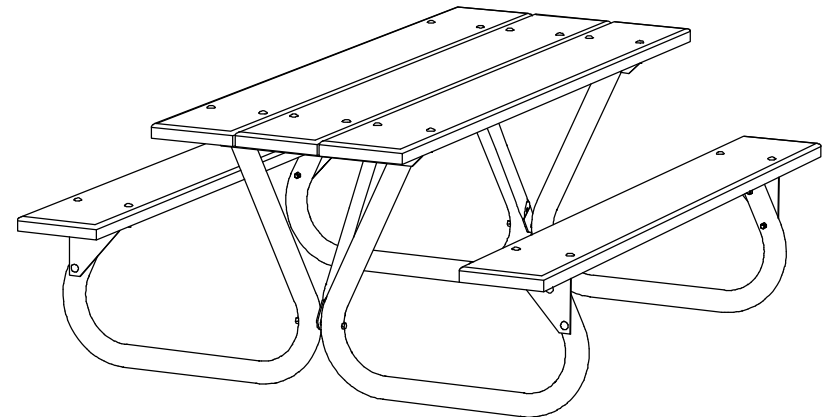
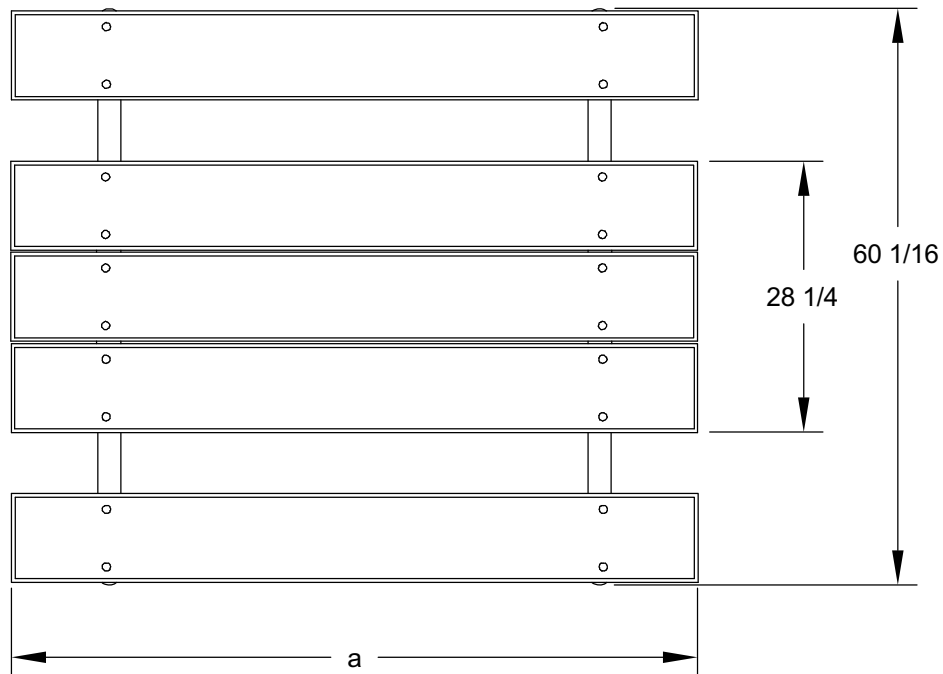

MODEL NUMBER	DIMENSION	
	a	b
BTXG-6	71-1/2	51-3/4
BTXG-8	95-1/2	70

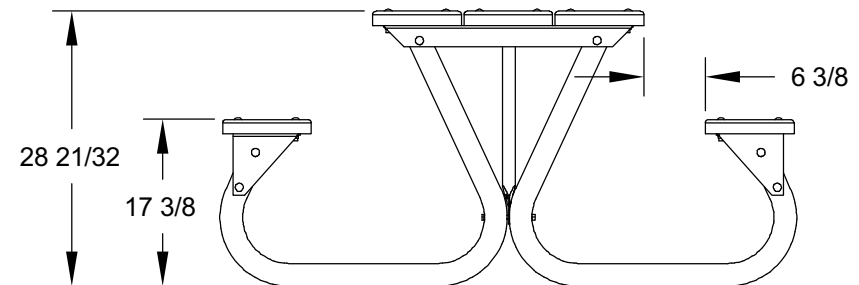
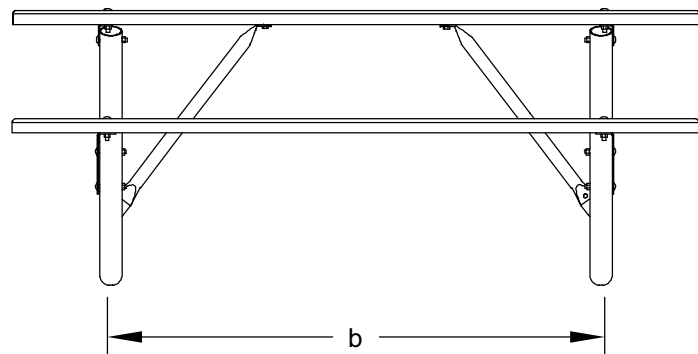

ALL DIMENSIONS IN INCHES

**RJThomas Mfg. Co., Inc.**  
P.O. Box 946 • Cherokee, IA 51012-0946

DRAWN BY  
**WWM**

TITLE MODEL BTXG SERIES 6 AND 8 FOOT BOLT-TOGETHER PORTABLE RECTANGULAR  
TABLE WITH 2" X 10" LUMBER TOP AND SEAT PLANKS

DATE 10-31-08

DWG. NO. AI-1651